

Edition Date: 20250319

Edition Item: 800MT(6WW5-00WX01-6000)SM-20250319

This manual is intended for use by experienced technicians in a fully equipped workshop and is intended primarily for reference. All references to left and right are made from the perspective of the driver while seated in the driving position.

Certain procedures outlined in this manual require a sound knowledge of mechanical or electrical theory, tool use and shop procedures in order to perform the work safely and correctly. Technicians should read the contents of this manual and understand the procedures before beginning repairs. Certain procedures require the use of specialized tools. Use only the proper tools specified. If you have any questions about your ability to perform any of the procedures outlined in this manual, contact an authorized dealer for service.

The information in this manual includes the most current product information available at the time of publishing and may contain product information that does not apply to your particular market. The instructions contained in this publication are not legally binding. CFMOTO reserves the right to modify or completely delete technical instructions, service instructions, maintenance instructions, prices, colors, shapes, materials, designs, configurations and similar content without prior notice and without reason. Due to continuous improvements in the design and quality of production components, minor discrepancies may result between the actual vehicle and the information provided within. No liability can be accepted for omissions, deviations, inaccuracies, printing defects or errors in the delivery method, drawings and instructions. Any reproduction or reuse of the images, descriptions and/or procedures within, whether whole or in part, is expressly prohibited without written permission from the copyright holder.

© CFMOTO Powersports, Inc. This manual is subject to all applicable copyright laws. Reproduction or duplication in any form, whole or in part, is strictly prohibited.

# **CFMOTO**

## **IBEX 800 S**

## **IBEX 800 T**

## **IBEX 800 E**

# **SERVICE**

# **MANUAL**

Website: [www.cfmoto.com](http://www.cfmoto.com)

## INTRODUCTION

This manual introduces CF800-5 CF800-5A CF800-5US CF800-5AUS CF800-5BUS maintenance information, including disassembly procedure checking & adjustment methods, troubleshooting and technical specifications. There are some illustrations, drawing to guide your operation.

The first three chapters mainly introduce general operation information, special tool, vehicle structure, basic specification, inspection & maintenance methods etc.,

The rest chapters introduce vehicle part removal, installation, adjustment, service, fault diagnosis and etc.,

CFMOTO has the copyright and final interpretation of this manual. Do not copy, translation without CFMOTO permit. Any transmission or recording is prohibited.

This manual has been improved by using many ways to make it accuracy. But we are no response for any difference and missing.

CFMOTO reserves right to make improvements and modifications to the products without prior notice. Overhaul and maintenance should be done according to actual condition of vehicle. And CFMOTO is not responsible for production improvements and modifications. This manual is only for reference. If any objections, please ask the nearest dealer to get the latest information.

The information in this manual are the latest depends on latest productions on coming out. The images in this manual may not stand for real model assy and parts.

**CFMOTO reserves right to make improvements and modifications to the products without prior notice. Overhaul and maintenance should be done according to actual condition of vehicle.**

CFMOTO CO.LTD

## INDEX

General Information	1
Maintenance Information	2
Technical Information	3
Seat	4
Body Covering Parts	5
Fuel System	6
Lights, Dashboard and Switches	7
Electrical System	8
Cooling System	9
Muffler Assy	10
Wheels and Brake System	11
Shock Absorbers and Rear Fork	12
Engine	13
Handlebar and Triple Clamps	14

**NOTE: Wire diagram is posted separately on the dealer portal.**

### Conversion table

<b>A</b>	Ampere	<b>lb</b>	Pound
<b>ABDC</b>	After bottom dead center	<b>m</b>	Meter
<b>AC</b>	Alternating current	<b>min</b>	Minute
<b>ATDC</b>	After top dead center	<b>N</b>	Newton
<b>BBDC</b>	Before bottom dead center	<b>Pa</b>	Pascal
<b>BDC</b>	Bottom dead center	<b>PS</b>	Metric horse power
<b>BTDC</b>	BTDC Before top dead center	<b>Psi</b>	Pound/Square Inch
<b>°C</b>	Centigrade	<b>r</b>	Revolutions
<b>DC</b>	Direct current	<b>rpm</b>	Revolutions per minute
<b>F</b>	Farad	<b>TDC</b>	Top dead center
<b>°F</b>	Fahrenheit	<b>TIR</b>	Total indicator reading
<b>ft</b>	Feet	<b>V</b>	Volt
<b>g</b>	Gram	<b>W</b>	Watt
<b>h</b>	Hour	<b>Ω</b>	Ohm
<b>L</b>	Litre	<b>in</b>	Inch
<b>US gal</b>	Gallon(US)	<b>US qt</b>	Quart(US)
<b>oz</b>	Ounce	<b>HP</b>	British horsepower
<b>cm Hg</b>	Centimeter of mercury	<b>pint</b>	Pint
<b>cu in</b>	Cubic inch	<b>mL</b>	Milliliter

## Forward

This service manual is not only specially designed for professional machinist, but also it is used to instruct the vehicle's user how to do maintenance work. It is necessary to know mechanical knowledge, tools proper usage and have a well understanding of service procedure Conversion before you perfectly solve all service problems. If no, you should get the service support by professional machinist. Please read this service manual and understand it before operate for high efficiency work. And working in clean area. For vehicle mechanical performance and safety works. No tools replaced or use temporary tools since that we have been appointed the special service tools and equipment. All service and scheduled maintenance should be executed base on the instructions of service manual. Any consequences are responsible by the vehicle's owner resulted from any rule-breaking operations.

### How to get Long Service Life:

- Follow scheduled maintenance and service operations base on service manual.
- Non-periodical maintenance in special situations.
- Use tools properly and use CFMOTO genuine parts.
- Special tools, dashboard and tester have been listed into this service manual for necessary genuine parts.
- Strictly operated bas on the correct service procedures.
- Keep fully service records and specify the date of new parts replacement.

### How to use this manual:

In this manual, the production will be separated as several systems. All the systems are shows up in the contents. That will help you to lock the chapter. And each chapter has its own contents. For example, If you wanna see ignition coil information, use the contents to find our the electrical system and find the ignition coil in electrical system chapter.

Whenever you see the warning or warning symbol, you must keep attention and comply with the safety operation and maintenance method

 **DANGER:** This symbol means it will cause serious injuries even death if you don't follow the procedure.

 **WARNING:** This symbol means the special steps. It may cause the vehicle damage if you don't follow the procedure.

 **CAUTION:** This symbol means the special steps for higher efficiency and easier working.

**NOTE:** It makes operation process easier or offers clearer information. It has no symbol.

**NOTE:**  
The vehicle removal procedures are not included electrical parts, police implements and engine. Electrical parts and engine are shown in the separate chapters.  
All connectors are unplugged by default during removal.  
The guide line without serial number in the picture indicates the direction of removal.

# 01 General Information

---

- 1.1 Operation Cautions .....2
- 1.2 Disassembly and Assembly Cautions .....4
- 1.3 VIN and EIN Location .....8
- 1.4 Electrical Parts Routing .....8
- 1.5 Fuel Evaporation System Diagram .....9

© CFMOTO Powersports, Inc. This manual is subject to all applicable copyright laws. Reproduction or duplication in any form, whole or in part, is strictly prohibited.

# CFMOTO

## 1.1 Operation Cautions

**⚠ DANGER:** Hazardous components in exhaust. Do not run the engine in an enclosed or poor ventilated place for a long time.



**⚠ WARNING:** Don't touch the engine or muffler with bare hands when the engine has just stopped to avoid hurt. Wear long-sleeve work clothes.



**⚠ WARNING:** Battery liquid (dilute sulfuric acid) is highly caustic and may cause burns to skin and eyes. Flush with water if splashed to skin and get immediate medical attention. Flush with water if splashed to clothes to avoid burns. Keep battery and liquid away from reach of children.



**⚠ WARNING:** Coolant is poisonous. Do not drink or splash to skin, eyes or clothes. Flush with plenty of soap water if splashed to skin. Flush with water and consult doctors. If drinking the coolant, induce vomiting and consult doctors. Keep coolant away from reach of children.

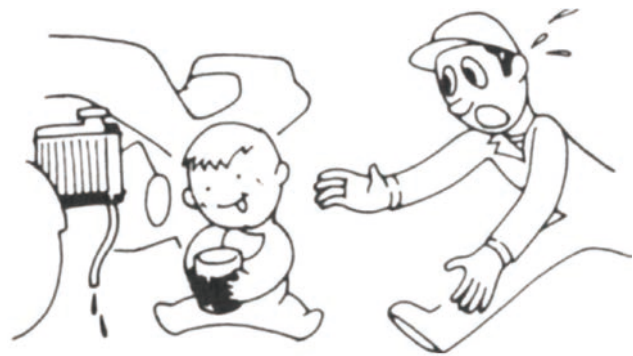

© CFMOTO Powersports, Inc. This manual is subject to all applicable copyright laws. Reproduction or duplication in any form, whole or in part, is strictly prohibited.

# 01 General Information

**⚠ WARNING:** Wear proper work clothes, cap and boots. Wear dust-glass, gloves and mask if necessary.



**⚠ DANGER:** Coolant Gasoline is highly flammable. No smoking or fire. Also keep against sparks. Vaporized gasoline is also explosive. Operate in a well-ventilated place.



**⚠ DANGER:** When charged, Battery may generate hydrogen which is explosive. Charge the battery in a well-ventilated place.



**⚠ WARNING:** The asbestos dust on the brake drum is carcinogenic. Do not clean off the dust with compressed air. Use cleaning detergent to avoid dust proliferation.



**⚠ DANGER:** Be careful to get clamped by the turning parts like wheels and clutch.



© CFMOTO Powersports, Inc. This manual is subject to all applicable copyright laws. Reproduction or duplication in any form, whole or in part, is strictly prohibited.

## 1.2 Disassembly and Assembly Cautions

■ Use genuine CFMOTO Parts, lubricants and grease.

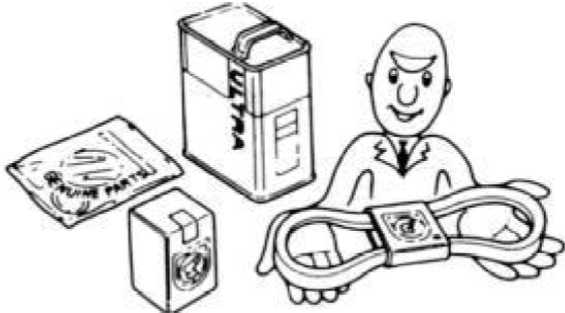

■ Place and store the disassembled parts separately in order for correct assemble.

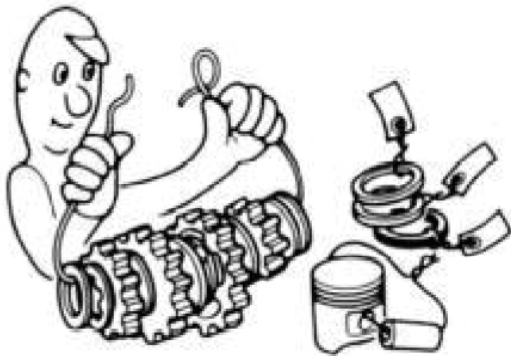

■ Clean and blow off the detergent after disassembling the parts. Apply lubricants on the surface of moving parts.

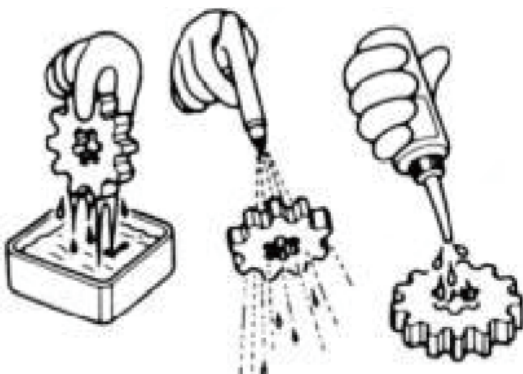

■ Clean the mud, dust before overhauling.



■ Replace the disassembled washers, O-rings, piston pin circlip and cotter pin with new ones.

■ Elastic circlips might get distorted after disassembled. Do not use the loosed circlips.



■ Measure the data during disassembly for correct assembly.



# 01 General Information

■ If not know the length of screws, install the screws one by one and tighten with same torque.

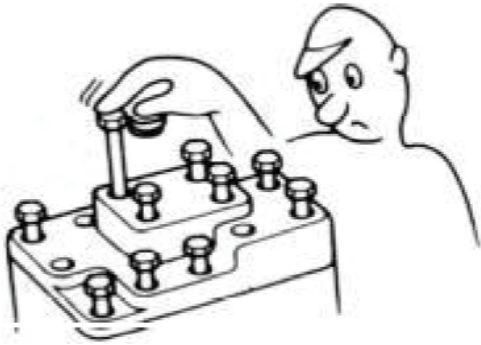

■ Pre-tighten the bolts, nuts and screws, then tighten them according to the specified torque, from big to small and from inner side to outer side.

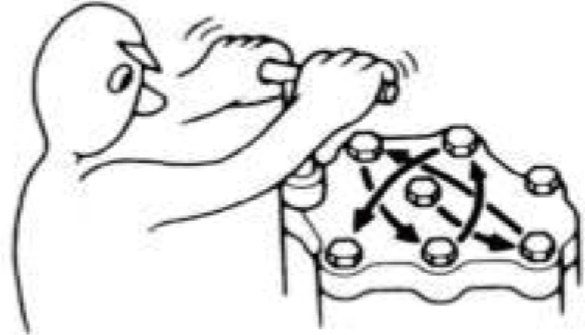

■ Check if the disassembled rubber parts are aged and replace it if necessary. Keep the rubber parts away from grease.

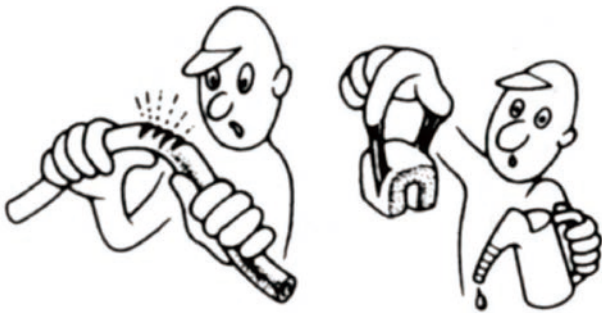

■ Apply or inject recommended lubricant to the specified parts.



■ Use special tools wherever necessary.

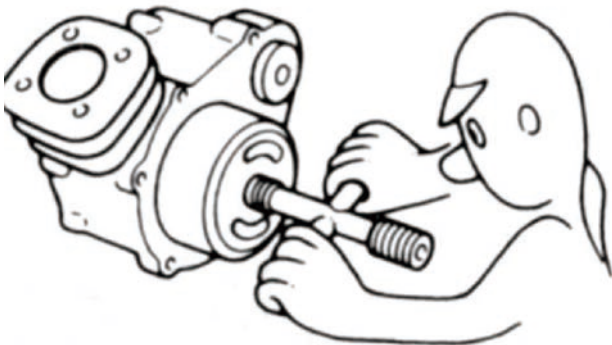

■ If the disassembling of pressed ball bearing is done by pressing the balls, the disassembled should not be used again.

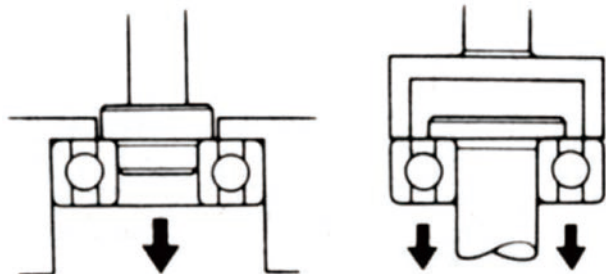

© CFMOTO Powersports, Inc. This manual is subject to all applicable copyright laws. Reproduction or duplication in any form, whole or in part, is strictly prohibited.

© CFMOTO Powersports, Inc. This manual is subject to all applicable copyright laws. Reproduction or duplication in any form, whole or in part, is strictly prohibited.

■ Turn the ball bearing with hands to make sure the bearing will turn smoothly. Replace if the axial or radial play is too big. If the surface is uneven, clean with oil and replace. If the cleaning does not help. When pressing the bearing into the machine or to the shaft, replace the bearing if it could not be pressed tight.

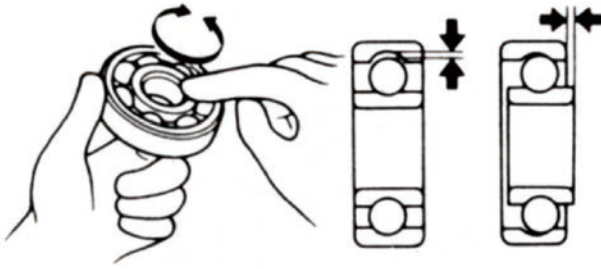

■ Keep the bearing block still when blowing dry the bearing after washing clean. Apply oil or lubricant before assembling.



■ After assembling, check if all the tightened parts are properly tightened and can move smoothly.



■ Install the one-side dust-proof bearing in the right direction. When assembling the open type or double-side dust-proof bearing, install with manufacturer's mark outward.

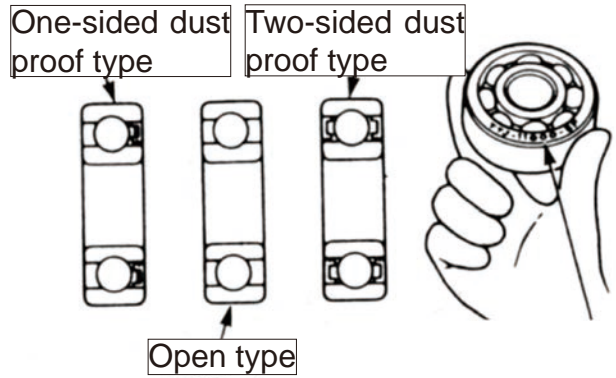

■ Install the elastic circlip after assembling to make sure it has been installed into the slot.

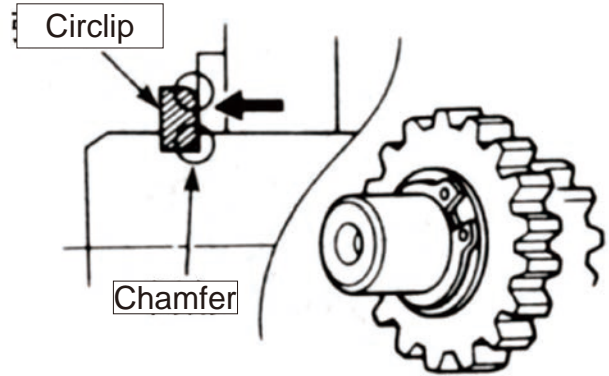

■ Brake fluid and coolant may damage coating, plastic and rubber parts. Flush these parts with water if splashed.



# 01 General Information

■ Install oil seal with the side of manufacturer's mark outward. Do not fold or scratch the oil seal lip. Apply grease to the oil seal lip before assembling.

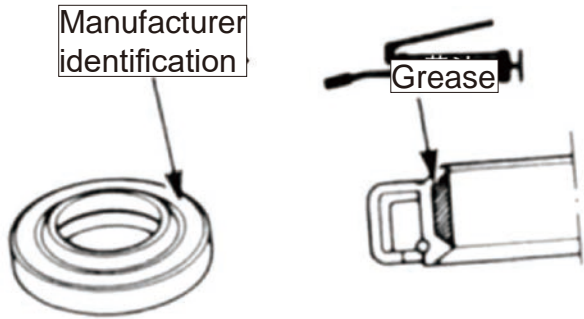

■ When installing pipes, insert the pipe till the end. Fit the pipe clip, if any, into the rove. Replace the pipes or hoses that cannot be tightened.

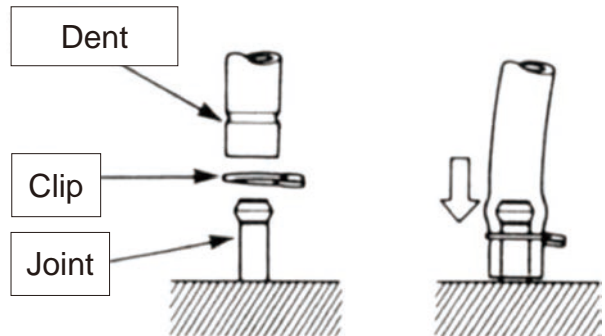

■ Do not mix mud or dust into engine or the hydraulic brake system.

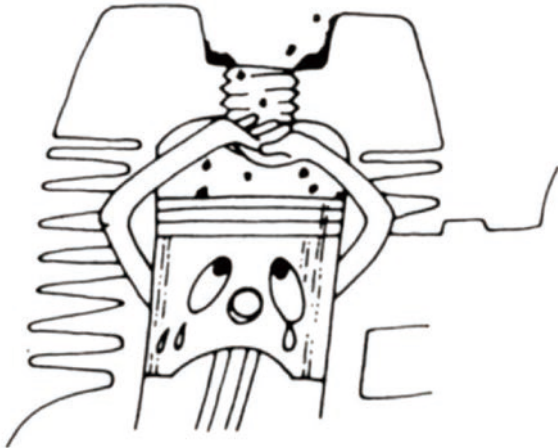

■ Clean the gaskets and washers of the engine cases before assembling. Remove the scratches on the contact surfaces by polishing evenly with an oil stone.

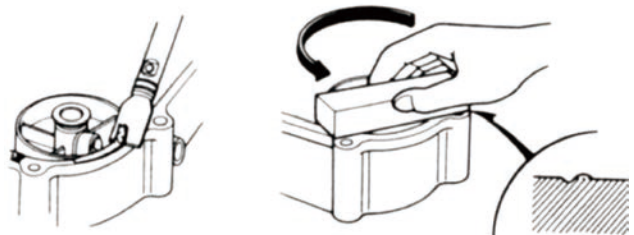

■ Do not twist or bend the cables too distorted or damaged cables may cause poor operation.

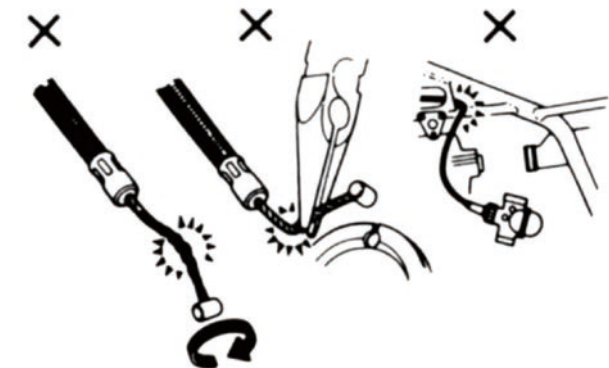

■ When assembling the parts of protection caps, insert the caps to the grooves, if any.

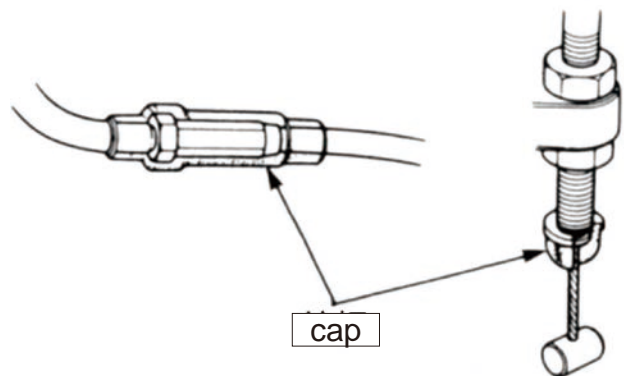

© CFMOTO Powersports, Inc. This manual is subject to all applicable copyright laws. Reproduction or duplication in any form, whole or in part, is strictly prohibited.

## 1.3 VIN and EIN Location

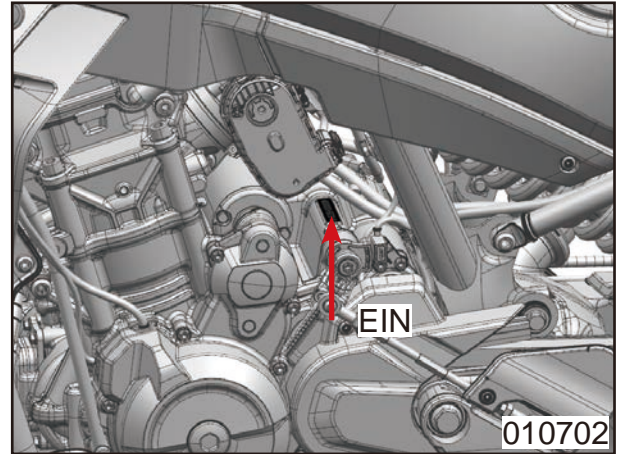
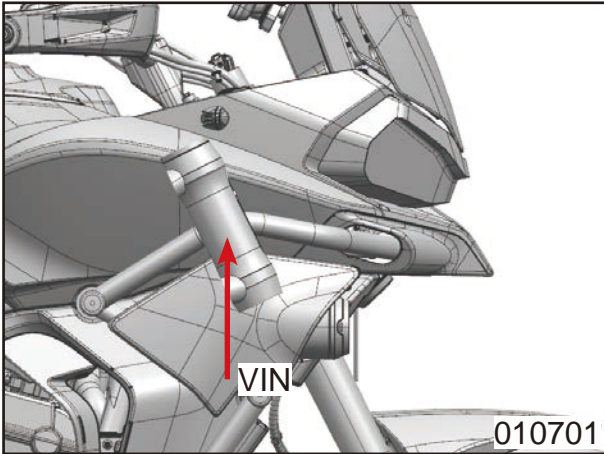

## 1.4 Electrical Parts Routing

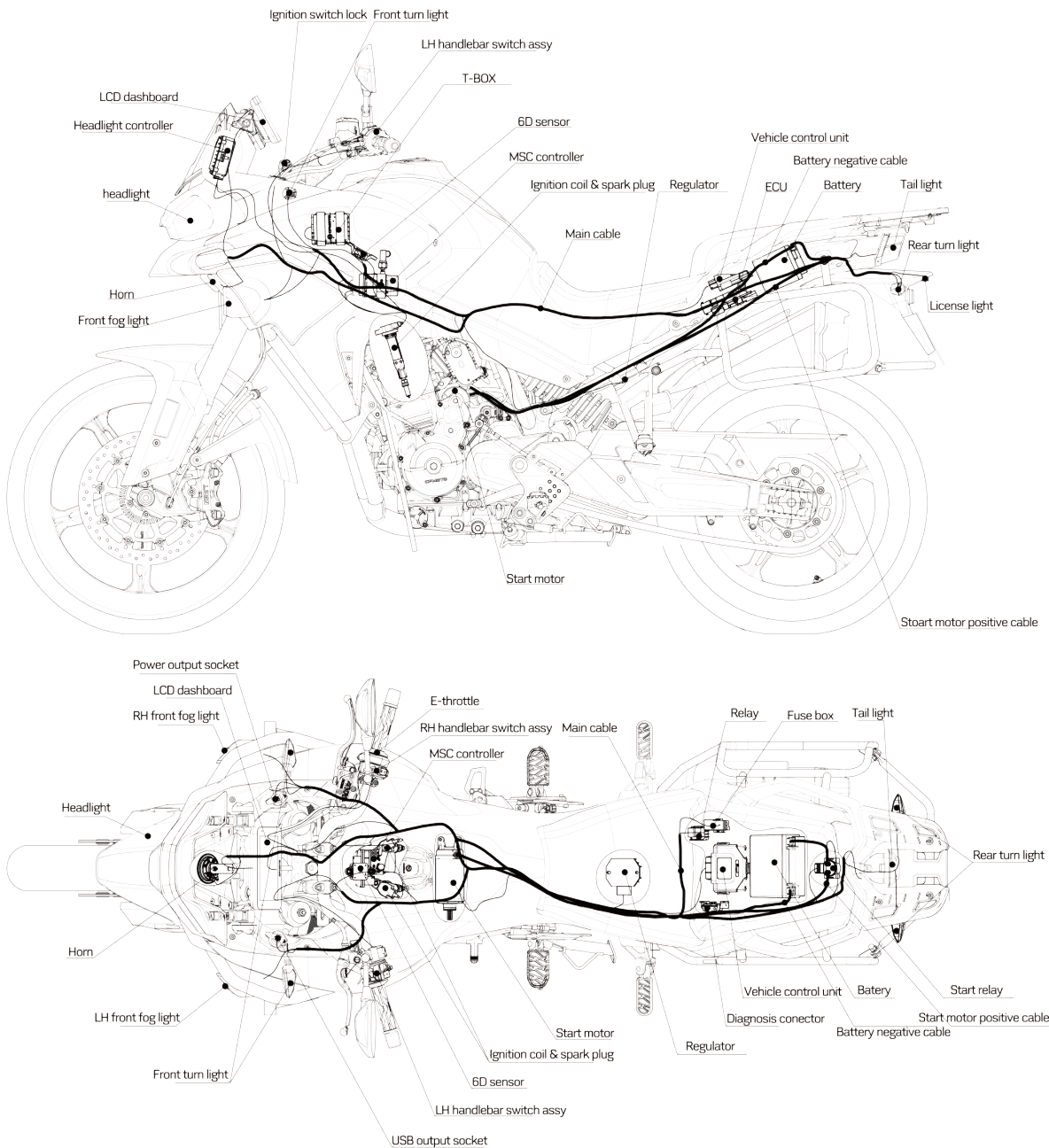

© CFMOTO Powersports, Inc. This manual is subject to all applicable copyright laws. Reproduction or duplication in any form, whole or in part, is strictly prohibited.

## 1.5 Fuel Evaporation System Diagram

**⚠ CAUTION:** To fixed the anti roll-over valve as horizontal position. Don't change the fuel evaporation system. Tube connection should be well connected after maintenance by disassembling without air leakage, blocking, squeezing, broken and damage etc. Fuel steam will be released into carbon tank by absorption tube from fuel tank. Absorbing fuel steam by active carbon when engine stop; Fuel steam of carbon tank will follow into combustor for burning when engine working in order to avoid environment pollution if fuel stem released into air directly. Meanwhile, Air pressure of fuel tank should be balanced by absorption tube. If inner pressure of fuel tank is lower than outside, it is available to replenish air pressure by air tube of carbon tank or absorption tube. So, All tube system should be smooth running without blocking and squeezing, otherwise fuel pump will be damaged, fuel tank will be deformed or broken.

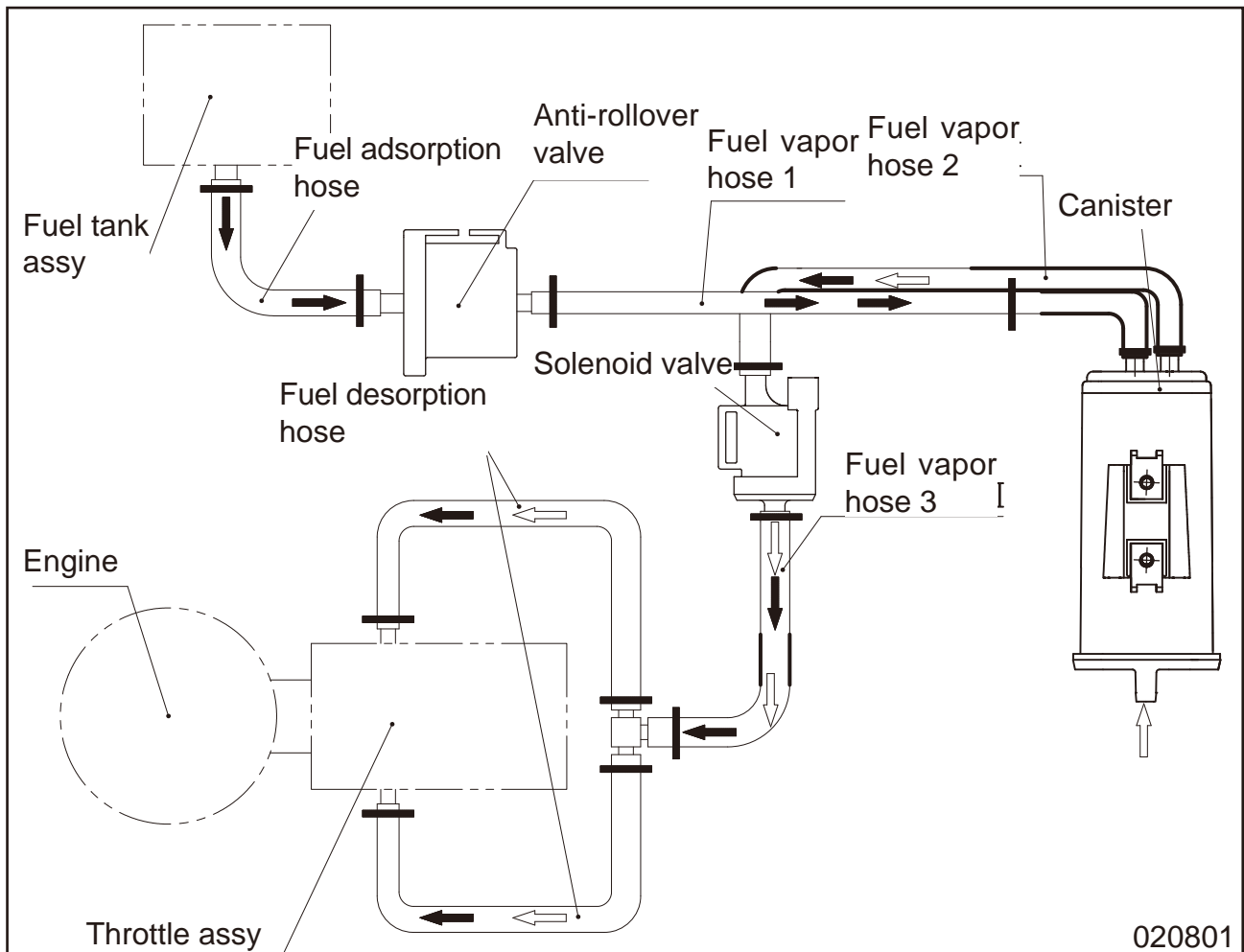

© CFMOTO Powersports, Inc. This manual is subject to all applicable copyright laws. Reproduction or duplication in any form, whole or in part, is strictly prohibited.

© CFMOTO Powersports, Inc. This manual is subject to all applicable copyright laws. Reproduction or duplication in any form, whole or in part, is strictly prohibited.

## 02 Maintenance Information

---

<b>2.1 Reset Maintenance Interval .....</b>	<b>2</b>
<b>2.1.1 TFT Dashboard .....</b>	<b>2</b>
<b>2.1.2 MMI Dashboard.....</b>	<b>2</b>
<b>2.2 Maintenance Before Operation .....</b>	<b>3</b>
<b>2.3 Break-in Maintenance Schedule .....</b>	<b>4</b>
<b>2.4 Periodic Maintenance Schedule.....</b>	<b>5</b>

© CFMOTO Powersports, Inc. This manual is subject to all applicable copyright laws. Reproduction or duplication in any form, whole or in part, is strictly prohibited.

## ⚠ CAUTION:

- ▶ = Severe Use Item. Reduce interval by 50% on vehicles subjected to severe use.
- = Have an authorized dealer perform repairs that involve this component or system.

© CFMOTO Powersports, Inc. This manual is subject to all applicable copyright laws. Reproduction or duplication in any form, whole or in part, is strictly prohibited.

## 2.1 Reset Maintenance Interval

The dashboard displays a reminder to service the vehicle when the maintenance interval mileage is reached. After regular maintenance is performed, maintenance interval information should be manually reset. The reset steps vary by dashboard type.

### 2.1.1 TFT Dashboard

On the LH handlebar switch, short press “SET” to enter the menu.

Long press “△” or “▽” to select the Information interface.

Short press “△” or “▽” to select the Service interface.

Press “SET” and “△” for more than 10 seconds to reset the maintenance interval.

Press “↵” to exit the Service interface and menu.

### 2.1.2 MMI Dashboard

Maintenance intervals are reset using DSCAN.

- Remove the rear and front seats. Chapter 4 has the details.
- Connect the DSCAN VCI to your computer and vehicle OBD port 1.

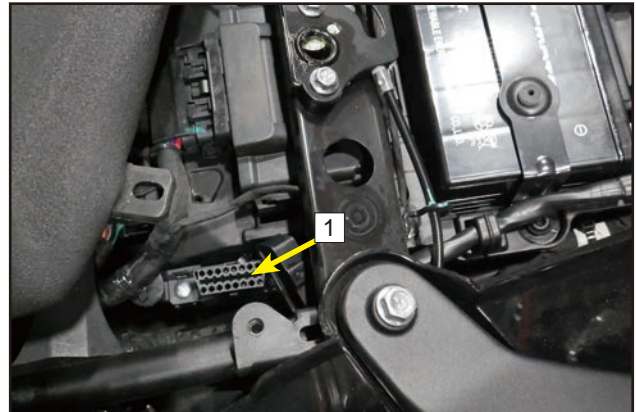

- Log into your DSCAN account.
- Confirm that the DSCAN version is V1.2.38 or newer. Update to the most recent version if needed.
- Click MODEL SELECTION in the left navigation bar.
- Select the correct motorcycle model. The screenshot shows an example.
- Click button Select.



- Double-click the icon for the Multimedia Interface System (MMI).

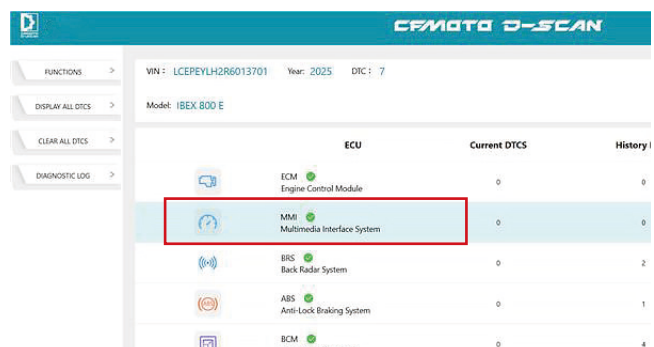

## 02 Maintenance Information

- Click WRITE DATA in the left navigation bar.
- Click the option “Vehicle maintenance mileage reset.”

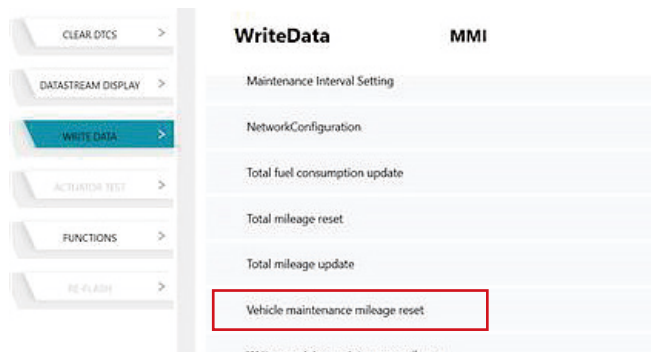

- Click button Start.



- Monitor the message stream in the Execution Process window until it shows "Routine execution ended." At this point, the maintenance interval reset is complete.
- You can exit DSCAN now.

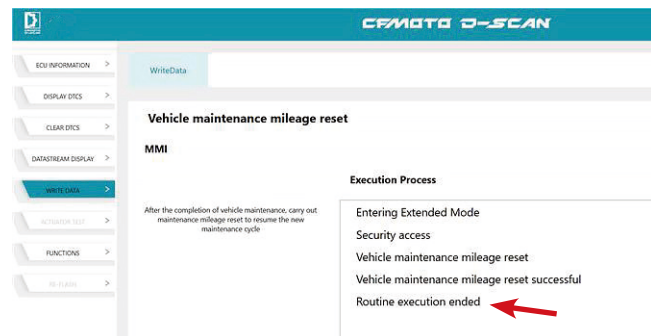

- Disconnect the DSCAN VCI from your computer and vehicle OBD port.
- Reinstall the front and rear seats. Chapter 4 has the details.

### 2.2 Maintenance Before Operation

Item	Maintenance before operation			
	Hour	Calendar	Km	Remarks
<b>Fuel system</b>				
Fuel hose	-	Daily	-	Inspect for aging
<b>Electrical system</b>				
Switches	-	Daily	-	Inspect
Lights and horns	-	Daily	-	

## 2.3 Break-in Maintenance Schedule

Item	Break-in Maintenance Interval (Service whichever interval comes first)			
	Hour	Calendar	Km	Remarks
<b>Engine</b>				
Engine oil and oil filter	-	-	1000	Replace
Oil strainer	-	-	1000	Clean
Idle	-	-	1000	Inspect
Coolant	-	-	1000	
Throttle system	-	-	1000	
<b>Electrical system</b>				
■ Functions of electrical parts	-	-	1000	Inspect
Battery	-	-	1000	
Fuses or circuit breakers	-	-	1000	
<b>Brake system</b>				
Brake discs	-	-	1000	Inspect
Brake pads	-	-	1000	
Brake fluid level	-	-	1000	
Brake lever	-	-	1000	Inspect for free play
■ Brake hoses	-	-	1000	Inspect for damage and sealing
<b>Wheels</b>				
Tire condition	-	-	1000	Inspect
Tire pressure	-	-	1000	
Rim spokes	-	-	1000	
<b>Suspension system</b>				
■ Rear shock absorber and front forks	-	-	1000	Inspect for leaking (maintain front forks and rear shock absorber according to the requirement)
<b>Cooling system</b>				
Coolant level	-	-	1000	Inspect
■ Coolant	-	-	1000	
■ Radiator fan function	-	-	1000	
Coolant hoses	-	-	1000	
<b>Steering system</b>				
■ Steering bearings	-	-	1000	Inspect
<b>Other parts</b>				
■ Diagnosis connector	-	-	1000	Read with DSCAN
■ Mobile parts	-	-	1000	Lubricate; inspect for flexibility
■ Bolts and nuts	-	-	1000	Inspect for fastness
■ Cables and wires	-	-	1000	Inspect for damage, bending and routing

## 02 Maintenance Information

### 2.4 Periodic Maintenance Schedule

Item		Periodic Maintenance Interval (Service whichever interval comes first)			
		Hour	Calendar	Km	Remarks
<b>Engine</b>					
	Engine oil and oil filter	-	12M	5000 15000	Replace
	Oil strainer	-	12M	5000 15000	
■	Clutch	-	-	15000	Inspect
	Idle	-	-	15000	
■	Coolant	-	12M	15000	Replace
		-	48M	-	
	Throttle system	-	-	10000	Inspect
■	Throttle valve	-	12M	15000	Clean
▶■	Air filter element	-	12M	15000	Replace
■	Spark plug	-	-	30000	
■	Valve clearance	-	-	30000	Inspect
<b>Electrical system</b>					
■	Functions of electrical parts	-	12M	10000	Inspect
	Battery	-	6M	5000	
	Fuses or circuit breakers	-	6M	5000	
■	Wires	-	12M	10000	Inspect for damage, bending and routing
<b>Brake system</b>					
	Front and rear brake system	-	12M	10000	Inspect
			-	24M	
	Brake discs	-	12M	10000	
			-	24M	
▶	Brake pads	-	12M	10000	
			-	24M	
	Brake fluid level	-	12M	10000	
			-	-	
■	Brake hoses	-	24M	20000	Inspect for free play
			-	12M	
	Brake lever	-	24M	20000	Inspect for damage and sealing
			-	12M	
■	Brake fluid	-	24M	-	Replace
<b>Wheels</b>					
	Tire condition	-	12M	10000	Inspect
			-	24M	
	Tire pressure	-	12M	10000	
			-	24M	
■	Wheel bearings	-	-	10000	
			-	-	

© CFMOTO Powersports, Inc. This manual is subject to all applicable copyright laws. Reproduction or duplication in any form, whole or in part, is strictly prohibited.

# CFMOTO

© CFMOTO Powersports, Inc. This manual is subject to all applicable copyright laws. Reproduction or duplication in any form, whole or in part, is strictly prohibited.

Item	Periodic Maintenance Interval (Service whichever interval comes first)			
	Hour	Calendar	Km	Remarks
<b>Suspension system</b>				
■ Suspension system	-	-	5000	Inspect
	-	-	10000	
	-	-	15000	
■ Rear shock absorber and front forks	-	12M	10000	Inspect for leaking (maintain parts according to the requirement)
	-	24M	20000	
■ Swing arms	-	-	10000	Inspect
	-	-	30000	
<b>Cooling system</b>				
Coolant level	-	12M	10000	Inspect
	-	24M	20000	
■ Coolant	-	12M	10000	
	-	24M	20000	
■ Radiator fan function	-	12M	10000	
	-	24M	20000	
■ Coolant hoses	-	12M	10000	
	-	48M	30000	
<b>Frame system</b>				
Frame	-	-	30000	Inspect
<b>Steering system</b>				
■ Steering bearings	-	12M	10000	Inspect
	-	24M	20000	
<b>Chain</b>				
▶ Chain lubrication	-	-	600	Check after riding on rainy days
Chain tightness	-	-	1000	Inspect
Chain, rear sprocket and engine sprocket wear condition	-	12M	10000	Inspect
Chain guard	-	12M	10000	Inspect
<b>Other parts</b>				
■ Diagnosis connector	-	12M	10000	Read with DSCAN
	-	24M	20000	
■ Mobile parts	-	12M	10000	Lubricate; inspect for flexibility
	-	48M	30000	
■ Bolts and nuts	-	12M	10000	Inspect for fastness
	-	48M	30000	
■ Cables and wires	-	12M	5000	Inspect for damage, bending and routing
	-	24M	15000	
■ Pipes, ducts, hoses and sleeves	-	12M	10000	Inspect for cracks, sealing and routing
	-	48M	30000	

<b>3.1 General Specifications</b> .....	<b>2</b>
<b>3.2 Engine Specification</b> .....	<b>3</b>
<b>3.3 Maintenance Specifications</b> .....	<b>4</b>
3.3.1 Front Wheel.....	4
3.3.2 Rear Wheel .....	4
3.3.3 Brake System.....	4
3.3.4 Light, Dashboard and Switch .....	4
<b>3.4 Service Specification</b> .....	<b>5</b>
3.4.1 Valve Train&Cylinder Head .....	5
3.4.2 Lubrication System .....	6
3.4.3 Cylinder, Piston, Piston Ring and Connecting Rod .....	6
3.4.4 Clutch and Transmission.....	7
3.4.5 Cooling System .....	7
3.4.6 Air Inlet System.....	7
3.4.7 Electrical System.....	7
<b>3.5 Tighten Torque</b> .....	<b>8</b>
3.5.1 Tighten Torque Table for Vehicle .....	8
<b>3.6 Consumption Materials&amp;Assembling Materials</b> .....	<b>11</b>
3.6.1 Vehicle Consumption Materials .....	11
3.6.2 Engine Consumption Materials&Assembling Materials .....	11

## 3.1 General Specifications

Item		Specifications	
Model		<b>IBES 800-S</b>	<b>IBEX 800-T</b>   <b>IBEX 800-E</b>
Length		87.9 in. (2234 mm) (Tail box and two side boxes are excluded)	
Width		33.6 in. (853 mm) (Tail box and two side boxes are excluded)	
Height		58.1 in. (1475 mm, windshield included)	
Wheel base		60.3 in. (1531 mm)	
Engine model		Cylinder in-line, Two Cylinder, Four Stroke, Liquid Cooled, DOHC	
Displacement		799 cc	
Fuel grade		RQ-95 or above E5	
Curb weight		509.3 lb. (231 kg)	546.7 lb. (248 kg)
Passengers		2 people (including driver)	
Tire	Front	110/80 R19	
	Rear	150/70 R17	
Min. ground clearance		190 mm	
Turning circle diameter		4700 mm	
Steering	Steering angle	Right	35°
		Left	35°
Brake system	Front	Hydraulic Disc	
	Rear	Hydraulic Disc	
Shock absorber	Suspension	Front wheel	Telescopic
		Rear wheel	Cantilever type
Frame		Steel tube	

Item		Standard
Fuel supplier	Fuel capacity	19.2 L
	Injector	Type: F01R00MG63
	Fuel pump	Voltage: DC13.5V
		Pressure: 0.33MPa ± 0.01MPa
		Flow: ≥45 L/h
	Current: ≤2.80 A	

Front shock absorber travel	6.3 in (160 mm)
Front shock absorber rebound damping adjustment	Factory setting: 10 Total available settings: 20±2
Front shock absorber compression damping adjustment	Factory setting: 10 Total available settings: 20±2
Rear shock absorber travel	1.9 in (47.5 mm)
Rear shock absorber rebound damping adjustment	Factory setting: 10 Total available settings: 20±2
Rear shock absorber compression damping adjustment	Unadjustable
Rear shock absorber spring preload	Factory setting: 4.3 in (108 mm) (distance from the upper end of the spring to the center of the upper mounting hole of the shock absorber)

## 03 Technical Information

Rear shock absorber spring preload	Adjustable range: 4.1 in ~ 4.4 in (104 mm ~ 112 mm) (distance from the upper end of the spring to the center of the upper mounting hole of the shock absorber)
------------------------------------	--

### 3.2 Engine Specification

Item		Type/Specification			
Type		Line engine, twin-cylinder, 4-stroke, water-cooled, DOHC			
Bore x Stroke		88 mm x 65.7 mm			
Displacement		799 mL			
Compression ratio		12.7:1			
Low idling speed (Idling)		1610 r/min ± 150 r/min (IBEX 800)			
Starting		Electric			
Power		77 kw/7500 rpm (IBEX 800)			
Electrical system	Ignition type	ECU			
	Spark plug/Electrode gap	NGK LMAR9AI-10 1.0 mm			
	Magneto type	PM three phase AC 29A/350W			
Combustion system	Combustion chamber	Triangular			
	Air filter type	pape filter			
	Gasoline	RQ-95 and above E5			
Valves system	Valves type	SOHC/chain drive			
Lubrication system	Lubrication type	Pressure and splash			
	Oil pump type	Rotor drive			
	Oil filter type	Paper type, replaceable			
	Engine oil type	SAE10W/50 SJ, JASOMA2			
Cooling system	Cooling type	Closed coolant circulation			
	Coolant type	-35°C anti-rust and anti-freeze fluid			
Drive train system	Clutch		Wet and multi-plate clutch		
	Transmission type		6-gear, constant mesh, step transmission		
	Reducer gear		6 gears		
	Gearshift methods/orders		Mechanical reciprocating 1-0-2-3-4-5-6-5-4-3-2-0-1		
	Transmission ratio	Primary ratio		1.923	
		Final ratio		2.813	
		Secondary ratio	1st		2.846
			2nd		2.000
3rd			1.550		
4th			1.273		
5th			1.083		
6th		0.957			
Overall size		L(mm)×W(mm)×H(mm): 425 mm x 403 mm x 520 mm			
Dry weight		55 kg			
Output type		Chain			
Rotation of engine output		When moving forward, counter clockwise(left view).			

© CFMOTO Powersports, Inc. This manual is subject to all applicable copyright laws. Reproduction or duplication in any form, whole or in part, is strictly prohibited.

## 3.3 Maintenance Specifications

### 3.3.1 Front Wheel

Item		Standard	Service limit	
Front wheel	Front wheel shaft bending	-	0.2 mm	
	Rim run-out	Longitudinal	0.8 mm	
		Horizontal	0.8 mm	
	Tire	Remaining groove	-	1.6 mm
		Tire pressure	34.8 psi (240 kPa)	-

### 3.3.2 Rear Wheel

Item		Standard	Service limit	
Rear wheel	Rim run-out	Longitudinal	0.8 mm	
		Horizontal	0.8 mm	
	Tire	Remaining groove	-	1.6 mm
		Tire pressure	40.6 psi (280 kPa)	-

### 3.3.3 Brake System

Item		Standard	Service limit
Front brake	Front (hand) brake free travel	10mm~15mm	-
	Brake disc abrasion	4.5 mm	3.5 mm
Rear brake	Rear (foot) brake free travel	5mm~10mm	-
	Brake disc abrasion	5 mm	4 mm

### 3.3.4 Light, Dashboard and Switch

Item	Standard	
Fuse	Primary	30 A
	Subsidiary	1x7.5A 1x10A 5x15A
Light, bulb	Headlight (Hi/Lo)	LED
	Position light	LED
	Tail light	LED
	Turn light	LED
	License light	LED

## 3.4 Service Specification

### 3.4.1 Valve Train&Cylinder Head

Item	Standard		Service limit	Remark
	283MW			
Valve clearance (cold engine)	IN	0.10mm~0.15mm	-	
	EX	0.15mm~0.20mm	-	
Clearance, valve guide and valve stem	IN	0.01mm~0.037mm	-	
	EX	0.03mm~0.057mm	-	
I.D of valve guide	IN & EX	4.5mm~4.512mm	-	
O.D of valve stem	IN	4.475mm~4.490mm	-	
	EX	4.455mm~4.470mm	-	
Free length, valve spring	41.6mm		-	
Valve spring force	When compressed to 38.4mm, 103N~121N		-	
	When compressed to 30.5mm, 422N~466N		-	
	When compressed to 29.8mm, 455N~503N		-	
Camshaft lift	IN	36.543mm~36.657mm	-	
	EX	35.843mm~35.957mm	-	
Camshaft to hole clearance	0.028mm~0.071mm		-	
O.D of camshaft	23.950mm~23.972mm		-	
I.D of camshaft mating hole	24mm~24.021mm		-	
Camshaft run-out	0.02mm		-	
Cylinder head junction surface flatness	0.05mm		-	

© CFMOTO Powersports, Inc. This manual is subject to all applicable copyright laws. Reproduction or duplication in any form, whole or in part, is strictly prohibited.

## 3.4.2 Lubrication System

Item	Standard	Service limit	Remark
Outer rotor to inner rotor clearance	≤0.20mm	-	
Outer rotor to pump body clearance	≤0.15mm	-	
Oil pressure	1.4bar @ 1500r/min 2.4bar @ 6000r/min	-	
Oil type	10W-50/SJ, JASOMA2	-	
Oil capacity	Change oil and filter	2800 mL	-
	At overhaul	2900 mL	-

## 3.4.3 Cylinder, Piston, Piston Ring and Connecting Rod

Item	Standard		Service limit	Remark
	283MU			
Clearance between piston and cylinder	0.035mm~0.070mm		-	
Dia. of piston skirt	82.920mm~87.980mm		-	
I.D of cylinder	88.000mm~88.012m m		-	
Cylinder junction surface flatness	0.03mm		-	
Piston ring closed clearance	1 Ring	0.25mm~0.40mm	-	
	2 Ring	0.40mm~0.55mm	-	
Clearance between piston ring and groove	1 Ring	0.03mm~0.07mm	-	
	2 Ring	0.02mm~0.06mm	-	
Thickness of piston ring	1 Ring	0.87mm~0.89mm	-	
	2 Ring	0.97mm~0.99mm	-	
Width of piston ring groove	1 Ring	0.92mm~0.94mm	-	
	2 Ring	1.01mm~1.03mm	-	
	Oil ring	1.510mm~1.525mm	-	
O.D of piston pin	18.996mm~19mm		-	
I.D of connecting rod small end	19.01mm~19.02mm		-	
Connecting rod big end side clearance	41mm~41.015mm		-	
Connecting rod big end thickness	22.85mm~22.9mm		-	
Crankshaft run-out	0.02mm		-	

## 3.4.4 Clutch and Transmission

Item	Standard	Service limit	Remark
Friction disc A		-	
Quantity	3	-	
Friction disc B		-	
Quantity	4	-	
Steel disc A		-	
Quantity	5	-	
Steel disc B		-	
Quantity	1	-	
Friction pad thickness	0.15mm	0.30mm	
Free length of clutch spring	51.7mm~52.7mm	50.7mm	
Quantity	3	-	
Shift fork thickness	4.8mm~5.0mm	-	

## 3.4.5 Cooling System

Item	Standard/Specification	Service limit	Remark
Start temp. of thermostat	72°C~85°C	-	
Lift range of thermostat valve	≥8 mm at 85°C	-	
Open pressure of radiator cap	135kPa~160kPa(standard:140kPa)	-	
The relationship between the resistance of water temp. sensor and temperature	Temperature (°C)	-	
	-20	-	
	20	-	
	80	-	
Coolant type	120	-	
	-35°C anti-rust and anti-freeze fluid with high boiling point	-	

## 3.4.6 Air Inlet System

Item	Specification	Remark
Port size (mm)	φ42 mm	
Idle speed (r/min)	1610 r/min ± 150 r/min (IBEX 800)	

## 3.4.7 Electrical System

Item	Specification		Remark
Spark plug	Model	NGK LMAR9AI-10	
	Gap	1 mm	
Spark	> 8 mm, 1MPa		
Ignition coil resistance	Primary	1.23 Ω	
	Secondary	6kΩ~13kΩ	
Magneto coil resistance	Trigger	400Ω	
Max power	350W		
Stabilized voltage	13.5V~15.0V		
Primary peak voltage, ignition coil	≥27kV		
Peak voltage, trigger coil	≥17V		

## 3.5 Tighten Torque

### 3.5.1 Tighten Torque Table for Vehicle

Item	Torque N•m(kgf•m)	Item	Torque N•m(kgf•m)
M5 bolt, nut	5±1(0.5±0.1)	M5 screw	4±1(0.4±0.1)
M6 bolt, nut	10±1(1.0±0.1)	M6 screw	9±1(0.9±0.1)
M8 bolt, nut	20~30(2.0~3.0)	M6 flange bolt and nut	12±1(1.2±0.1)
M10 bolt, nut	30~40(3.0~4.0)	M8 flange bolt and nut	20~30(2.0~3.0)
M12 bolt, nut	40~50(4.0~5.0)	M10 flange bolt and nut	30~40(3.0~4.0)

Please use standard torque if without torque value mentioned below table.

**NOTE: 1. Lubrication oil should be applied on screw thread and contact surface.  
2. Replace with new ones if self-locking bolts are removed.**

Mounting place	Item	Torque N•m&Thread locker
Oxygen sensor	Oxygen sensor	50N•m
Nut, front exhaust pipe	Muffler nut	Inside 20N•m (1) Outside 12N•m (2) Inside 20N•m (1)
Bolts, front muffler body	Bolt M8*30	25N•m(medium-strength thread locker 243)
Side stand switch	Bolt M5	4N•m(medium-strength thread locker 243)
Lock nut, rear brake lever	Nut M8	25N•m(medium-strength thread locker 243)
Lock nut, gearshift lever pedal	Nut M8	25N•m(medium-strength thread locker 243)
Dual hydraulic sensor switch	Dual hydraulic sensor switch	20N•m
Rear brake fluid inlet pipe	Banjo bolt II	25N•m
Front brake fluid outlet pipe	Banjo bolt II	25N•m
	Screw M10*45	48N•m(medium-strength thread locker 243)
Lower bolt, LH front footrest	Bolt M10*87	45N•m(medium-strength thread locker 243)
Lower bolt, LH front footrest	Bolt M10*1.25*40	45N•m(medium-strength thread locker 243)
Lower bolt, RH front footrest	Bolt M10*1.25*40	45N•m(medium-strength thread locker 243)
Connecting bolt, engine bracket and engine	Bolt M10*60	45N•m(medium-strength thread locker 243)
Bracket, middle supporter	Bolt M10*45	45N•m(medium-strength thread locker 243)
	Bolt M10*30	
Connecting bolt, engine bracket and frame	Bolt M8*50	28N•m(medium-strength thread locker 243)
Upper bolt, front footrest	Bolt M12*60	100N•m
Bolt, rear shock absorber	Shock absorber bolt (lower or upper) M12*60	80N•m(medium-strength thread locker 243)
Nut, output shaft	Small sprocket output shaft lock nut	120N•m(medium-strength thread locker 243)

## 03 Technical Information

Bolt, frame	Frame upper lock bolt M10*22	60N•m(High-strength thread locker 2701)
Bolt, frame	Frame lower lock bolt M10*37	60N•m(High-strength thread locker 2701)
Handlebar seat	Inner hex screw M10*1.25*60	45N•m(medium-strength thread locker 243)
Front brake master cylinder	Come with	2N•m
RH handlebar switch	Come with	2N•m
E-throttle	Come with	2N•m
Clutch lever assy	Come with	2N•m
LH handlebar switch	Come with	2N•m
LH hand grip assy	Come with	2N•m
Steering stem	Lock screw M25*1.5	21N•m
Front brake master cylinder pipe	Banjo bolt II	25N•m
Front shock absorber, lower triple clamp	Screw M8*30	Upper 20N•m(medium-strength thread locker 243) Lower 16N•m(medium-strength thread locker 243)
Screw, upper triple clamp	Inner hex screw M8*30	20N•m(medium-strength thread locker 243)
	Inner hex screw M8*25	20N•m(medium-strength thread locker 243)
Nut, rear sprocket	Nut M25*1.5	90N•m
Fuel pump	Bolt M6*16	5N•m
Screw, front wheel shaft	Front wheel shaft screw M25*1.5	45N•m
Front brake caliper	Bolt M10*1.25*60	45N•m(medium-strength thread locker 243)
Brake fluid pipe	Banjo bolt	25N•m
Rear footrest	Screw M8*20	25N•m(medium-strength thread locker 243)
Rear muffler	Inner hex screw M8*52	25N•m(medium-strength thread locker 243)
Small sprocket guard	Screw kit M5	5N•m(medium-strength thread locker 243)
Gearshift rod and gearshift seat	GB70.2 M6*16	6N•m(medium-strength thread locker 243)
Front bumpers	Bolt M8*20	25N•m(medium-strength thread locker 243)
Bumper connecting pipe	Bolt M8*20	25N•m(medium-strength thread locker 243)
Rear seat	Bolt M8*35	25N•m(medium-strength thread locker 243)
Rear armrest deco cover	Screw kit M5	6N•m(medium-strength thread locker 243)
Side box bracket	Screw M8	25N•m(medium-strength thread locker 243)

© CFMOTO Powersports, Inc. This manual is subject to all applicable copyright laws. Reproduction or duplication in any form, whole or in part, is strictly prohibited.

© CFMOTO Powersports, Inc. This manual is subject to all applicable copyright laws. Reproduction or duplication in any form, whole or in part, is strictly prohibited.

Side box bracket connecting lever	Flange bolt M8	25N•m(medium-strength thread locker 243)
Middle supporter	Screw M8	30N•m(medium-strength thread locker 243)
Screw, front brake disc	Screw M8*25	25N•m(medium-strength thread locker 243)
Screw, rear brake disc	Screw M8	25N•m(medium-strength thread locker 243)
Rear sprocket	Sunk screw M8*28	38N•m(High-strength thread locker 2701)

## 3.6 Consumption Materials&Assembling Materials

Consumption materials include lubricant oil (engine oil), lubricant grease (butter) and coolant. Assembling materials include flange sealants, thread locker.

### 3.6.1 Vehicle Consumption Materials

Application areas	Notes	Type
Vehicle's head pipe, bearing races Front wheel dust-proof seal lip Rear brake cam movable parts, cam Junction, dashboard soft shaft Shaft joint, throttle cable Throttle handlebar part Pivot, rear pedal(LH), Pivot, rear pedal(RH), Pivot, side stand Rear fork oil seal lip Counter gear/small gear surface and movable parts Main bracket shaft		Multi-purpose lithium base lubrication oil GB/T5671
Thread of rear wheel axle nut and joint Handle bar inner surface		Engine oil
Lower dust-proof seal lip of front shock absorber		Absorber oil 5#

### 3.6.2 Engine Consumption Materials&Assembling Materials

Item	Specification	Using parts	Remark
Lubricant oil	SAE10W-50 SJ, JASOMA2	Rotation and moving section in cylinder, crankcase and cylinder head.	Oil Capacity: 2800mL
Lubricant oil with molybdenum		Piston pin, valve stem, valve oil seal, camshaft	
Lubricant grease	#3 MoS2 lithium grease	Oil seal, o-ring and rubber seal face, bearing with sealant	
Coolant	-35°C anti-rust and anti-freeze fluid with high boiling point	Cooling system, water seal installation	Capacity depends on radiator water pipes
Flange sealant		Crankcase faying face , crankcase and cylinder joint cylinder head and cylinder head cover joint	
Tread locker		Parts of thread	

© CFMOTO Powersports, Inc. This manual is subject to all applicable copyright laws. Reproduction or duplication in any form, whole or in part, is strictly prohibited.

© CFMOTO Powersports, Inc. This manual is subject to all applicable copyright laws. Reproduction or duplication in any form, whole or in part, is strictly prohibited.

**4.1 Seat Removal .....2**

**4.2 Seat Installation .....2**

© CFMOTO Powersports, Inc. This manual is subject to all applicable copyright laws. Reproduction or duplication in any form, whole or in part, is strictly prohibited.

## 4.1 Seat Removal

- Insert key into seat lock [1].
- Unlock seat lock [1].
- Lift front part of the seat [2].
- Remove seat.

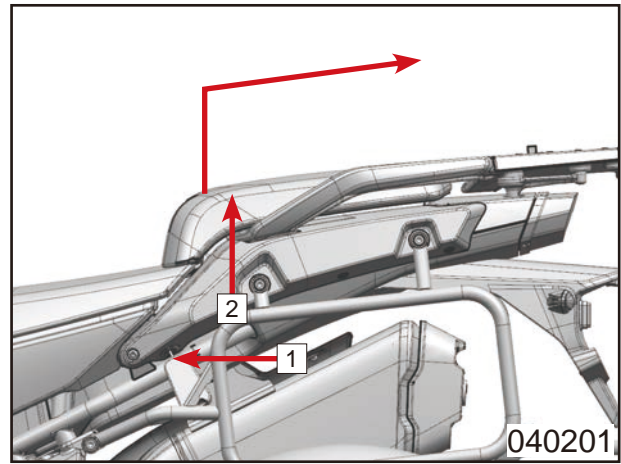

- Remove two bolts and washers [3].
- Lift rear part of the seat.
- Remove seat.

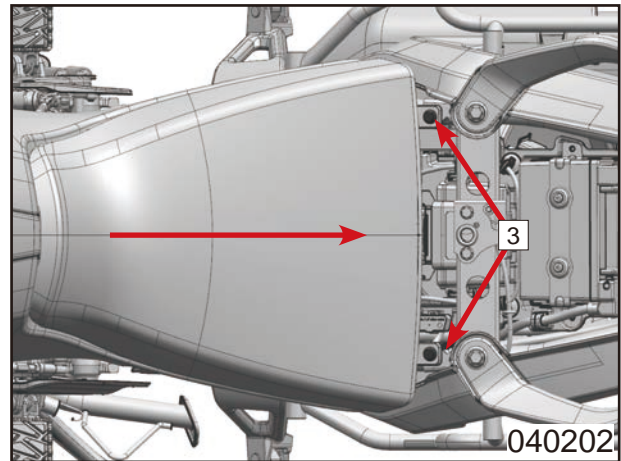

## 4.2 Seat Installation

- Insert clasp [1] into [a].
- Align four blocks with frame.
- Install two bolts [2].
- Insert two hooks into holes [b].
- Compress columns [3] into seat lock [c].

**NOTE: Seat might be loose if not installed in place. Check seat after installation.**

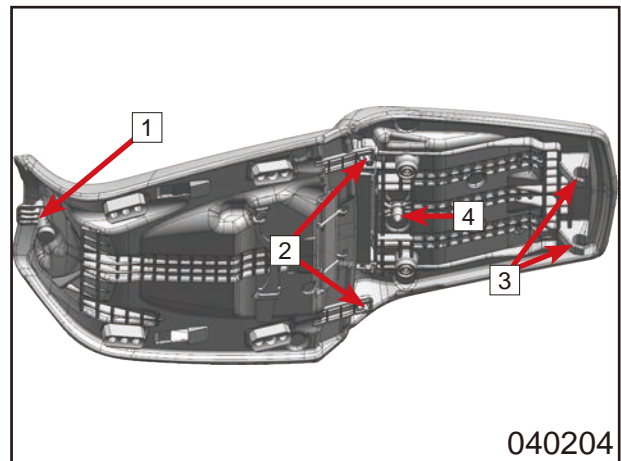
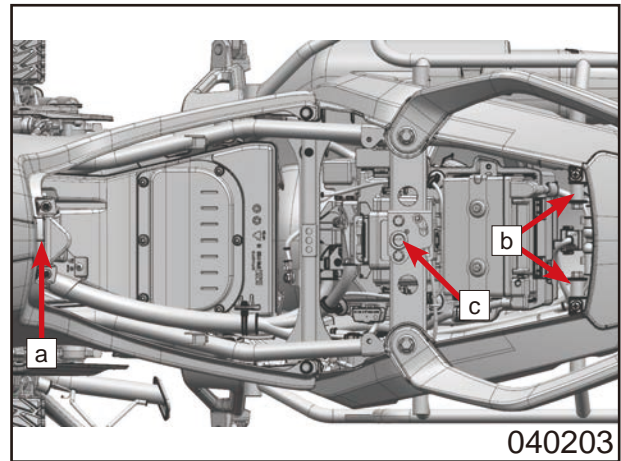

## 05 Body Covering Parts

---

5.1 Windshield .....	2
5.2 LH&RH Steering Panels .....	3
5.3 LH&RH Fog Light Guards .....	3
5.4 Bumpers .....	3
5.5 Fuel Tank Lower Panels and Fog Light Assy.....	5
5.6 Fuel Tank LH&RH Front Panels.....	5
5.7 Fuel Tank Guard .....	6
5.8 Dashboard.....	7
5.9 Headlight Assy.....	7
5.10 Rear Armrest.....	8
5.11 Side Box Bracket .....	8
5.12 Tail Light LH&RH Panels.....	9
5.13 Tail Light Upper Cover .....	9

## 5.1 Windshield

Remove inner hex bolts [1].

Remove windshield [2].

Inner hex bolt [1] torque: 6 N•m ~ 8 N•m

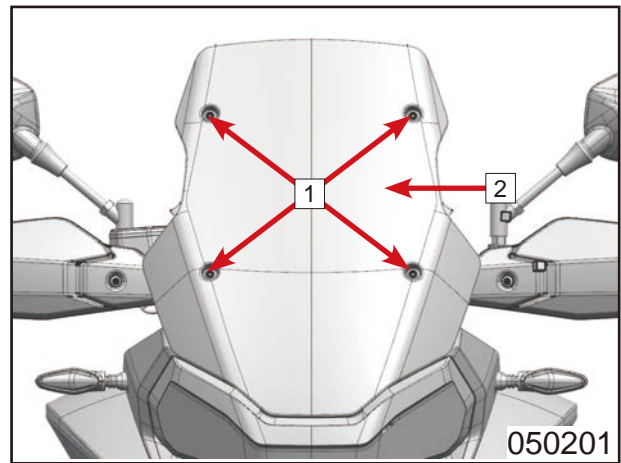

Remove inner hex bolts and washers [3].

Remove small windshields [4].

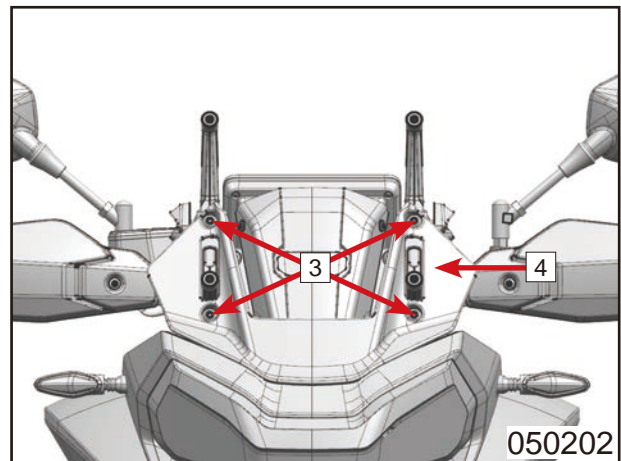

Remove expansion screws [5].

Remove screws [6].

Remove dashboard front guard [7].

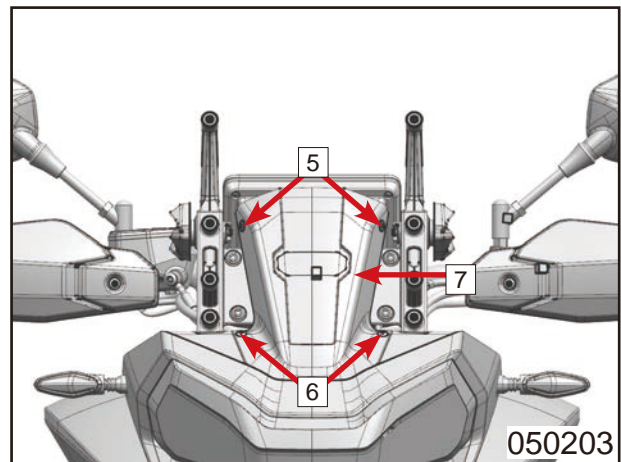

Remove inner hex bolts [8].

Remove LH&RH windshield brackets [9].

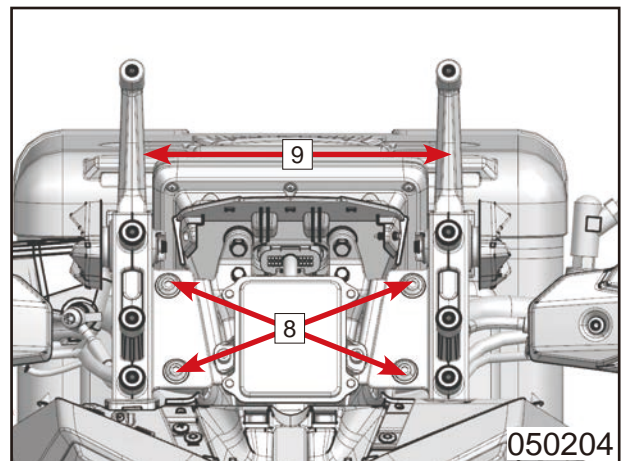

## 05 Body Covering Parts

### 5.2 LH&RH Steering Panels

Remove inner hex bolts **1** on both sides.  
Remove expansion screws **2** on both sides.  
Remove expansion screws **3** on both sides.  
Remove LH&RH steering panels **4**.  
Unplug USB connector and 12V power connector.

**NOTE: 12V power connector may not removed immediately.**

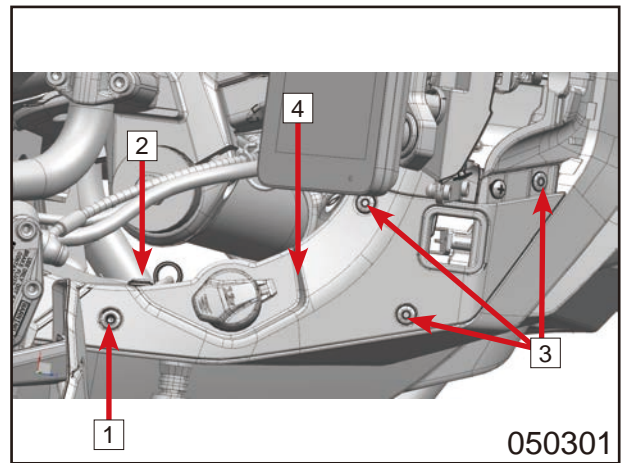

### 5.3 LH&RH Fog Light Guards

Remove inner hex bolts **1** on both sides.  
Remove LH&RH fog light guards **2**.

**NOTE: Use extension lever to remove upper inner hex bolts if necessary.**

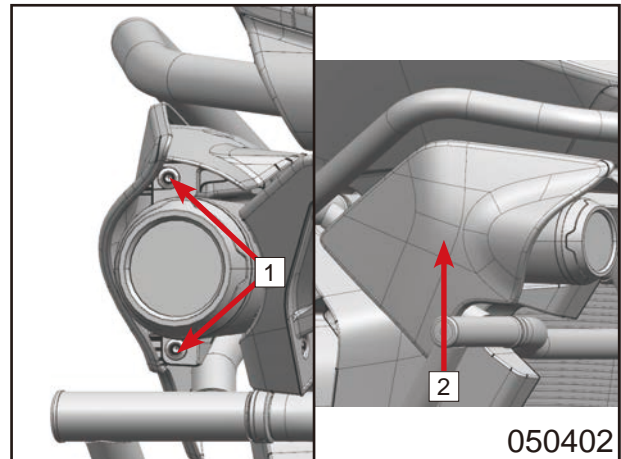

Remove inner hex bolts **3** on both sides.  
Remove LH&RH fog light brackets **4**.

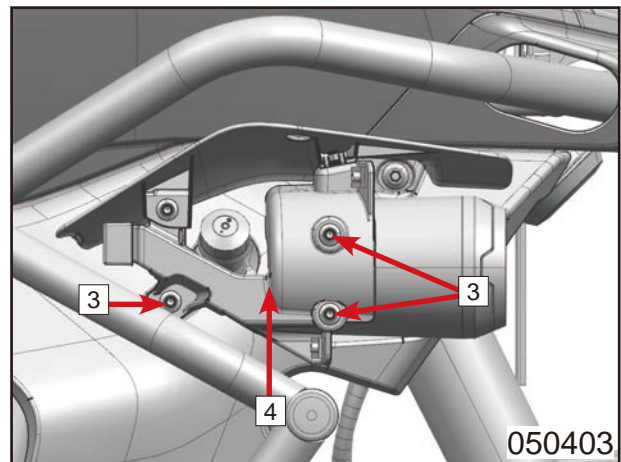

### 5.4 Bumpers

Remove inner hex bolt **1** on the back.  
Remove bumper deco covers **2**.  
Remove bolts **3**.

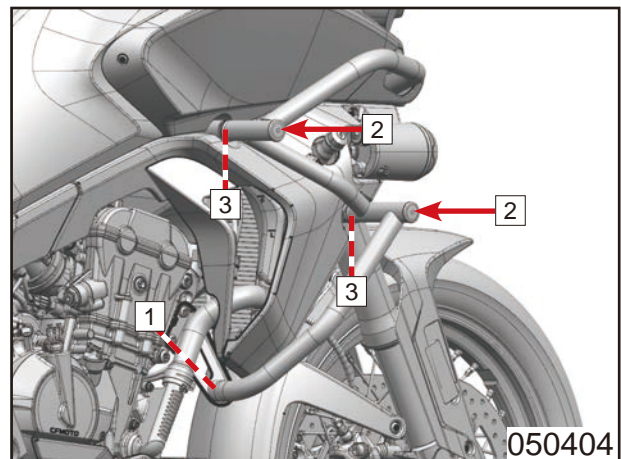

© CFMOTO Powersports, Inc. This manual is subject to all applicable copyright laws. Reproduction or duplication in any form, whole or in part, is strictly prohibited.

Remove bolt [4].  
Remove RH bumper [5].

**NOTE: Be careful not to drop bumper during removal.**

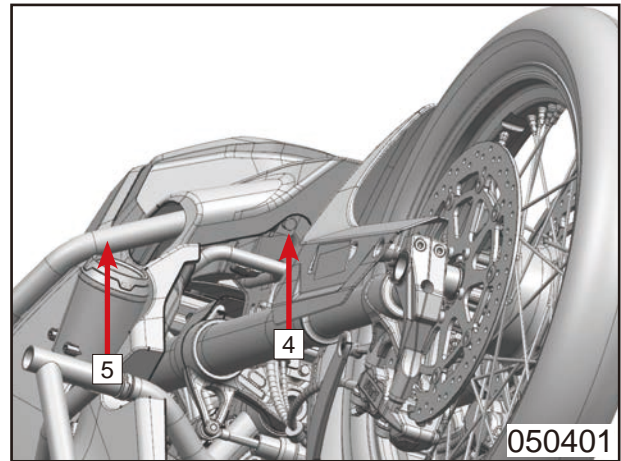

Remove inner hex bolt [6] on the back.  
Remove bumper deco cover [7].  
Remove bolt [8].

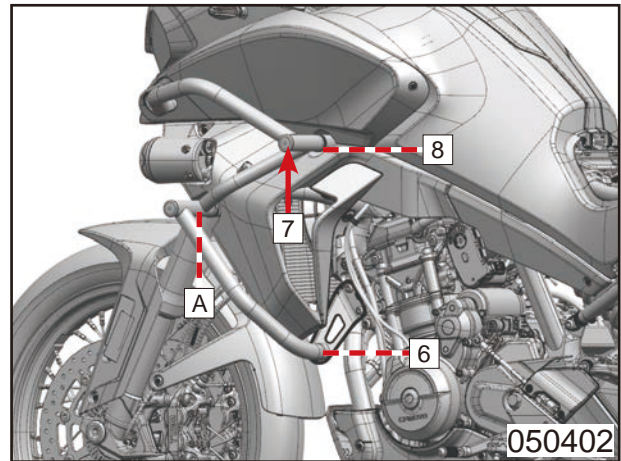

Remove bolt [9].  
Remove LH bumper [10].

**NOTE: Be careful not to drop bumper during removal.**  
**Loosen bolt A to help removing bumper if necessary.**

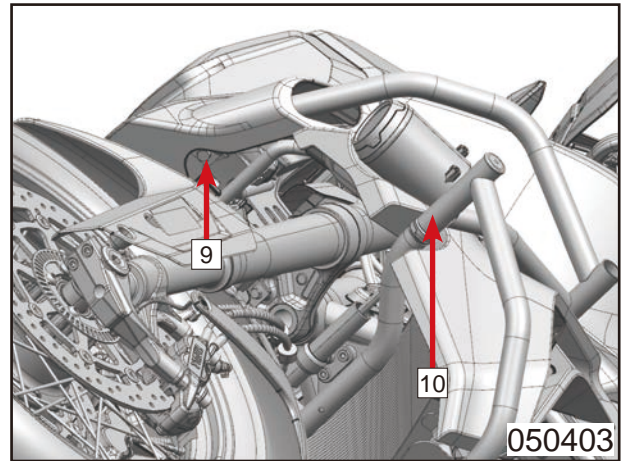

## Radiator LH&RH Rear Panels

Remove inner hex bolts [1] on both sides.  
Loosen tab A towards back side of the vehicle to remove radiator LH&RH rear panels [2].

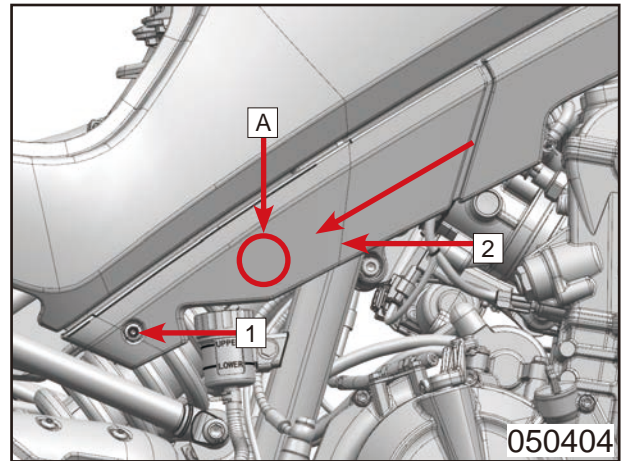

## 05 Body Covering Parts

### 5.5 Fuel Tank Lower Panels and Fog Light Assy

Remove inner hex bolts **1** on both sides.  
Remove expansion screws **2** on both sides.

Remove inner hex bolts **3** on both sides.

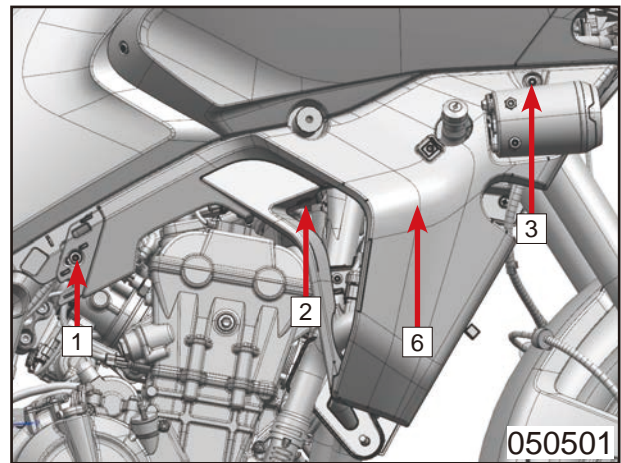

Remove bolts **4** on both sides.

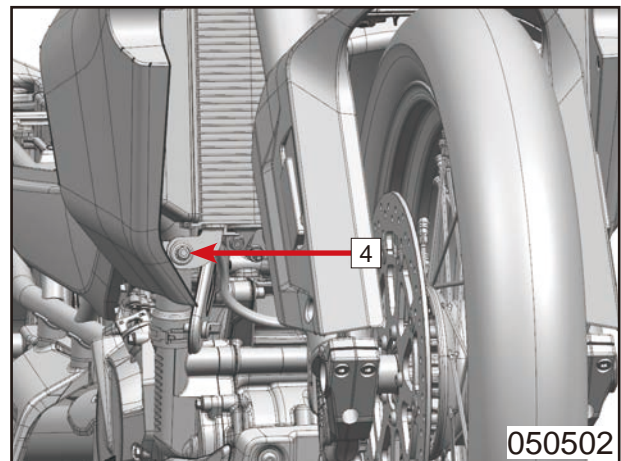

Remove expansion screws **5**.  
Unplug connectors.  
Remove fuel tank lower panels and fog light assy **6**.

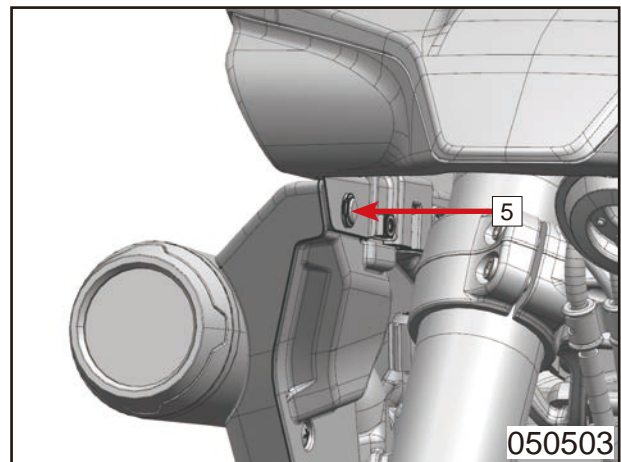

### 5.6 Fuel Tank LH&RH Front Panels

Remove inner hex bolts **1** on both sides.

Remove screws **2** on both sides.

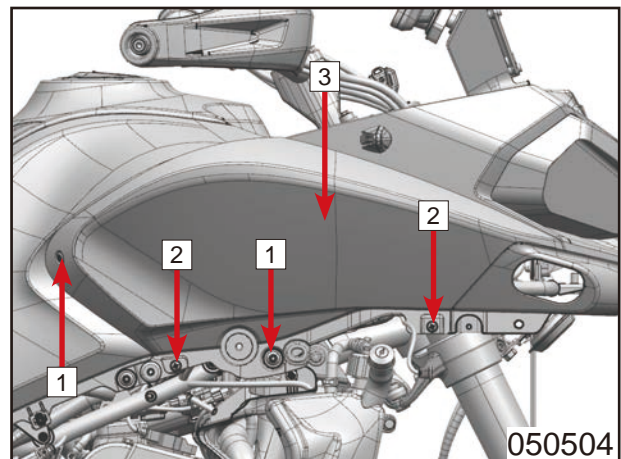

© CFMOTO Powersports, Inc. This manual is subject to all applicable copyright laws. Reproduction or duplication in any form, whole or in part, is strictly prohibited.

Remove screws **2** on both sides.

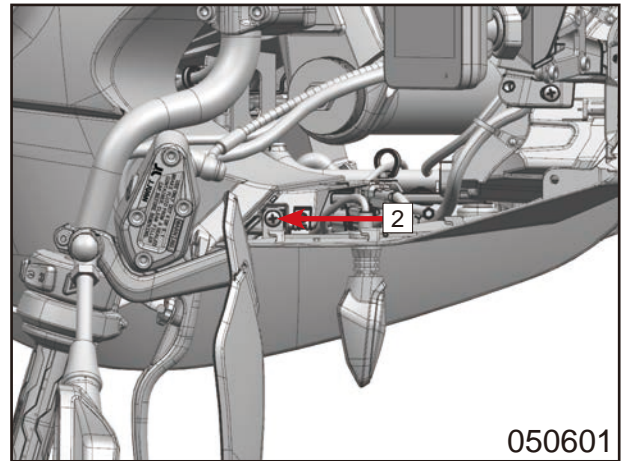

050601

Remove screws **2** on both sides.  
Remove fuel tank LH&RH front panels **3**.

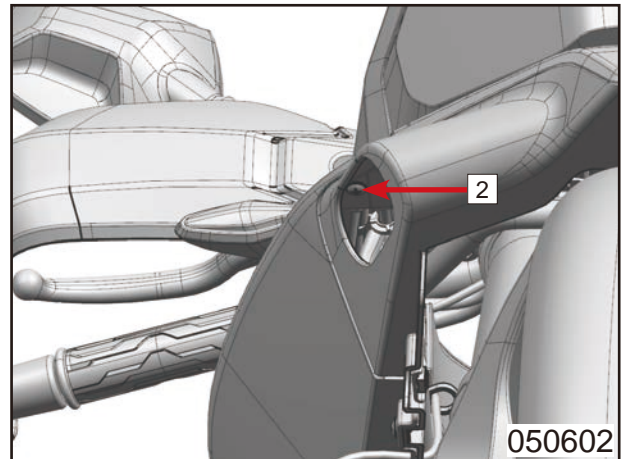

050602

## 5.7 Fuel Tank Guard

Remove inner hex bolts **1**.  
Remove fuel tank cap **2**.

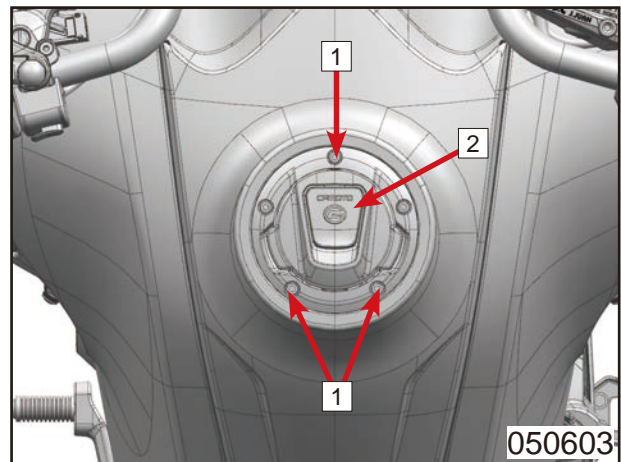

050603

Remove expansion screws **3** on both sides.  
Remove inner hex bolts **4** on both sides.  
Remove screws **5** on both sides.  
Remove fuel tank guard **6**.

**NOTE: Loosen handlebar and adjust handlebar angle to help remove fuel tank guard if necessary.**

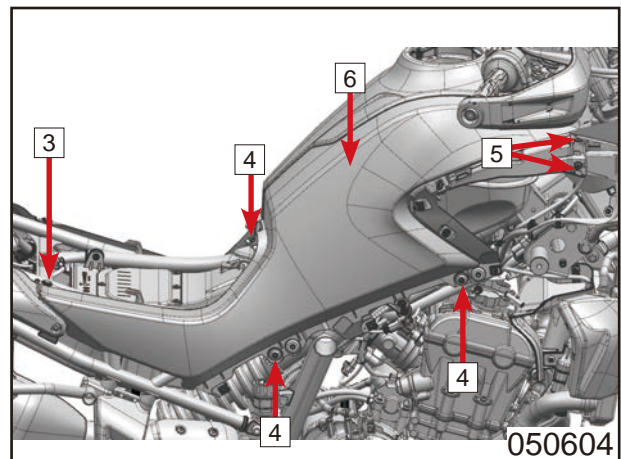

050604

© CFMOTO Powersports, Inc. This manual is subject to all applicable copyright laws. Reproduction or duplication in any form, whole or in part, is strictly prohibited.

## 05 Body Covering Parts

Install fuel tank cap **2**.

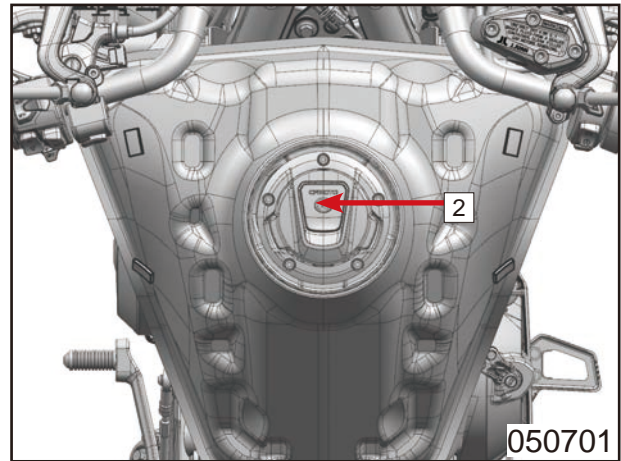

### 5.8 Dashboard

Remove inner hex bolts **1**.  
Unplug connectors.  
Remove headlight controller **2**.

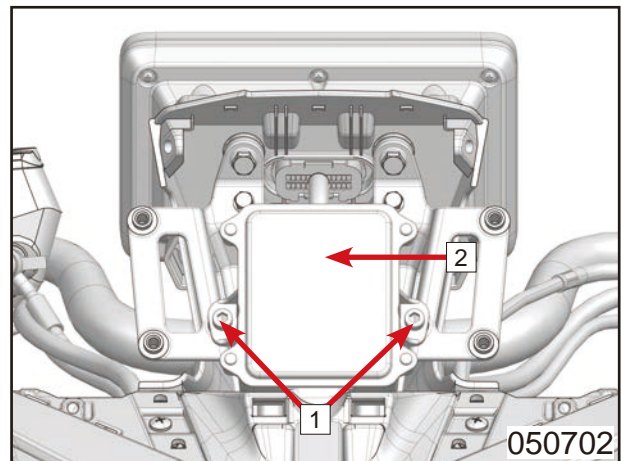

Remove bolts **3**.  
Unplug connectors.  
Remove dashboard **4**.

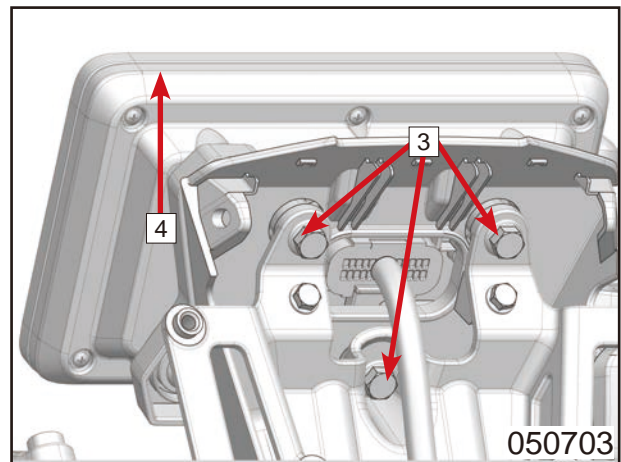

### 5.9 Headlight Assy

Remove inner hex bolts **1** on both sides.  
Remove bolts **2**.  
Remove clasps below.  
Unplug connectors.  
Remove headlight assy **3**.

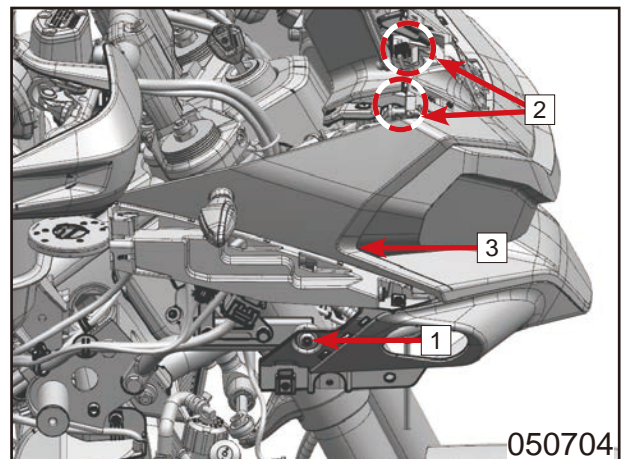

© CFMOTO Powersports, Inc. This manual is subject to all applicable copyright laws. Reproduction or duplication in any form, whole or in part, is strictly prohibited.

## 5.10 Rear Armrest

Remove inner hex bolts **1**.  
Remove tail box bracket **2**.

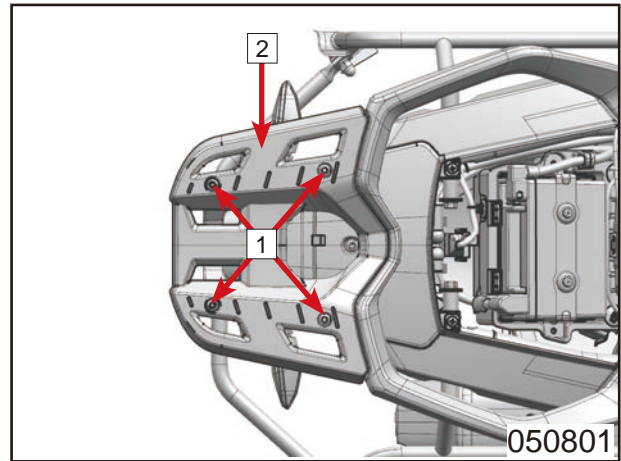

Remove inner hex bolts **3**.  
Remove the bolt **4**.  
Remove rear armrest **5**.

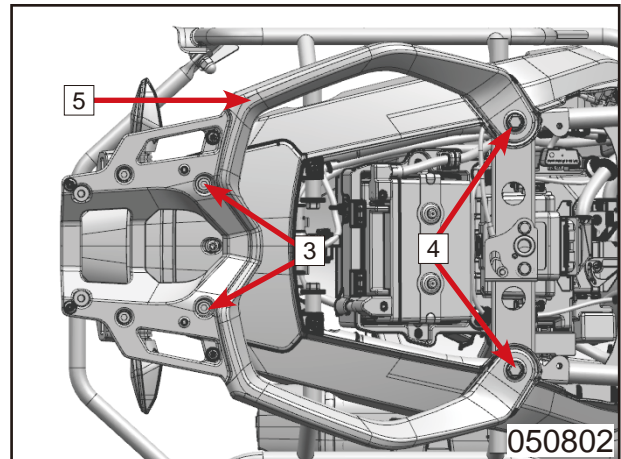

## 5.11 Side Box Bracket

Remove inner hex bolts **1** on both sides.

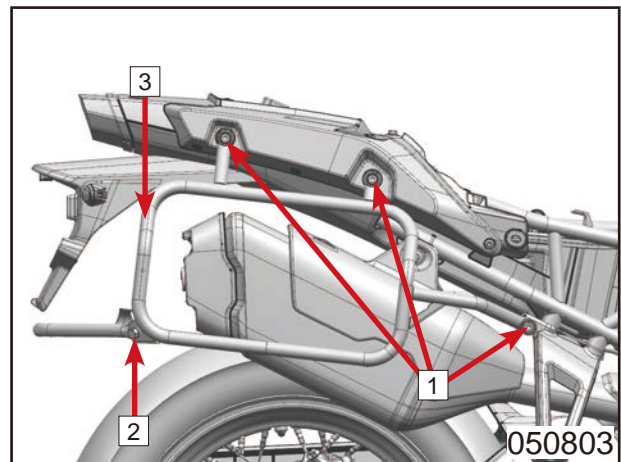

Remove inner hex bolts **1** on both sides.  
Loosen bolts **2**.  
Remove side box brackets **4**.

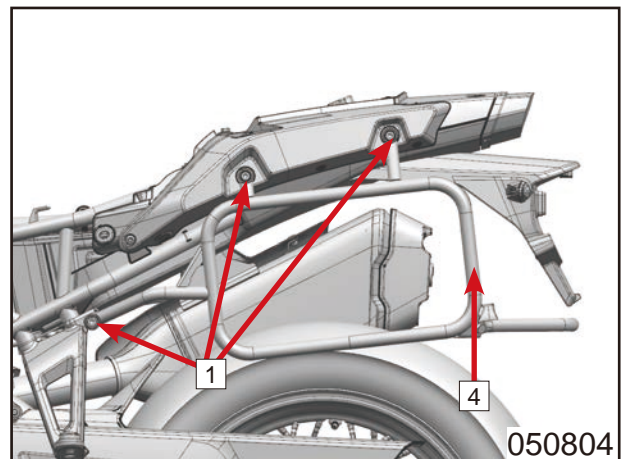

## 05 Body Covering Parts

### 5.12 Tail Light LH&RH Panels

Remove LH&RH screws **1**.

Remove inner hex bolts **2** on both sides.

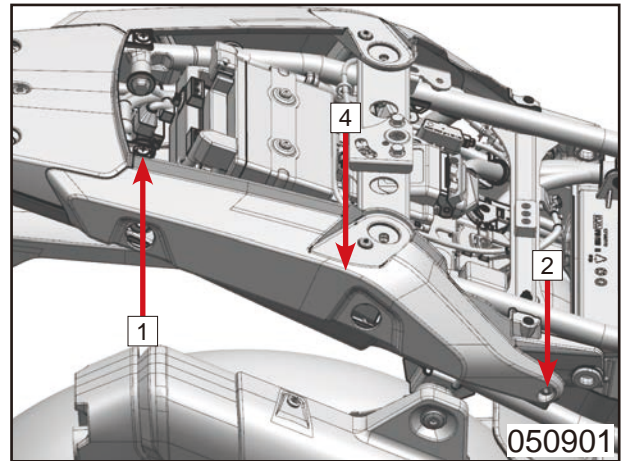

Remove expansion screws **3** on both sides.

Remove tail light LH&RH panels **4**.

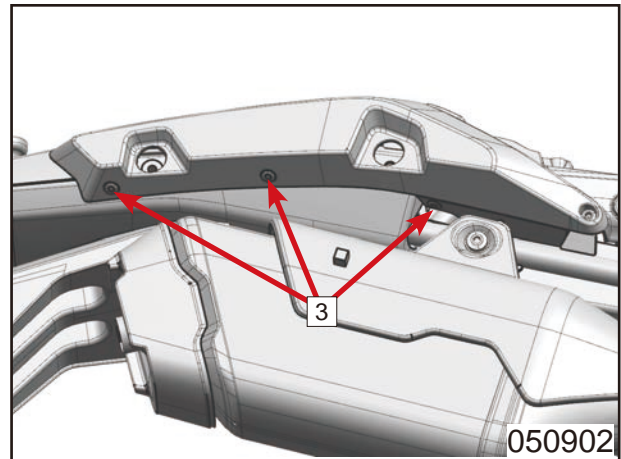

### 5.13 Tail Light Upper Cover

Remove screws **1**.

Remove inner hex bolts **2**.

Remove tail light upper cover **3**.

**NOTE: Do not lose lock strip **4**.**

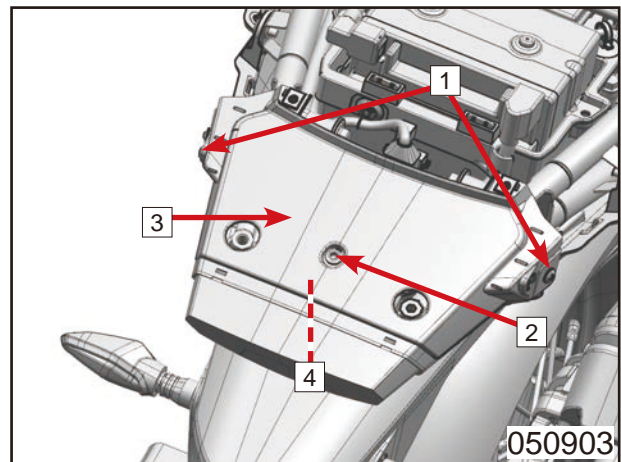

© CFMOTO Powersports, Inc. This manual is subject to all applicable copyright laws. Reproduction or duplication in any form, whole or in part, is strictly prohibited.

6.1 Fuel Tank Removal .....	3
6.2 EVAP System .....	3
6.3 Fuel Pump .....	4
6.4 Floating Ball .....	4



## **Danger:**

In some situations, the gasoline is highly flammable and explosive.

Do not overfill the fuel tank. When the fuel reaches the neck of the oil filler, it is the maximum capacity.

The engine must be stopped when refueling and must be refueled in a well-ventilated area or outdoors

No smoking, open fire or sparkle in the refueling area or gasoline storage area.

If gasoline spills onto the skin or clothing, wash immediately with soap and water or change the clothes.

Seek medical attention immediately if accidentally contact your eyes or swallow gasoline.

## **⚠ WARNING:**

Please use genuine parts for maintenance. Otherwise, the normal operation of the electronic injection system cannot be guaranteed.

During maintenance, do not disassemble electrical parts.

Carefully handle electrical parts during maintenance.

Turn the ignition switch off during unplugging or plugging in connectors to prevent damaging electrical parts.

Do not electrify the oil pump during removal to prevent electric spark and fire.

The fuel pump is not allowed to run in dry condition or in water. Otherwise, its service life will be reduced. The positive and negative wires of the fuel pump can't be connected backwards.

The pressure is high (around 330kPa) in fuel system. All fuel hoses are high-pressure resistance. The fuel rail keeps high fuel pressure even the engine doesn't work. Do not remove fuel hose during maintenance.

Spark jumping test should be carried out only when necessary. The testing time should be as short as possible. The throttle valve should not be opened during the test. Otherwise, a large amount of unburned fuel will enter the exhaust pipe and damage the three-way catalytic converter.

When the fuel system needs to be repaired, the fuel system should be decompressed before the oil hoses are removed. The method of pressure relief: to remove the oil pump relay and start the engine to idle until the engine stops by itself.

Fuel hoses removal and fuel filter replacement shall be operated by professional technicians in a well-ventilated place.

Do not mis-connect the positive and negative pole of battery. Remove the negative wire first if disassembling battery, in case it damages electrical elements. The system of this vehicle uses negative earth mode.

Battery wires are not allowed to be removed while the engine is working.

Battery positive/negative wires and electrical control units have to be removed before welding on the vehicle.

It is forbidden to puncture the wire to test the input/output electrical signals.

Establish the awareness of environmental protection and effective disposal of waste generated during maintenance.

## 6.1 Fuel Tank Removal

Remove bolts [1].

Lift fuel tank [2].

**NOTE:** Do not lose rubber washer [A].

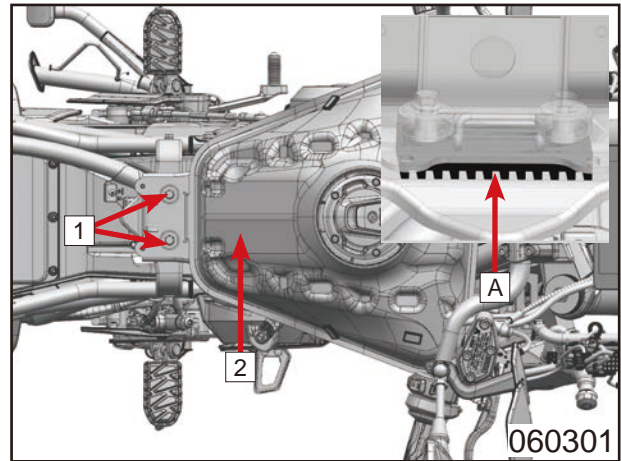

Unplug fuel adsorption pipe [3].

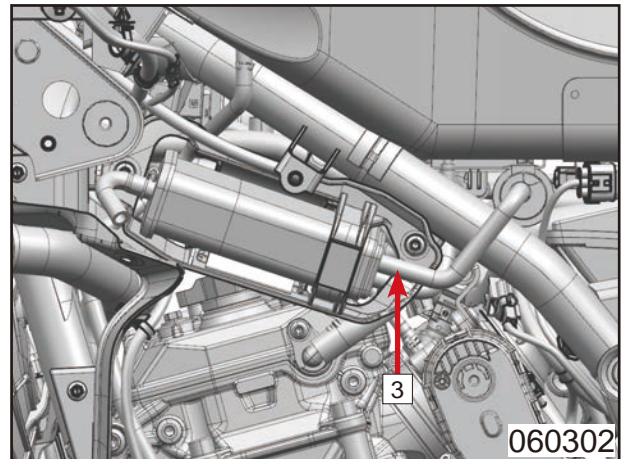

Unplug high-pressure fuel hose quick joint [4].

Remove fuel tank assy.

**⚠ Danger:** Never put fuel tank up side down to prevent fuel leaking.

**⚠ WARNING:** When installing fuel tank, all hoses, pipes and cables can not be extruded.

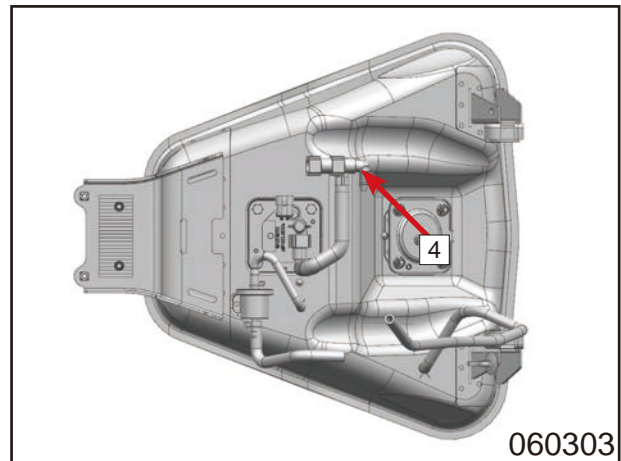

## 6.2 EVAP System

Remove throttle fuel desorption pipe [1].

Remove inner hex bolts [2].

Remove canister [3].

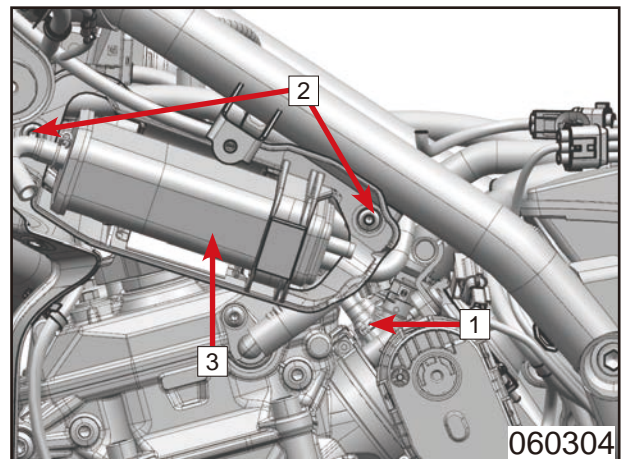

## 6.3 Fuel Pump

Release pressure in fuel system.

Ground the vehicle.

Unplug cables related to fuel pump.

Unplug quick joint. Cover with cloth to prevent fuel leaking.

Remove fuel pump cables and connectors. Clean fuel tank and fuel pump to prevent foreign matters into fuel tank.

**NOTE: Excessive foreign matter in the tank may cause the fuel pump to wear out prematurely or block fuel filter.**

Remove bolt 1 to bolt 4 in sequence.

Remove fuel pump 5 carefully.

**NOTE: There is still some fuel remained in removed fuel pump. Be careful to transfer the fuel pump into a proper container.**

**Check the fuel tank for impurities. Clean the tank thoroughly with clean fuel before reinstalling a new fuel pump. Do not use water or other chemicals to clean the tank.**

### Installation

Put the fuel pump seal ring in place from bottom to top and then position the fuel pump on the mounting hole on fuel tank assy.

**NOTE: The arrow on fuel pump aligns to fuel tank mark all the way.**

Put fuel pump cap on the junction area.

Install bolt 1 to bolt 4 in sequence.

Plug in quick joint, cables and connectors.

Start to check if fuel pump works.

Fuel pump inspection refers to 08 Electrical System.

## 6.4 Floating Ball

Release pressure in fuel system.

Ground the vehicle.

Remove four bolts 1 in criss-cross way.

Remove floating ball 2 carefully.

The floating ball is a bit bent. Lean floating ball during removal to prevent damage.

### Installation

Make sure the floating ball face toward the back side of fuel tank. Wrong direction affects the position function of fuel floating ball.

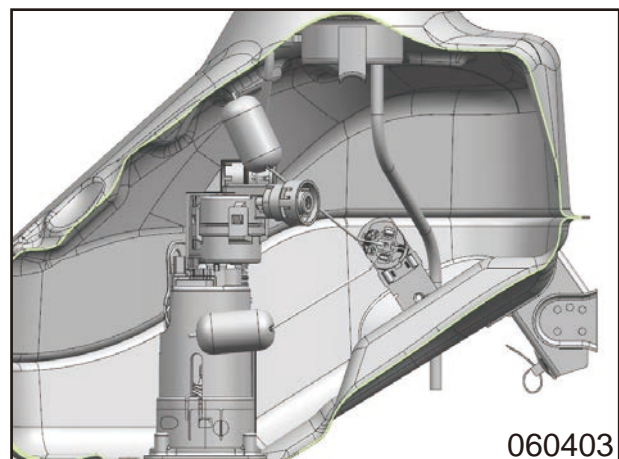
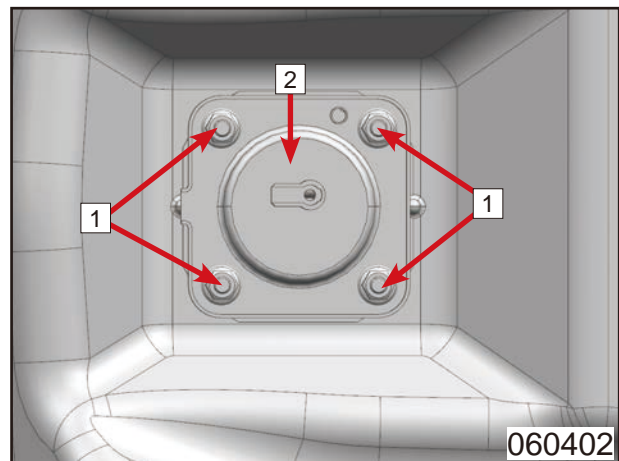
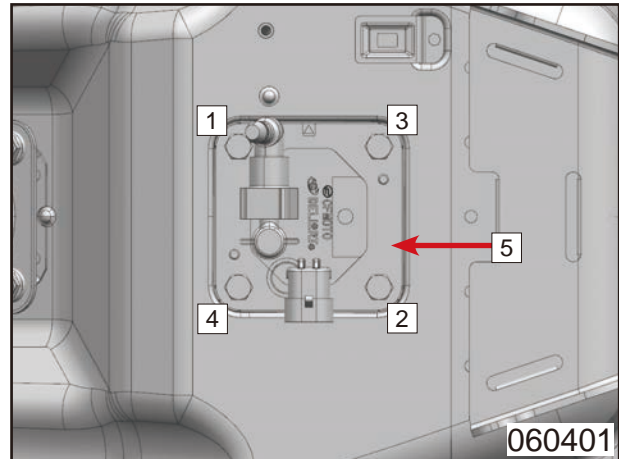

### Inspection

Inspect fuel tank if sunk, cracked or other damage. Replace if any defect is found.  
Inspect hose if cracked, aged or leaked. Replace if any defect is found.

### Installation

Reverse the removal procedures for installation.

**NOTE: When installing fuel tank, all hoses, pipes and cables can not be extruded.**

© CFMOTO Powersports, Inc. This manual is subject to all applicable copyright laws. Reproduction or duplication in any form, whole or in part, is strictly prohibited.

## 07 Lights, Dashboard and Switches

---

7.1 Maintenance Information .....	07-2
7.1.1 Operation Caution .....	07-2
7.1.2 Inspection Standard .....	07-2
7.2 Trouble Shooting .....	07-2
7.3 Turn Light .....	07-3
7.4 Tail Light/Brake Light .....	07-3
7.5 Dashboard.....	07-4
7.5.1 Dashboard(IMM) .....	07-5
7.6 Ignition Switch .....	07-6
7.7 Front Brake Light Switch .....	07-6
7.8 LH Handlebar Switch(Status 1) .....	07-7
7.9 LH Handlebar Switch(Status 2) .....	07-8
7.10 RH Handlebar Switch(Status 1).....	07-9
7.11 RH Handlebar Switch(Status 2).....	07-10
7.12 Fog Light .....	07-11
7.13 Horn .....	07-12
7.14 Fuel Level Sensor.....	07-12
7.15 Battery .....	07-13
7.16 Vehicle T-BOX .....	07-14
7.17 Ground Wire.....	07-14
7.18 Start Engine Stop Control Unit.....	07-15
7.19 Headlight Controller .....	07-16
7.20 Headlight Cable .....	07-17
7.21 Radar Sensor (Backward - Short-range ranging sensor)	07-19
7.22 Body Control Module.....	07-20
7.22.1 BCM Fault and Detection .....	07-21

## 7.1 Maintenance Information

### 7.1.1 Operation Caution

**⚠ WARNING:**  
 If the Inspection has to be done check if the battery is normal.  
 Inspection of switch continuity can be done without removing the switches from the vehicle.  
 After the inspecting and overhauling of each part, cables and wires should be routed properly.

### 7.1.2 Inspection Standard

Item		Standard
Fuse	Main fuse	30A
	Auxiliary fuse	1x7.5A 1x10A 5x15A
Light&Bulb	Headlight	High-beam LED:35W Low-beam LED:26W Position light LED:12W
	Turn light	LED:0.5Wx3
	Tail light	Rear position light LED:2W Brake light LED:1.5W
	Front fog light	LED:7.5W

## 7.2 Trouble Shooting

**Head light cannot turn on, Hi/Lo switch doesn't work:**

Probable cause:

- 1) Fuse is blown
- 2) Switch is damaged
- 3) Bulb is burnt
- 4) Bad connection
- 5) BCM fault
- 6) Headlight controller malfunction

### Headlight

#### Removal

Refer to 5.10 Headlight Assy of 05 chapter.

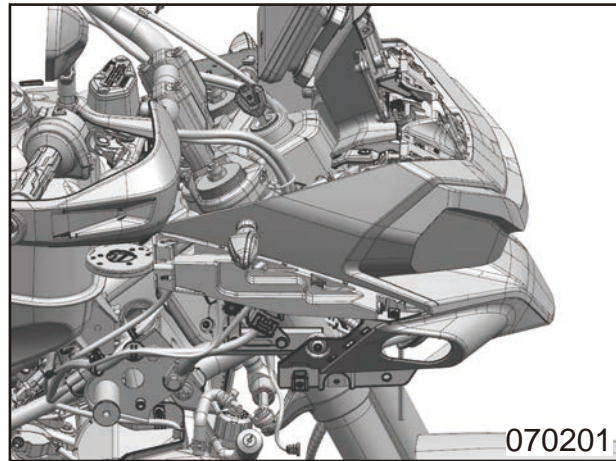

Adjust the headlight angle by adjusting the gear 1.

#### Installation

Reverse the removal procedures for installation.

**NOTE:** The headlight is consisted of LED lights. When the light damages, replace the whole set.

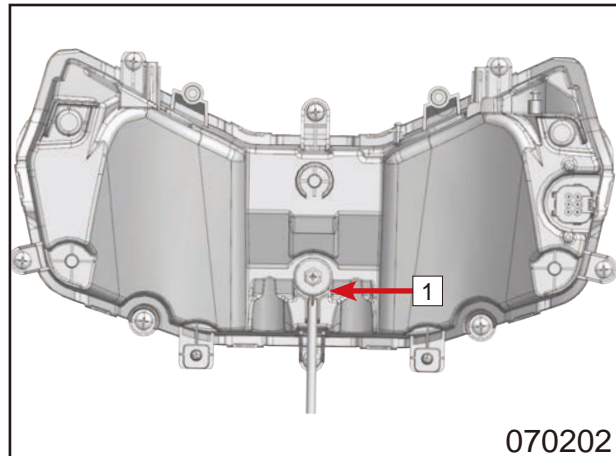

# 07 Lights, Dashboard and Switches

## 7.3 Turn Light

### Front Turn Light

Refer to 5.10 Headlight Assy of 05 chapter.

#### Installation

Reverse the removal procedures for installation.

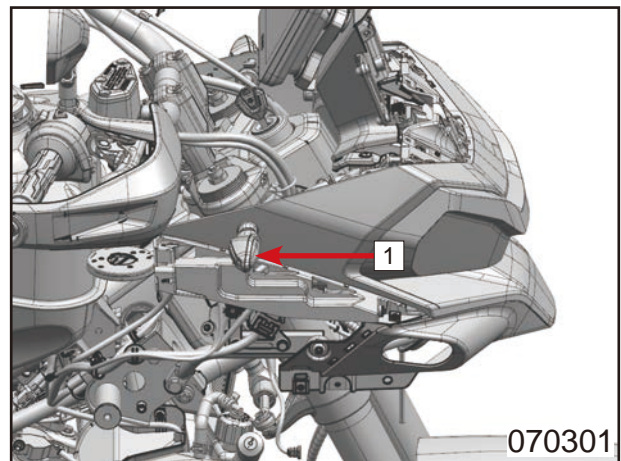

## Rear Turn Light

Remove bolts **1**.

Remove rear fender **2** and rear turn lights.

Unplug connectors.

#### Installation

Reverse the removal procedures for installation.

**NOTE: The turn lights are consisted of LED lights. When the light damages, replace the whole set.**

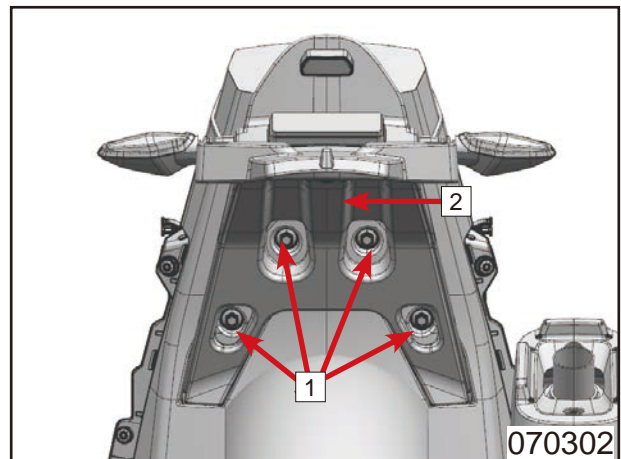

## 7.4 Tail Light/Brake Light

Remove screws **1**.

Remove bolt **2**.

Remove tail light **3**.

Remove inner hex bolts **3** if necessary. Shake frame skid plate to leave space for screws.

#### Installation

Reverse the removal procedures for installation.

**NOTE: The tail light is consisted of LED lights. When the light damages, replace the whole set.**

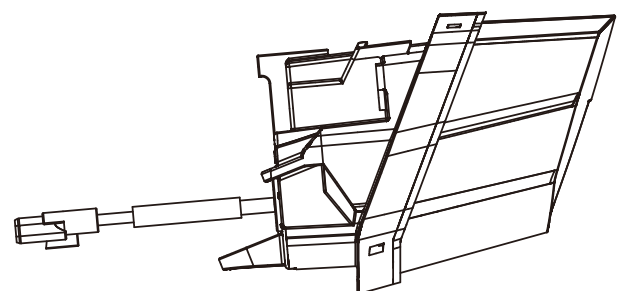
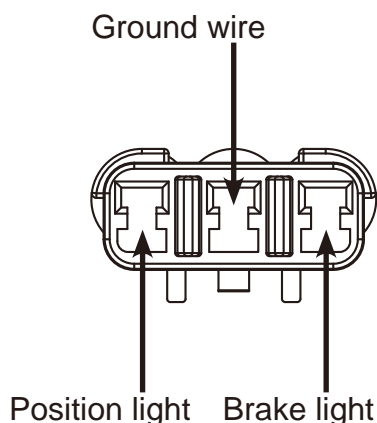
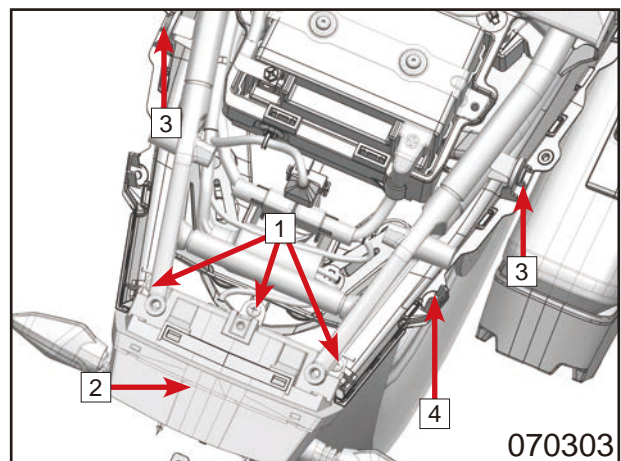

© CFMOTO Powersports, Inc. This manual is subject to all applicable copyright laws. Reproduction or duplication in any form, whole or in part, is strictly prohibited.

## 7.5 Dashboard

Refer to 5.9 Dashboard of 05 chapter.

Remove bolt<sup>1</sup>;

Disconnect the dashboard from the main cable connection light connector<sup>2</sup>;

Remove dashboard<sup>3</sup>.

### Installation

Reverse the removal procedures for installation.

PIN	Item	Function
1	Power +	12V continuous power
5	Keypad 1	UP/LEFT
6	Keypad 2	DOWN/RIGHT
7	Keypad 3	OK
8	Keypad 4	Back
12	Keyless-go system indicator	Offer 12V power signal to light up indicator
14	Power lock switch signal	12V power
22	Ground	Signal ground
23	K-line(reserved)	
24	CAN_H	Speed signal, RPM signal, gear signal, turn signal, position light signal, high-beam signal, fog light signal, oil level signal, oil pressure signal, ABS signal, EFI signal, stop switch
25	CAN_L	
26	Power ground	GND

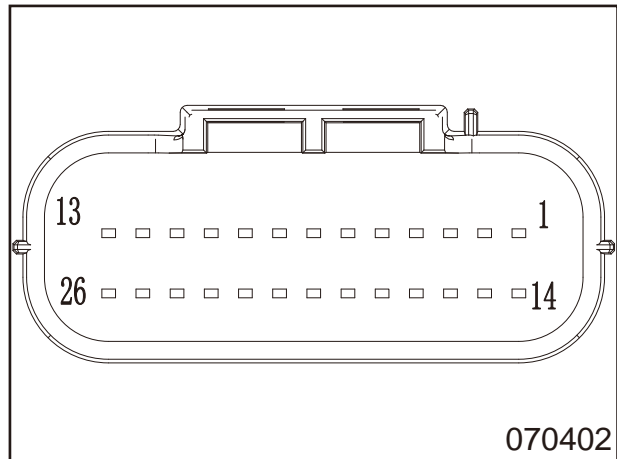
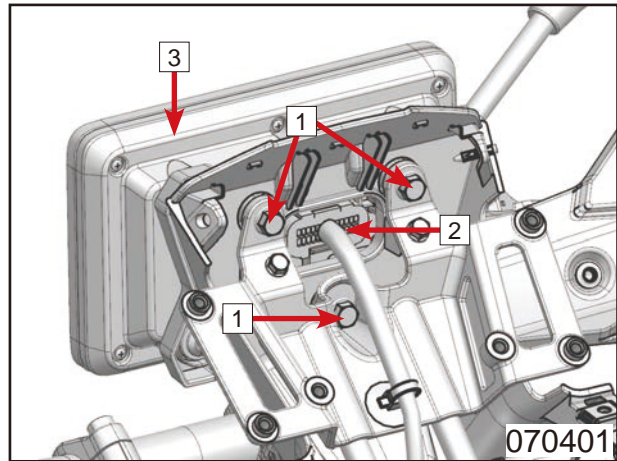

# 07 Lights, Dashboard and Switches

## 7.5.1 Dashboard(IMM)

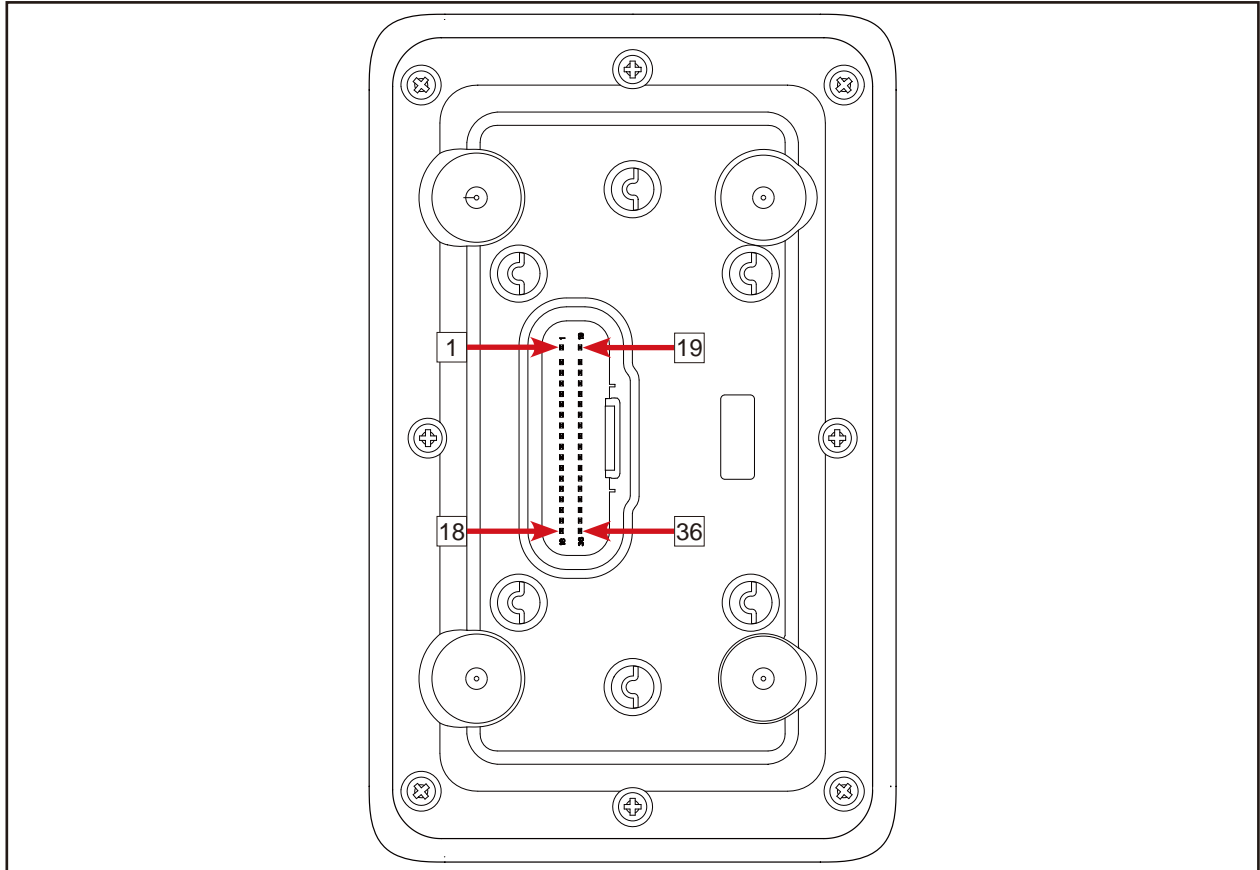

PIN	Function	Description
1	Power Negative	Power GND
2	Brake Failure Signal	Low Level Signal (Reserved)
3	Key: Up	Low Level Signal
4	EFI Indicator Signal	Low Level Signal (Reserved)
5	Key: Down	Low Level Signal
6	Mode Switch Signal	Low Level Signal
7	Key: Return	Low Level Signal
8	Key: Confirm	Low Level Signal
9	LH Turn Indicator Signal	High Level Signal (Reserved)
10	RH Turn Indicator Signal	High Level Signal (Reserved)
11	Motor 4WD Lock Signal	Low Level Signal (Reserved)
12	Switch 2WD Signal	Low Level Signal (Reserved)
13	N Gear	Low Level Signal (Reserved)
14	Electric Door Lock	High Level Signal
15	CAN-H	CAN-H CAN
16	CAN-L	CAN-L CAN
17	Switch 4WD Lock Signal	Low Level Signal (Reserved)
18	Fuel Signal	Resistance Signal
19	Power Positive	Power +

© CFMOTO Powersports, Inc. This manual is subject to all applicable copyright laws. Reproduction or duplication in any form, whole or in part, is strictly prohibited.





© CFMOTO Powersports, Inc. This manual is subject to all applicable copyright laws. Reproduction or duplication in any form, whole or in part, is strictly prohibited.

PIN	Function	Description
20	Seat Sensor Signal	Low Level Signal (Reserved)
21	Motor 2WD Signal	Low Level Signal (Reserved)
22	Motor 4WD Signal	Low Level Signal (Reserved)
23	Position Indicator Signal	High Level Signal (Reserved)
24	High-beam Indicator Signal	High Level Signal (Reserved)
25	Oil Pressure Indicator Signal	Low Level Signal (Reserved)
26	Handlebar Switch Fn Key	Low Level Signal
27	Steering Power Fault Indicator Signal	Low Level Signal (Reserved)
28	L Gear	Low Level Signal (Reserved)
29	H Gear	Low Level Signal (Reserved)
30	P Gear	Low Level Signal (Reserved)
31	R Gear	Low Level Signal (Reserved)
32	Buzzer+	Buzzer Positive (Reserved)
33	Buzzer-	Buzzer Negative (Reserved)
34	Parking Signal (Hand Brake)	Low Level Signal (Reserved)
35	Speed Signal	Voltage Pulse Signal (Reserved)
36	Keyless Indicator Signal	High Level Signal (Reserved)

## 7.6 Ignition Switch

### Inspection

Pull out the connectors between ignition switch 1 and main cable to check its performance.

Ignition switch			
Action/Color	R	B	Occlusion reaches out or not
			No
			No
			Yes

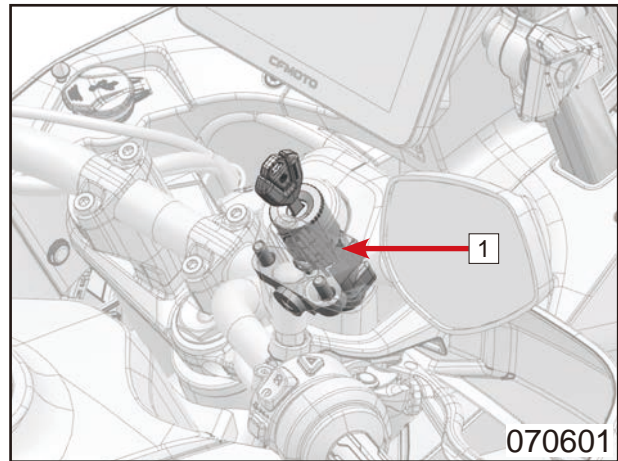

## 7.7 Front Brake Light Switch

Pull out the connectors between front brake light switch 1 and main cable to check its performance.

- 1) Grip front brake lever, the brake light is on.
- 2) Loosen front brake lever, the brake light is off.

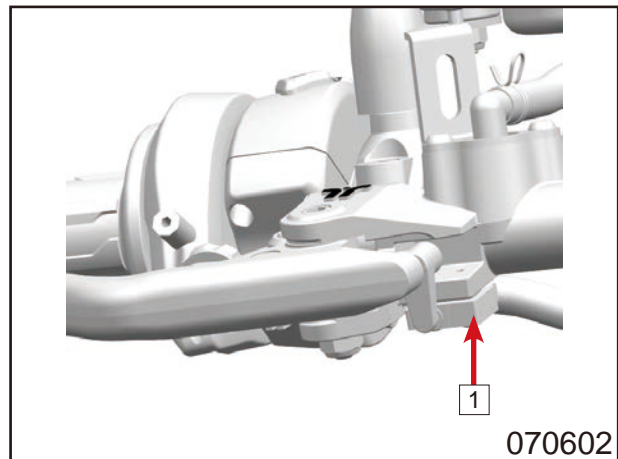

# 07 Lights, Dashboard and Switches

## 7.8 LH Handlebar Switch(Status 1)

Unplug the connectors between LH handlebar switch and main cable to check its performance.

Menu Button A1			
Function \ Color	G/B	Gr/W	W/G
△	●	●	
▽	●		●

Menu Button B2			
Function \ Color	G/B	Y/B	W/Y
↶	●	●	
SET	●	●	●

Turn switch 3				
Function \ Color	O	G/B	B/W	Sb
↶	●	●		
OFF		●	●	
↷		●	●	●

Horn switch 4		
Function \ Color	Lg	G/B
📢	●	●

Fog light switch 5		
Function \ Color	Y/L	G/B
ON	●	●
OFF		

Dimmer switch 6		
Function \ Color	L/Gr	G/B
☰	●	●
☷		
☷	●	●

Cruise switch 7				
	620 Ω ±2%	750 Ω ±2%	1500 Ω ±2%	6200 Ω ±2%
Y/W	□	□	□	□
R/W	○	○	○	○
	OFF/ON	SET/-	RES/+	

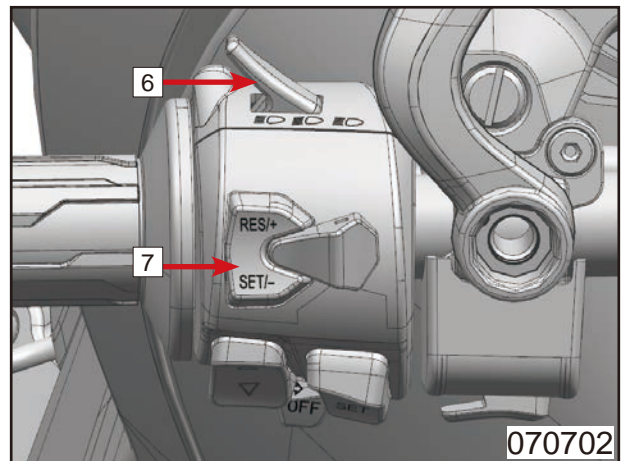
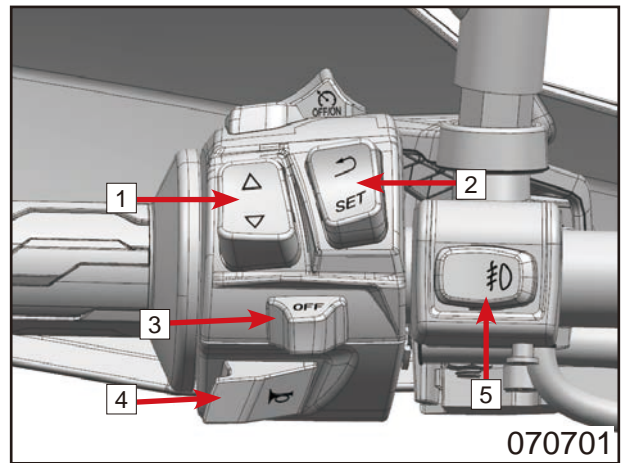

© CFMOTO Powersports, Inc. This manual is subject to all applicable copyright laws. Reproduction or duplication in any form, whole or in part, is strictly prohibited.

## 7.9 LH Handlebar Switch(Status 2)

Disconnect the connectors between LH handlebar switch cable and main cable to check the performance of each switch.

© CFMOTO Powersports, Inc. This manual is subject to all applicable copyright laws. Reproduction or duplication in any form, whole or in part, is strictly prohibited.

Fn switch 1			
function \ color	Y/G	G	BR
Fn	●	●	●



Custom switch 2			
function \ color	R	G	BR
*	●	●	●



Menu switch 3						
function \ color	G	B/W	B/L	V	L/W	BR
▲	●	●				●
▶	●		●			●
◀	●			●		●
▼	●				●	●



Voice switch 4			
function \ color	Y	G	BR
🗣️	●	●	●



Steering switch 5				
function \ color	O	G	GR	SB
↶	●	●		
OFF		●	●	
↷		●	●	●

Horn switch 6			
function \ color	LG	G	BR
📢	●	●	●



Cruise switch 7		
function \ color	BR	G
+RES	●	●
SET-	●	●

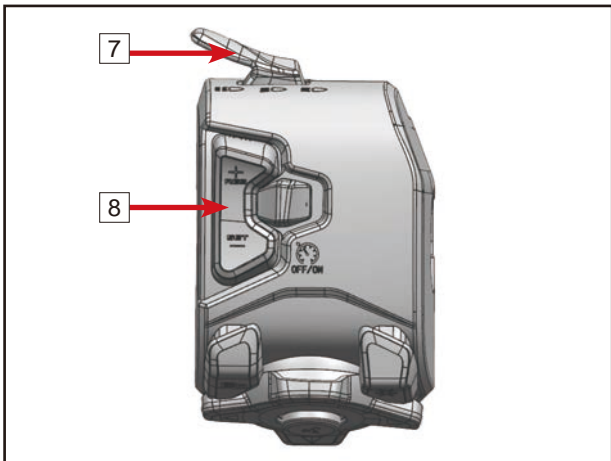
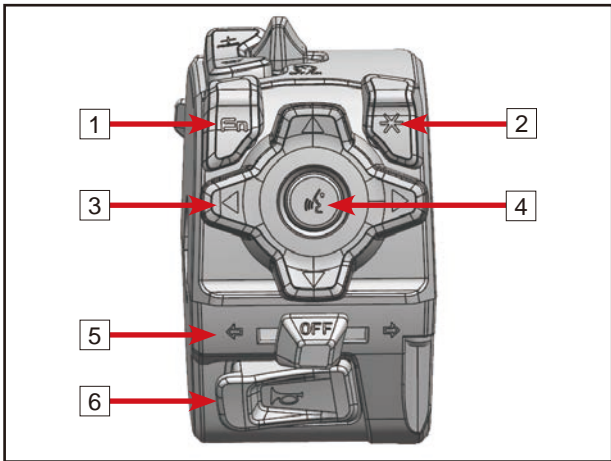
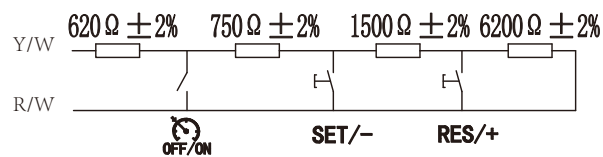

# 07 Lights, Dashboard and Switches

## 7.10 RH Handlebar Switch(Status 1)

Unplug the connectors between RH handlebar switch and main cable to check its performance.

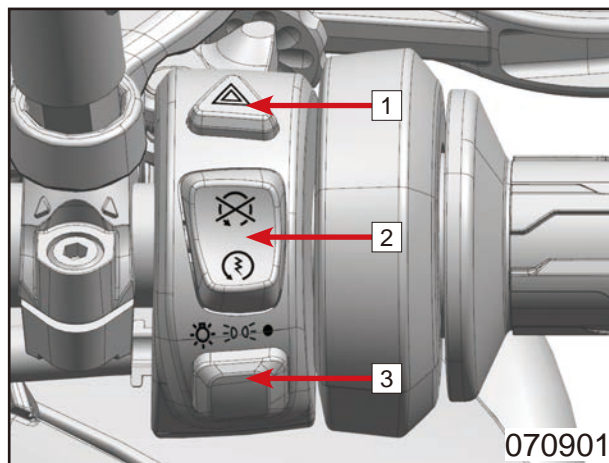

Hazard switch 1		
Function	Color	
	Lr	G/B
Start switch 2		
Function	Color	
	G/R	Y/W
Stop switch 2		
Function	Color	
	B/Br	G/B
Illumination switch 3		
Function	Color	
	L/W	G/W

© CFMOTO Powersports, Inc. This manual is subject to all applicable copyright laws. Reproduction or duplication in any form, whole or in part, is strictly prohibited.

## 7.11 RH Handlebar Switch(Status 2)

Unplug the connectors between RH handlebar switch and main cable to check its performance.

© CFMOTO Powersports, Inc. This manual is subject to all applicable copyright laws. Reproduction or duplication in any form, whole or in part, is strictly prohibited.

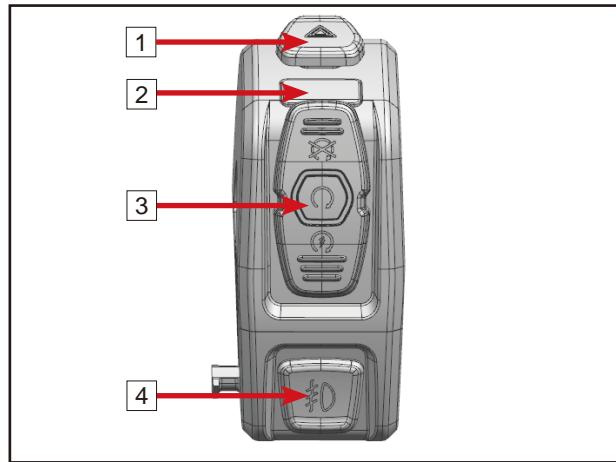
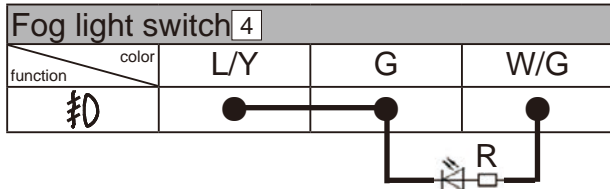
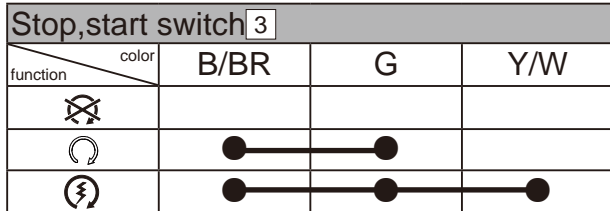
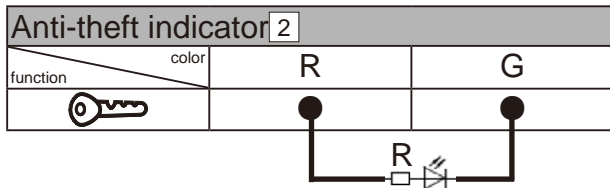
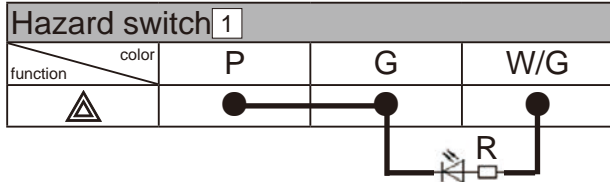

## 7.12 Fog Light

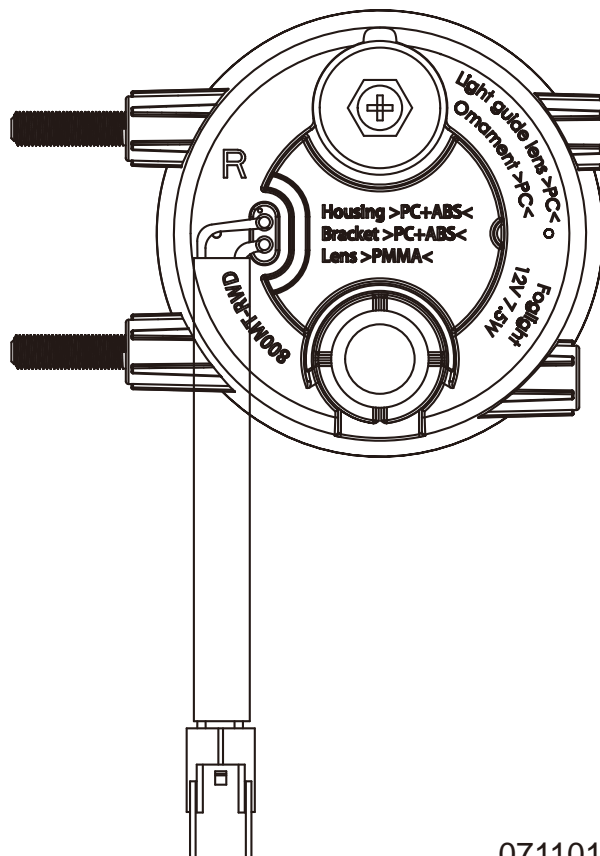
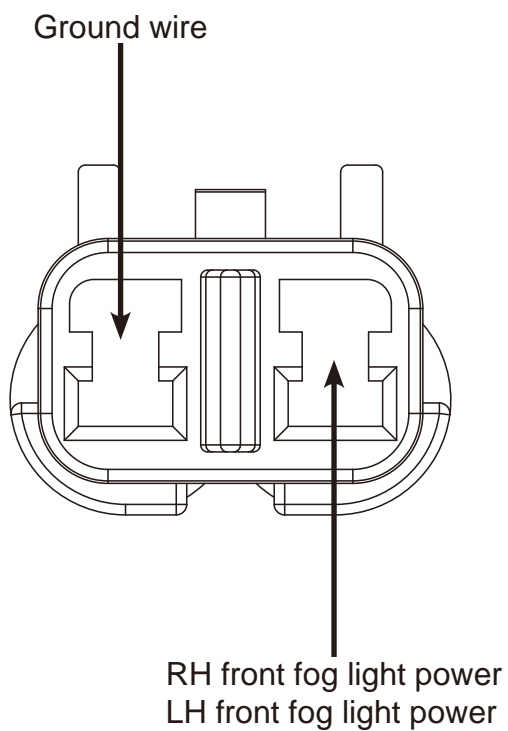

071101

## 7.13 Horn

Unplug horn connector. Connect with 12V battery to check if the horn works well and the sound is loud and clear. Otherwise, replace with a new horn.

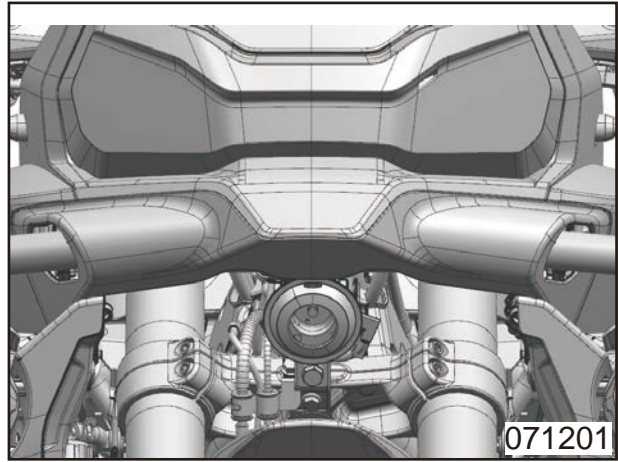

## 7.14 Fuel Level Sensor

Remove four nuts [1].

Remove fuel level sensor [2].

**⚠ CAUTION: Remove fuel level sensor slowly, in case it deforms.**

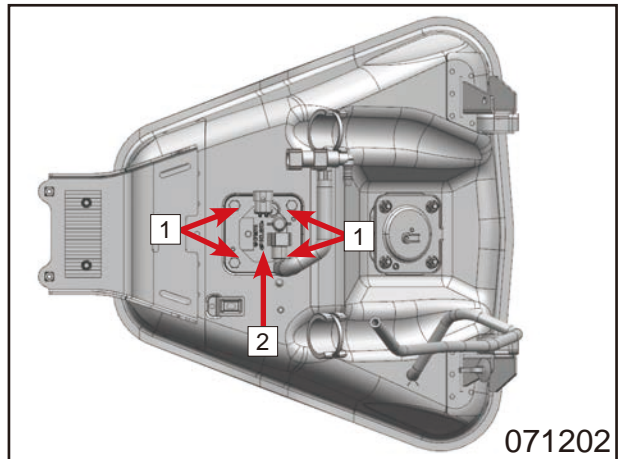

### Inspection

Inspect fuel level sensor seal ring [3] for deformation, damage or hardening. Replace if it does.

Check the electrical resistance of the oil level sensor at high and low poles.

### Resistance:

High:  $10\Omega \pm 2\Omega$

Low:  $100\Omega \pm 2\Omega$

Connect fuel level sensor and main cable. Turn on ignition switch, the floater of fuel level sensor swings up and down slowly. See the fuel gauge [4] pointer on dashboard.

If the pointer can not reach F or E, it means the fuel gauge is not qualified, replace a new one.

If the pointer swings unsteadily, it means the fuel gauge is not qualified, replace a new one.

### Installation

Reverse the removal procedures for installation.

**⚠ CAUTION: Check leakage after fuel level sensor installation.**

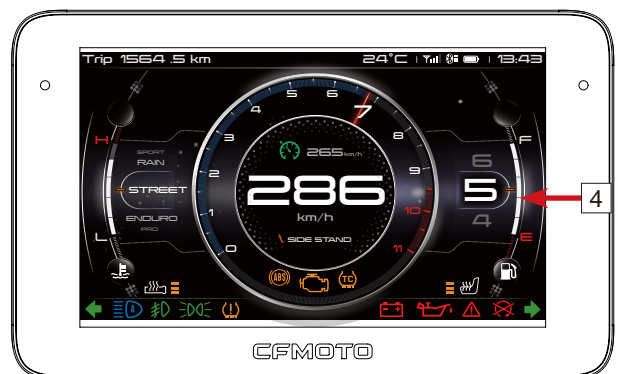
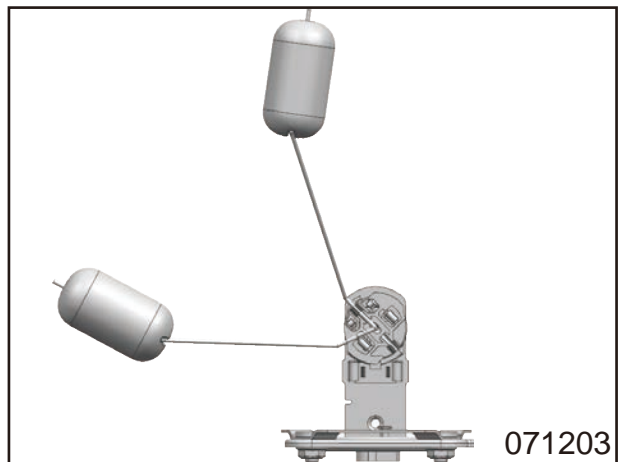

## 7.15 Battery

### **⚠ WARNING:**

1. Even if the battery is not used, it also loses power every day.
2. Charging condition and charging mode are very important for the service life of the battery. Using high charging current will have a negative impact on the service life.
3. If the charging current, charging voltage and charging time are exceeded, the battery will be damaged.
4. If the battery becomes empty due to repeated start of the vehicle, it needs to be charged immediately.
5. When the battery is stored in the discharge condition for a long time, deep discharge and sulfuric acid salination will occur, which damages the battery.
6. The battery does not need to be maintained, which means the acid level does not need to be checked.
7. Battery wires are not allowed to be removed while the engine is working.
8. It is forbidden to puncture the wire to test the input/output electrical signals.
9. Establish the awareness of environmental protection and effective disposal of waste generated during maintenance.

### **Removal**

Remove rear seat.

Remove battery negative wire lock bolt **1**.

Remove negative wire from the battery.

Remove battery positive wire lock bolt **2**.

Remove positive wire from the battery.

Remove battery bracket **3**.

Remove battery **4**.

**⚠ CAUTION: Negative wire must be removed first. Otherwise, it will cause battery short circuit.**

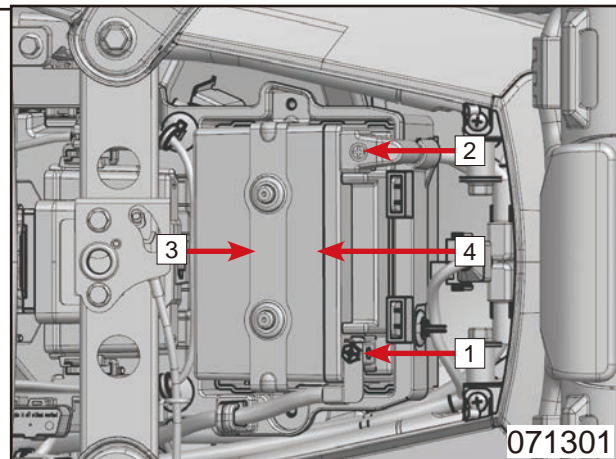

### **Installation**

Reverse the removal procedures for installation.

## Charge

Shut down all the electrical devices and engine.

Remove battery.

Connect charger and battery.

After charging, remove the charger from the battery.

**NOTE: CFMOTO recommends for vehicles not used within 30 days (battery remains in the vehicle) to charge the battery monthly or keep the battery connected to a trickle charger (battery maintainer).**

### Charging Voltage Inspection

The battery has proper performance and is fully charged.

Start the vehicle and measure the voltage.

Measuring point is positive pole (+), the other measuring point connects ground (-).

Charging Voltage	
5000rpm	13.5V~15.0V

### If less than specification:

Inspect the connectors between engine and regulator.

Inspect the connectors between regulator and cables.

Inspect engine electronic winding.

### If more than specification:

Replace regulator.

## 7.16 Vehicle T-BOX

T-BOX is tied up by rubber strap on T-Box bracket. T-Box bracket is welded on headlight bracket.

Remove T-BOX 1.

Inspect connectors for performance.

### Installation

Reverse the removal procedures for installation.

## 7.17 Ground Wire

Ground point locates under main seat and rear frame behind air filter.

### Inspection

Shut down engine and all electrical parts.

Inspect ground wire.

Inspect bolt 1 for looseness.

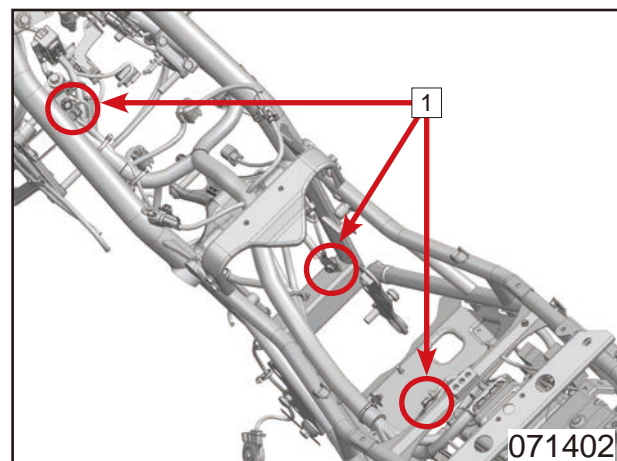
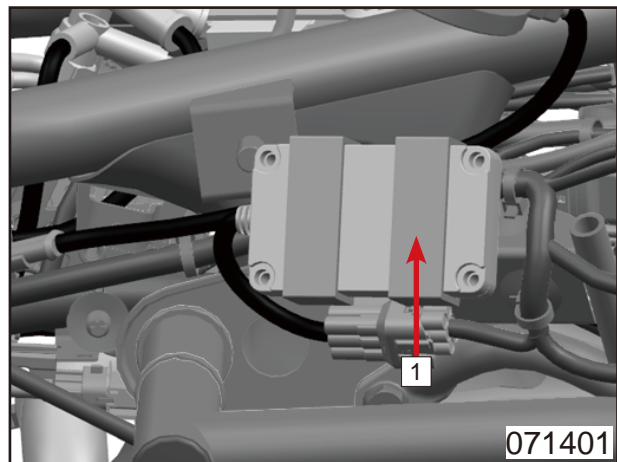

## 7.18 Start Engine Stop Control Unit

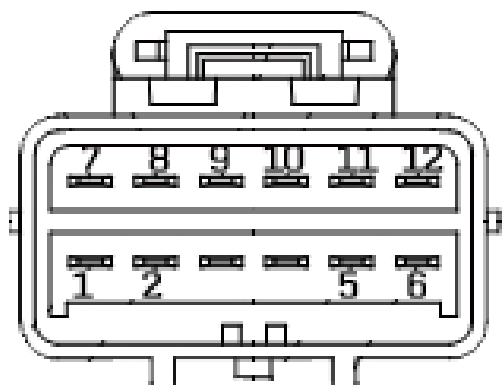

PIN	Function
1	Continuous power
2	Ground
5	Lock/Unlock button (input)
6	Lock input signal
7	Output T15
8	LED output signal
9	CAN_H
10	CAN_L
11	Fuel tank cap power
12	Fuel tank cap signal input

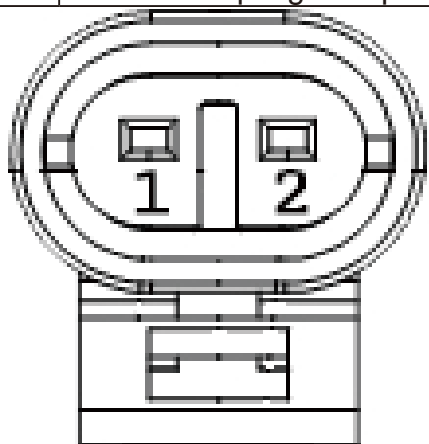

PIN	Function
1	Input/Output
2	Input/Output

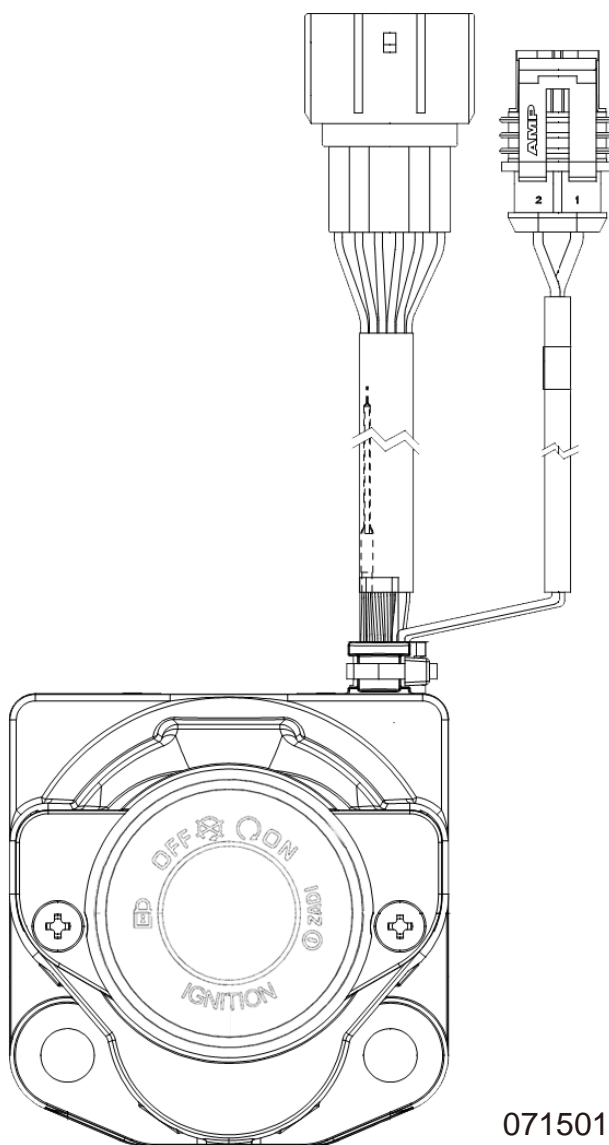

071501

## 7.19 Headlight Controller

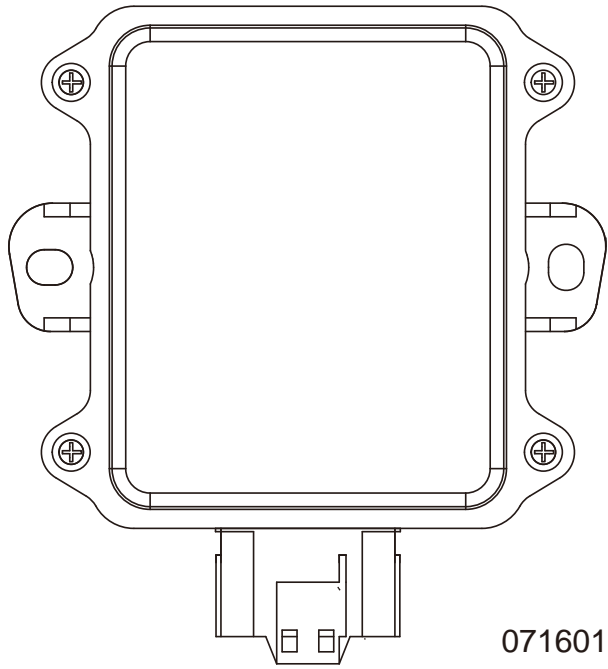
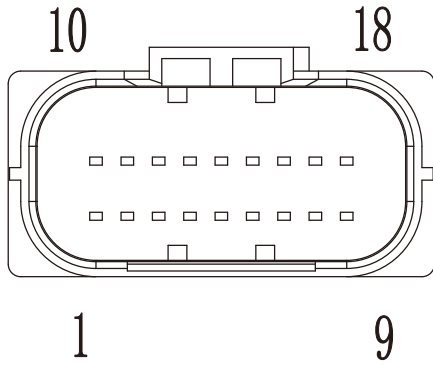

071601

PIN	Function
1	High-beam +
2	High-beam -
3	Low-beam +
4	Low-beam -
5	Front position light +
6	/
7	Front position light -
8	Fog light switch
9	CAN_H
10	LH fog light output
11	RH fog light output
12	Rear position light output
13	Ignition lock power
14	Ground
15	/
16	Illumination switch
17	High-beam switch
18	CAN_L

### Diagram

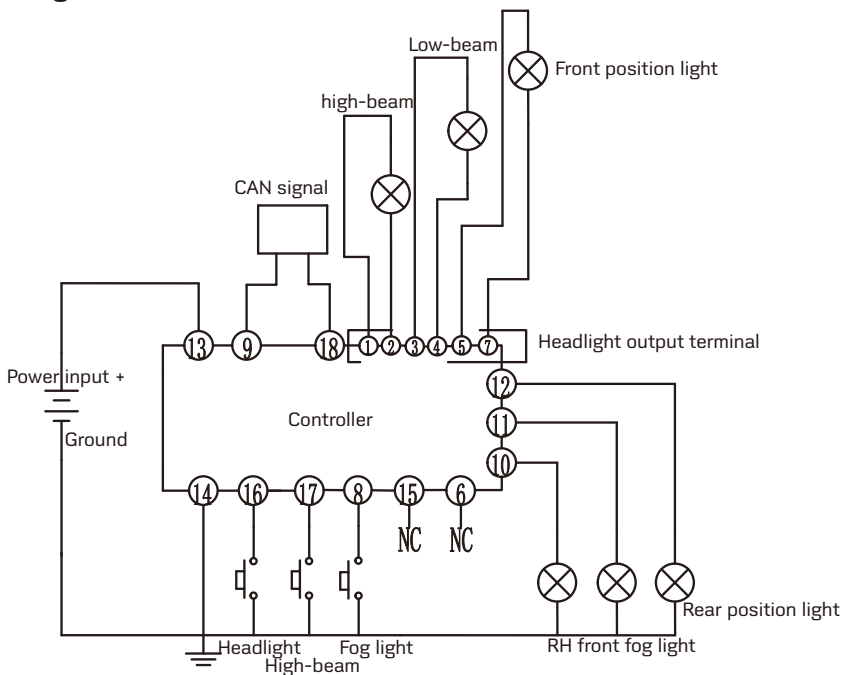

© CFMOTO Powersports, Inc. This manual is subject to all applicable copyright laws. Reproduction or duplication in any form, whole or in part, is strictly prohibited.

# 07 Lights, Dashboard and Switches

## 7.20 Headlight Cable

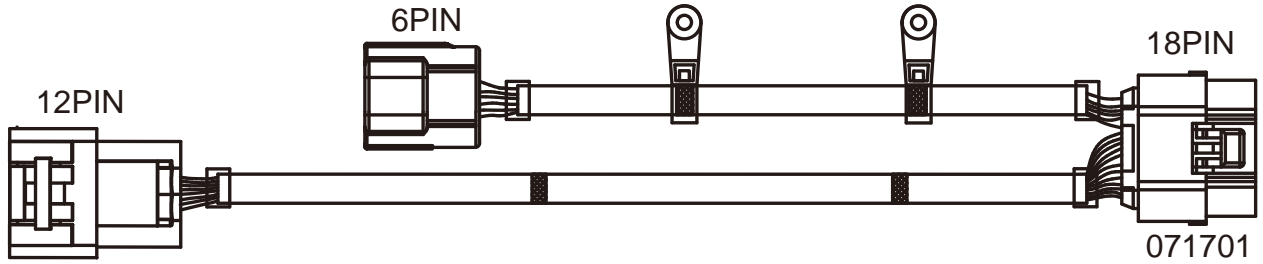

6PIN Connector	
PIN	Function
1	High-beam +
2	High-beam -
3	Low-beam +
4	Low-beam -
5	Front position light +
6	Front position light -

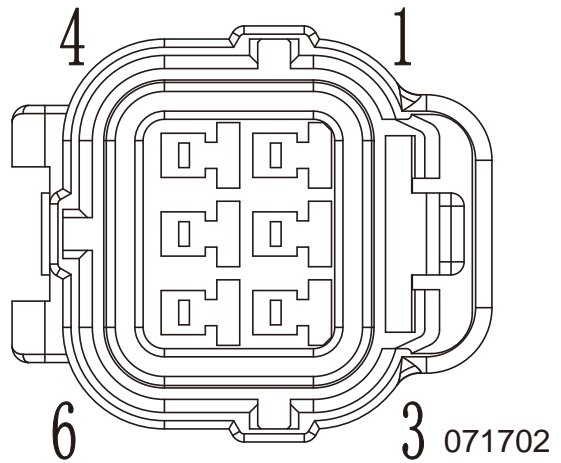

12-PIN Connector	
PIN	Function
1	LH fog light output
2	CAN_L
3	CAN_H
4	Ignition lock power
5	Fog light switch
6	Ground
7	Illumination switch
8	High-beam switch
9	Rear position light output
10	RH fog light output
11	/
12	/

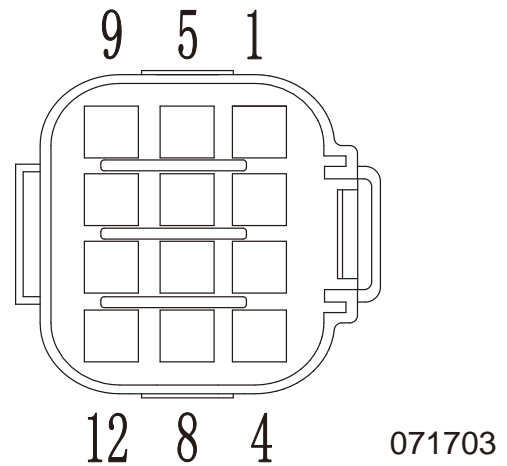

© CFMOTO Powersports, Inc. This manual is subject to all applicable copyright laws. Reproduction or duplication in any form, whole or in part, is strictly prohibited.

© CFMOTO Powersports, Inc. This manual is subject to all applicable copyright laws. Reproduction or duplication in any form, whole or in part, is strictly prohibited.

18PINConnector	
PIN	Function
1	High-beam +
2	High-beam -
3	Low-beam +
4	Low-beam -
5	Front position light +
6	/
7	Front position light -
8	Fog light switch
9	CAN_H
10	LH fog light output
11	RH fog light output
12	Rear position light output
13	Ignition lock power
14	Ground
15	/
16	Illumination switch
17	High-beam switch
18	CAN_L

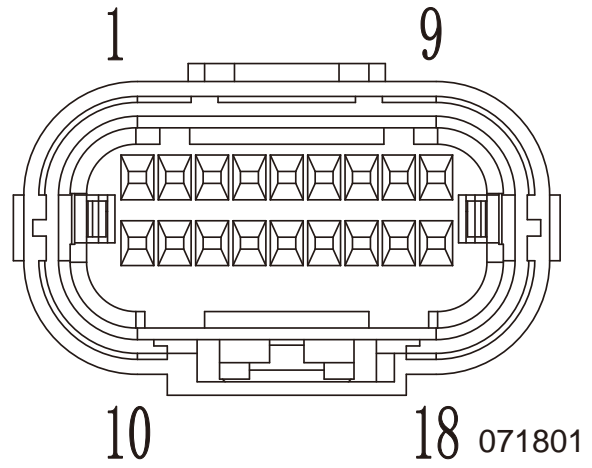

## 07 Lights, Dashboard and Switches

### 7.21 Radar Sensor (Backward - Short-range ranging sensor)

Working frequency range: 76GHz~77GHz

Speed measuring range: -110~+50 m/s。

Detection distance: 0.5m~100m。

Detection zone: 150° (horizontal) × 20° (pitch)

Working voltage: 9V~16V DC;

Working current: 300mA

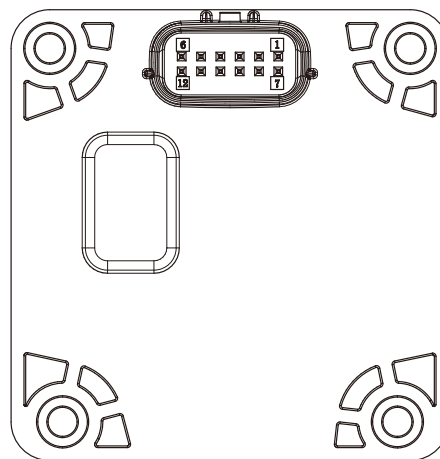

Storage temperature: -40°C~95°C;

Working temperature: -40°C~85°C

Pin	Function	Pin definition	Current (mA)
1	NC	NULL	/
2	POS1	address wire	1
3	CAN1_L	vehicle CAN1_L	20
4	CAN2_L	private CAN2_L	20
5	LED1+	to LH alarm LED	20
6	Power	power input (DC12+)	250
7	NC	NULL	/
8	GND	GND	250
9	CAN1_H	vehicle CAN1_H	20
10	CAN2_H	private CAN2_H	20
11	LED2+	to RH alarm LED	20
12	BUZZER+	to buzzer	20

## 7.22 Body Control Module

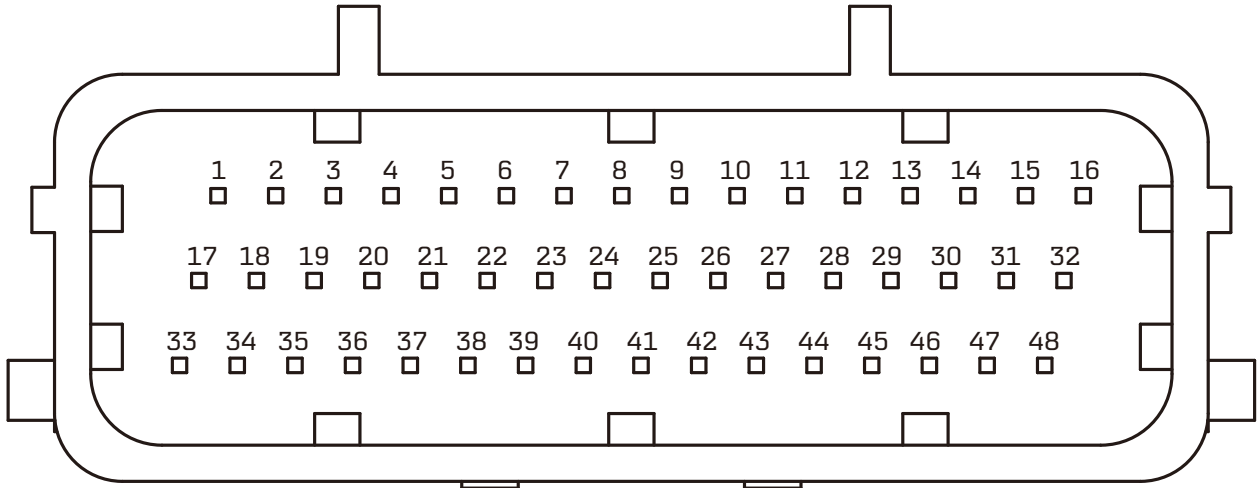

PIN	Function	Remark	IN/OUT/COM/GND/ SUPPLY
1	Rear RH turn light		OUT
2	Start relay		OUT
3	Front RH turn light		OUT
4	Hazard system	Reserved	IN
5	Offer 5V power to sensor	Reserved	SUPPLY
6	Horn switch	Ground	IN
7	Oil pressure switch	Ground	IN
8	Outer sensor ground		GND
9	RH turn switch	Ground	IN
10	Back-up sensor	Reserved	IN
11	Standard_CAN_L		COM
12	Handlebar heating		OUT
13	Standard_CAN_H		COM
14	Driver heated seat power		OUT
15	Horn		OUT
16	Power to BCM(30A)		SUPPLY
17	Power to ECU	ECU PIN35	OUT
18	Rear LH turn light		OUT
19	Front LH turn light		OUT
20	Ignition switch		IN
21	Oil temp. sensor	Reserved	IN
22	LH turn switch	Ground	IN
23	Rear brake switch 1	Reserved	IN
24	Fuel pump signal	ECU PIN41	IN
25	Rear brake switch 2	Reserved	IN
26	Stop switch	Ground	IN
27	Hazard switch	Ground	IN
28	Fan 1 ground		GND
29	Message_CAN_H		COM
30	Driver heated seat ground		GND
31	Rear brake light	Reserved	OUT

## 07 Lights, Dashboard and Switches

32	Power to BCM(30A)		SUPPLY
33	Power to BCM(30A)		SUPPLY
34	Power to outer controller	K15 power	OUT
35	Passager heated seat	Reserved	OUT
36	Fan 2 power	Reserved	OUT
37	Fuel level sensor		IN
38	Oil level switch	Reserved	IN
39	Turn reset switch	Ground	IN
40	Vehicle ground		GND
41	Front brake switch	Reserved	IN
42	Vehicle ground		GND
43	Passager seat switch	Reserved	IN
44	Fan 1		OUT
45	Message_CAN_L		COM
46	Fuel pump control		OUT
47	Start signal	ECU PIN58	IN
48	Power to BCM(30A)		SUPPLY

### 7.22.1 BCM Fault and Detection

DTC Code	DTC Display	DTC Meaning	Fault Manifestation	Detection Method
B104019	0x902019	Fan control overcurrent	The fan does not turn when the water temperature is too high	Check whether the fan is blocked or the cable harness of control fan is short-circuited or the fan is short-circuited
P212817	0x902024	Electronic throttle pedal position sensor signal 2 voltage too high	Only add to 5000	Test the gas pedal signal voltage 2 Whether the voltage is output
B102013	0x902013	LH turn light circuit open	Another turn signal on the same side blinks rapidly	Check the turn light output voltage and current (5-11V) (30ma). Check that the harness from the BCM control end to the LH turn light may be disconnected or the light is broken
B100064	0x900064	Ignition switch signals unreliable or incoherent	Fail to fire	Check the ignition signal voltage and if the ignition switch is abnormal
B100211	0x900211	Fuel level sensor short to the ground	Fuel level icon blinks quickly 2Hz	Fuel level sensor open circuit inside or the sensor signal and the BCM input harness short to the ground
B100215	0x900215	Fuel level sensor open, short to the power supply voltage or the vehicle power supply voltage	Fuel level icon blinks quickly 2Hz	Fuel level sensor open circuit inside or the sensor signal and the BCM input harness short to the power supply

© CFMOTO Powersports, Inc. This manual is subject to all applicable copyright laws. Reproduction or duplication in any form, whole or in part, is strictly prohibited.

B100416	0x900416	Internal fuel level sensor 5V power signal overvoltage	Cannot display fuel level	Check BCM fuel level sensor output voltage 5V
B100417	0x900417	Internal fuel level sensor 5V power signal overvoltage	Cannot display fuel level	Check BCM fuel level sensor output voltage 5V
B111716	0x911716	Vehicle power supply voltage below threshold	Vehicle power failure	Battery voltage too low
B111717	0x911717	Vehicle power supply voltage below threshold	Vehicle power failure	Battery voltage too high
B100911	0x900911	Ignition module power short to the ground	ECU does not work, oil pump does not self-check	Measure BCM ignition output signal 47 pin short to ground
B100912	0x900912	Ignition module power supply shorted the power supply voltage or the vehicle power supply voltage	ECU cannot be powered off	Measure BCM ignition output signal 47 pin short to ground
B100919	0x900919	Ignition module power overcurrent	ECU does not work properly	A multimeter measures the current. A large current jump indicates that the controller is faulty
B101011	0x901011	ECU short circuit to ground	Headlight controller, ABS, dashboard not working	The wake power harness of ECU short to the ground
B101012	0x901012	ECU power supply shorted the power supply voltage or the vehicle power supply voltage	Headlight controller, ABS, dashboard cannot be closed by key	Unplug to measure the resistance of power supply and ground
B101019	0x901019	ECU power overcurrent	Headlight controller, ABS, dashboard not work properly	Measure whether the electrical current is too low
B101511	0x901511	Horn control short to the ground	The horn doesn't sound	Check whether the fuse and BCM15 pin control cable are broken or not
B101513	0x901513	Horn control open circuit	The horn doesn't sound	Replace the horn or adjust the horn bolts
B101515	0x901515	Horn control short to the power supply voltage or the vehicle power supply voltage	Honk all the time	Replace the horn or adjust the horn bolts
B101516	0x901516	Horn control undervoltage	The horn does not sound, or the sound is abnormal	Series horn control line to measure current (replace BCM)

## 07 Lights, Dashboard and Switches

B101517	0x901517	Horn control undervoltage	The horn does not sound, or the sound is abnormal	"Too much current causes the horn to be abnormal, measure if the control voltage is too high (replace BCM)"
B101519	0x901519	Horn control overcurrent	The horn does not sound, or the sound is abnormal	Series horn control line to measure current (replace BCM)
B101598	0x901598	Horn control overtemperature	The horn does not sound, or the sound is abnormal	Measure the control voltage of the BCM15 pin and replace the BCM after determining a sudden high current
B101611	0x901611	Heating grip control short circuit to ground	Heating grip doesn't work	Check if the heating harness is broken or short circuit with the ground (replace the heating handle)
B101613	0x901613	Heating grip control open circuit	Heating grip doesn't work	Check the plug for virtual leakage and measure whether the heating handle circuit is normal
B101615	0x901615	Heating grip control short circuit to the power supply voltage or the vehicle power supply voltage	Heating grip still work	Measure whether the control harness is short-circuited to the power supply and whether the harness is broken
B101616	0x901616	H e a t i n g grip control underpressure	Heating grip does not work properly or does not work	Check that the battery voltage or heating grip power supply is below 9V
B101617	0x901617	H e a t i n g grip control overpressure	Heating grip does not work properly or does not work	Check that the battery voltage or heating grip power supply is above 16V
B101619	0x901619	Heating grip control overflow	Heating grip does not work properly or does not work	Short circuit inside heating grip or short circuit outside harness
B101698	0x901698	Heat grip control overtemperature	Heating grip does not work properly or does not work	Short circuit inside heating grip or short circuit outside harness
B101911	0x901911	Starter motor control short to the ground	The starting relay cannot be closed	Check whether the cable of starter motor short to the ground
B101912	0x901912	Starter motor controls short to the power supply voltage or the vehicle power supply voltage	Automatic ignition on the electric bottle	Check whether the starter motor cable short to the power supply
B101913	0x901913	Starter motor control open circuit	Starter relay cannot be closed	"Check whether the start button switch is missing, and check whether the BCM47 start signal voltage is normal"

© CFMOTO Powersports, Inc. This manual is subject to all applicable copyright laws. Reproduction or duplication in any form, whole or in part, is strictly prohibited.

B101919	0x901919	Starting motor controls overcurrent	The starting relay is burned out or not working properly	Check to see if the underside of the tank is in place
B102011	0x902011	LH front turn light short to the ground	The turn signal doesn't work	Check whether the BCM19 and 40PIN outputs are normal. Replace the turn signal if it does.
B102013	0x902013	LH front turn light circuit open	The turn signal doesn't work or blinks too fast	Check whether 19PIN of the turn signal plug and BCM output plug are virtual connections
B102012	0x902012	LH front turn light short to the power supply voltage or the vehicle power supply voltage	The turn signal doesn't work	Measure the output voltage around 5-8V. If not, replace the turn light or BCM.
B102019	0x902019	LH front turn light overcurrent	The turn signal doesn't work	Measure whether the current of the turn light is stable or not, and replace the turn light.
B102111	0x902111	RH front turn light short to the ground	The turn signal doesn't work	Replace the turn light.
B102113	0x902113	RH front turn light circuit open	The turn signal doesn't work	Check the turn light plug and BCM3 PIN for virtual connections
B102112	0x902112	RH front turn light short to the power supply voltage or the vehicle power supply voltage	The turn signal doesn't work	Replace the turn light after checking that the plug is normal.
B102119	0x902119	RH front turn light overcurrent	The turn signal doesn't work	Replace turn light
B102211	0x902211	LH rear turn light short to the ground	The turn signal doesn't work	Check the plug for misconnections or short connections
B102213	0x902213	LH rear turn light circuit open	The turn signal doesn't work	Check the turn light plug and BCM18 PIN for virtual connections
B102212	0x902212	LH rear turn light short to the power supply voltage or the vehicle power supply voltage	The turn signal doesn't work	Measure the resistance and check the LH rear turn light plug or harness
B102219	0x902219	LH rear turn light overcurrent	The turn signal doesn't work	Replace turn light
B102311	0x902311	RH rear turn light short to the ground	The turn signal doesn't work	Measure the resistance and check the RH rear turn light plug or harness
B102313	0x902313	RH rear turn light circuit open	The turn signal doesn't work	Check the turn signal plug and BCM1 PIN for virtual connections

## 07 Lights, Dashboard and Switches

B102312	0x902312	RH rear turn light short to the power supply voltage or the vehicle power supply voltage	The turn signal doesn't work	Measure the resistance and check the rear RH turn signal plug or harness
B102319	0x902319	Rear RH turn light overcurrent	The turn signal doesn't work	Replace turn light
B102716	0x902716	Downstream main relay battery voltage undervoltage	The screen does not light up or does not start	Measure the battery voltage
U007388	0xC07388	CAN bus - harness short circuit or hardware problem	Dashboard fault and could not be started	Measure CAN bus terminal resistance.
U012187	0xC12187	CAN communication - CAN harness electrical problems or ABS failures	CAN communication abnormal	"Check whether the OBD pins are withdrawn and whether the CAN cables of the ABS module are virtual connected. Check whether the terminal resistance if qualified, replace the ABS controller."
U015587	0xC15587	CAN communication - CAN harness electrical problems or dashboard failures	CAN communication abnormal	"Check whether the OBD pins are withdrawn and then measure whether the terminal resistance of the meter is 120 ohMs and whether the voltage of CAN H and CAN L is equal to 5V"
U010087	0xC10087	CAN communication - CAN harness electrical problem or engine control unit failure	CAN communication abnormal	Check the OBD pin for withdrawal and measure the terminal resistance.
U171608	0xD71608	CAN communication - CAN harness electrical problems or ABS failures	CAN communication abnormal	"Check whether the OBD pins are withdrawn and whether the CAN cables of the ABS module are virtual connected. Check whether the terminal resistance if qualified, replace the ABS controller."
U171708	0xD71708	CAN communication - CAN harness electrical problems or dashboard failures	CAN communication abnormal	"Check whether the OBD pin is withdrawn and whether the CAN wire of dashboard module is virtual connected. After measuring the terminal resistance, check the power supply circuit."

© CFMOTO Powersports, Inc. This manual is subject to all applicable copyright laws. Reproduction or duplication in any form, whole or in part, is strictly prohibited.

U171808	0xD71808	C A N communication - CAN harness electrical problem or engine control unit failure	C A N communication abnormal	Check the ECU's CAN voltage, resistance, and communication with BCM module
B103911	0x903911	Pump flame-out switch short to the ground	S o m e B C M functions are abnormal	BCM internal damage, replace the BCM
B103912	0x903912	Pump flame-out switch short to the power supply	S o m e B C M functions are abnormal	BCM internal damage, replace the BCM
B104011	0x904011	Fan control short to the ground	The fan does not turn when the water temperature is too high	Measure the internal resistance of fan, and measure whether the BCM44 pin and ground are smooth
B104019	0x904019	The fan control overcurrent	The fan does not turn when the water temperature is too high	The fan is blocked or short-circuited
B104111	0x904111	F u e l p u m p control short to ground	Can not start	Check the fuel pump plug or measure the resistance of fuel pump coil
B104113	0x904113	F u e l p u m p control open circuit	Can not start	Check fuel pump plug pin or missing plug
B104115	0x904115	F u e l p u m p control short to the power supply voltage or the vehicle power supply voltage	Fuel pump not work	Check pump plugs, BCM outputs and fuses
B104116	0x904116	F u e l p u m p c o n t r o l underpressure	Fuel pump not work	Measure the fuel pump coil resistance, check the fuse, or replace the hardware BCM
B104117	0x904117	F u e l p u m p c o n t r o l overpressure	Fuel pump not work	Measure the fuel pump coil resistance, check the fuse, or replace the hardware BCM
B104119	0x904119	F u e l p u m p control overflow	Fuel pump not work	Product operating current does not match output current (replace fuel pump)
B104198	0x904198	F u e l p u m p c o n t r o l overtemperature	Fuel pump not work	Measure fuel pump housing for leakage
B104213	0x904213	Fan control open circuit	The fan does not turn when the water temperature is too high	Whether the fan plug is plugged in
B104464	0x904464	T h e t u r n switch signal is unreliable or incoherent	The turn light is not working	Measure turn signal control signal (replace LH handlebar assembly)

## 07 Lights, Dashboard and Switches

B104501	0x904501	Integrated circuit U13 communication - Unstable error	Partial failure	BCM internal failure (Replace BCM directly)
B104529	0x904529	Integrated circuit U13 Communication - The device does not respond	Partial failure	BCM internal failure (Replace BCM directly)
B104581	0x904581	Integrated Circuit U13 Communication - Invalid data received	Partial failure	BCM internal failure (Replace BCM directly)
B105164	0x905164	The internal 5v power supply is faulty	Clutch switch does not work	BCM internal failure (Replace BCM directly)
B105264	0x905264	Warning switch fault	The warning function is not controlled	Check whether the warning switch is in poor contact
B105611	0x905611	Seat pad heating control command short circuit to ground	The seat is not heated	Measure whether the BCM14 pin is connected to the ground
B105619	0x905619	Seat heating control command overcurrent	The seat is always heated	Check whether the internal resistance of seat is infinitesimal or check the heating current
B105713	0x905713	Seat heating control command open circuit	The seat is not heated	Check whether the seat plug is false or missing
U010087	0XC10087	Loss of communication of ECM Engine RPM and others ECM Engine RPM and others	Network Faults	CAN bus circuit is short or open
U118287	0XD18287	Loss of communication of MMI Drive Sens Req DASH/MMI Drive Sens Req	Network Faults	CAN bus circuit is short or open
B110113	0x910113	Front turn left lamp open circuit	Actuator Faults	Wiring harness failure or the load failure.
B110111	0x910111	"Front left turn signal lamp short circuit to ground	Actuator Faults	"Wiring harness failure or the load failure.

© CFMOTO Powersports, Inc. This manual is subject to all applicable copyright laws. Reproduction or duplication in any form, whole or in part, is strictly prohibited.

B110213	0x910213	Front turn right lamp open circuit.	Actuator Faults	Wiring harness failure or the load failure.
B110211	0x910211	Front right turn signal lamp short circuit to ground.	Actuator Faults	Wiring harness failure or the load failure.
B110313	0x910313	Rear turn left lamp open circuit.	Actuator Faults	Wiring harness failure or the load failure.
B110311	0x910311	Rear left turn signal lamp short circuit to ground.	Actuator Faults	Wiring harness failure or the load failure.
B110413	0x910413	Rear turn right lamp open circuit.	Actuator Faults	Wiring harness failure or the load failure.
B110411	0x910411	Rear right turn signal lamp short circuit to ground.	Actuator Faults	Wiring harness failure or the load failure.
B110513	0x910513	Low beam open circuit	Actuator Faults	Wiring harness failure or the load failure.
B110511	0x910511	Low beam lamp short circuit to ground.	Actuator Faults	Wiring harness failure or the load failure.
B110613	0x910613	High beam open circuit.	Actuator Faults	Wiring harness failure or the load failure.
B110611	0x910611	High beam short circuit to ground.	Actuator Faults	Wiring harness failure or the load failure.
B110713	0x910713	Parking lamp open circuit.	Actuator Faults	Wiring harness failure or the load failure.
B110711	0x910711	Position lamp short circuit to ground.	Actuator Faults	Wiring harness failure or the load failure.
B110A13	0x910A13	Break lamp open circuit.	Actuator Faults	Wiring harness failure or the load failure.
B110A11	0x910A11	Brake lamp short circuit to ground.	Actuator Faults	Wiring harness failure or the load failure.
B110E11	0x910E11	Handle heat open circuit.	Actuator Faults	Wiring harness failure or the load failure.
B110E13	0x910E13	Handle heating short circuit to ground.	Actuator Faults	Wiring harness failure or the load failure.
U220D00	0xE20D00	L i m p H o m e DTC.	Network Faults	CAN bus circuit is short or open.

© CFMOTO Powersports, Inc. This manual is subject to all applicable copyright laws. Reproduction or duplication in any form, whole or in part, is strictly prohibited.

<b>8.1 Service Tool .....</b>	<b>08-2</b>
<b>8.2 Charging System .....</b>	<b>08-3</b>
8.2.1 Charging Diagram .....	08-3
8.2.2 Magneto Coil Resistance .....	08-3
8.2.3 MAG Non-loaded Performance .....	08-3
8.2.4 Starter Relay .....	08-4
8.2.5 Regulator .....	08-5
<b>8.3 EFI System .....</b>	<b>08-6</b>
8.3.1 EFI Structure .....	08-6
8.3.1.1 Sensors .....	08-6
8.3.1.2 ECU .....	08-6
8.3.1.3 Actuators .....	08-6
8.3.2 EFI System Maintenance Notice .....	08-7
8.3.3 Structure and Performance of EFI Parts .....	08-8
8.3.3.1 ECU .....	08-8
8.3.3.2 Throttle Assembly .....	08-10
8.3.3.3 Air Intake Pressure Sensor .....	08-11
8.3.3.4 Air Intake Temperature Sensor .....	08-12
8.3.3.5 Water Temp. Sensor .....	08-14
8.3.3.6 Oxygen Sensor .....	08-15
8.3.3.7 Trigger .....	08-16
8.3.3.8 Fuel Pump .....	08-18
8.3.3.9 Fuel Injector .....	08-19
8.3.3.10 E-throttle .....	08-20
8.3.3.11 Ignition Coil .....	08-21
8.3.4 UP6.0 Fault Code .....	08-22
<b>8.4 Fault Diagnosis and Treatment .....</b>	<b>08-26</b>
<b>8.5 Trouble Diagnosis by Engine Error .....</b>	<b>08-29</b>

# CFMOTO

---

## 8.1 Service Tool

### CFMOTO DSCAN

**Function :**

Read/clear the EFI system fault code, observe the data flow, update and scrub the ECU program, etc.



### Digital multimeter

**Function:**

Inspect the parameter of EFI system like voltage, current and resistant etc.

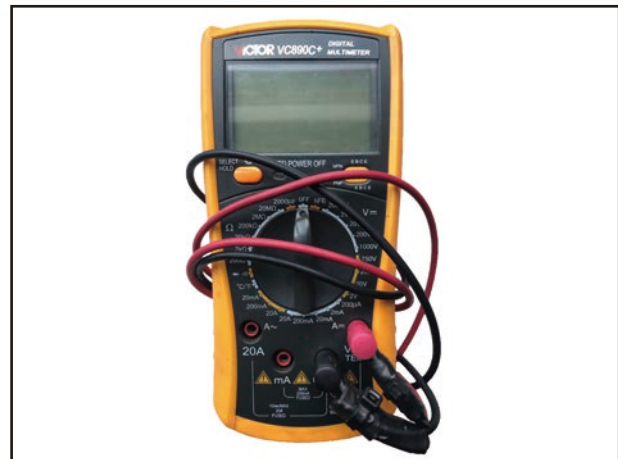

## 8.2 Charging System

### 8.2.1 Charging Diagram

#### 8.2.2 Magneto Coil Resistance

Measure 3-phase magneto stator coil resistance.

If the resistance is out of specification, replace with a new stator.

MAG Coil Resistance:

0.55Ω~1.5Ω (Yellow-Yellow)

Resistance between Stator Coil and Core: ∞Ω (Yellow-Ground)

Check for the insulation between stator coil and core.

Turn multimeter to 1×10Ω

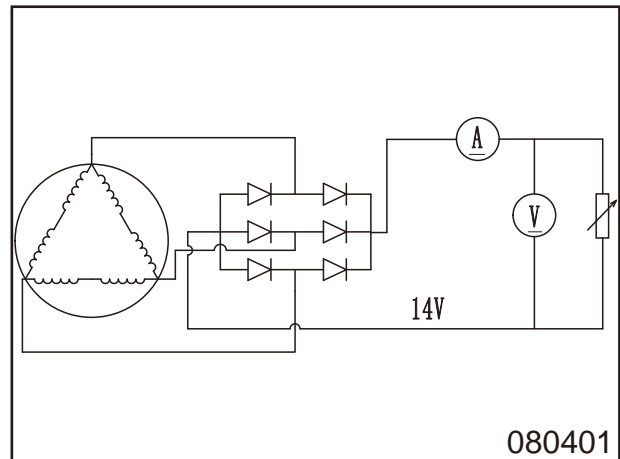

#### 8.2.3 MAG Non-loaded Performance

Start the engine and allow it run at 5000r/min. Use multimeter to measure the voltage between 3 output lines.

If the reading is below specification, replace with a new magneto.

Turn Multimeter to **V(AC)**.

Voltage between Output Lines When MAG Non-loaded:

>50V(AC) at 5000r/min

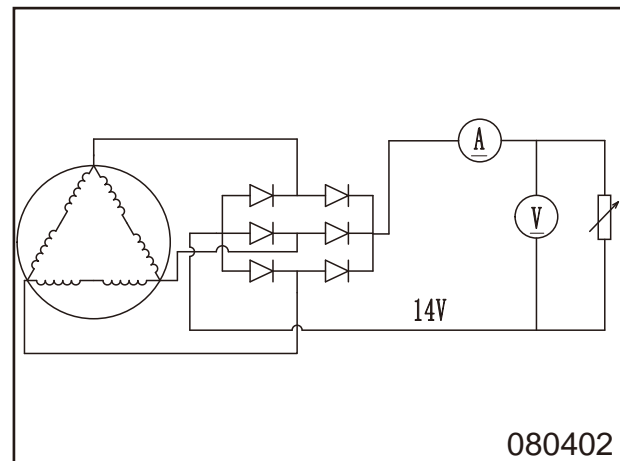

## 8.2.4 Starter Relay

Put DC12V between positive and negative terminal. Use multimeter to check connection between 2 contacts.

If multimeter clicks, there is connection.

If DC12V is removed, no connection between contacts.

If both above 2 items are proved, it indicates the replay is good. Turn multimeter to DIODE.

**⚠ CAUTION: The voltage loaded between terminals can not exceed 2 minutes. Otherwise, starter relay may overheat or burn.**

Use multimeter to measure the start relay coil resistance.

If the resistance is out of standard, replace with a new one.

Turn multimeter to  $1 \times 10 \Omega$

**Start auxiliary relay resistance:  $3 \Omega \sim 5 \Omega$**

## Auxiliary Relay

Put 12V between auxiliary starter relay positive and negative terminal. Use multimeter to check the continuity between A and B.

Turn multimeter to DIODE.

If multimeter clicks, it indicates there is connection between A and B.

If 12V is removed, no connection remains between contacts.

If both above 2 items are proved, it indicates the replay is good.

Turn multimeter to  $1 \times 100 \Omega$  to measure the relay resistance.

**Auxiliary starter relay resistance:  $90 \Omega \sim 100 \Omega$**

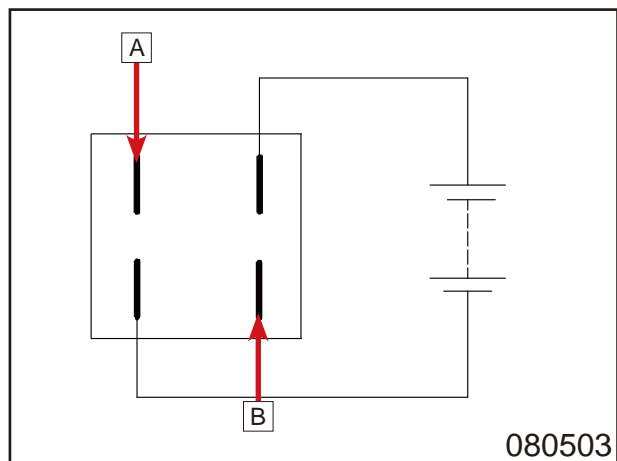
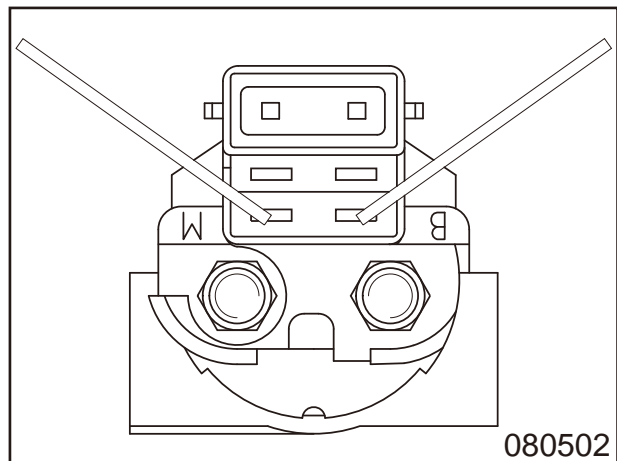
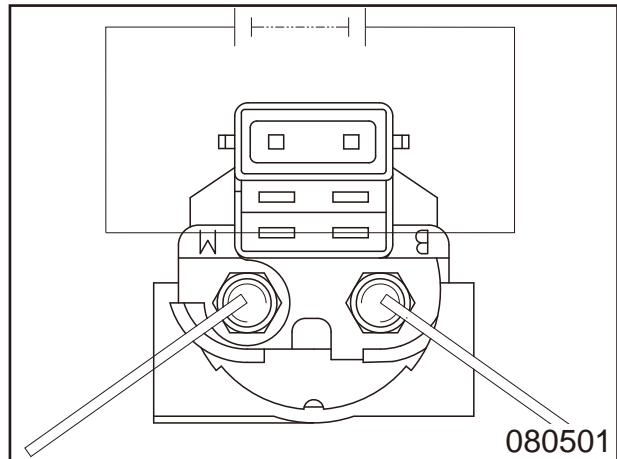

## 8.2.5 Regulator

© CFMOTO Powersports, Inc. This manual is subject to all applicable copyright laws. Reproduction or duplication in any form, whole or in part, is strictly prohibited.

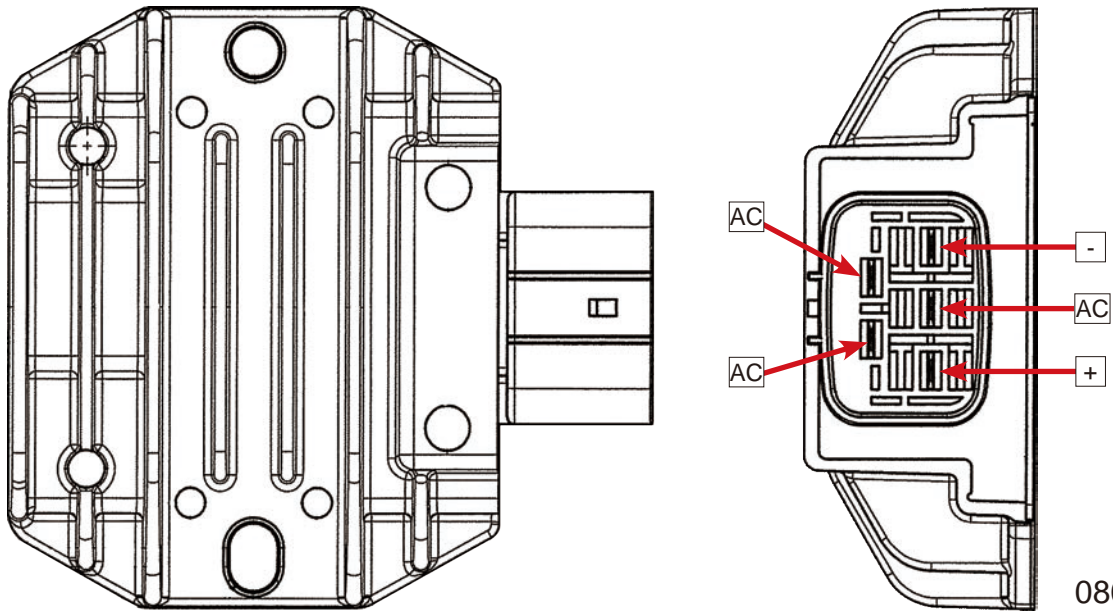

080601

Connecting diagram

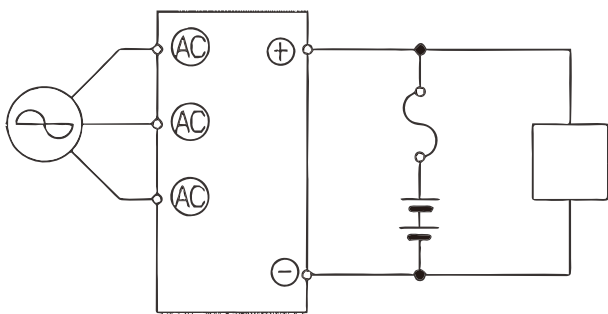

080602

Wire diagram

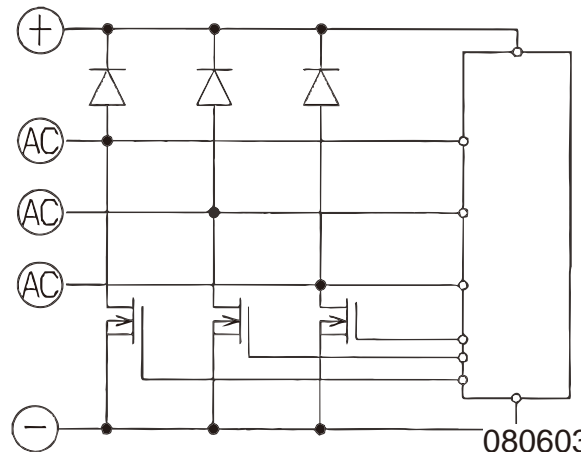

080603

## 8.3 EFI System

### 8.3.1 EFI Structure

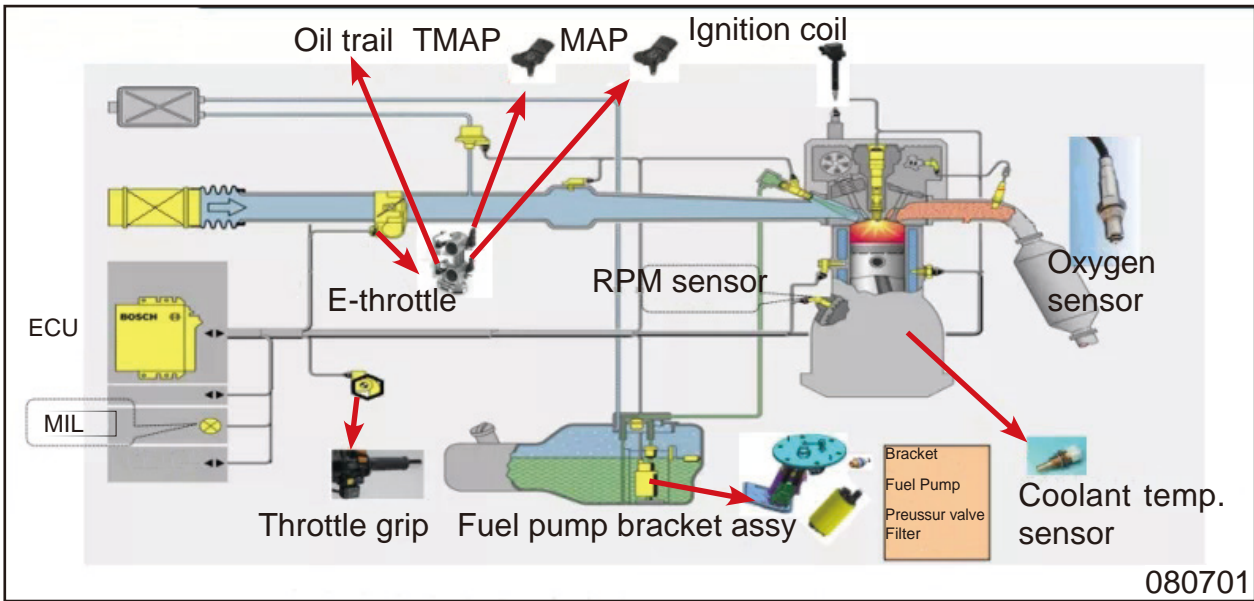

#### 8.3.1.1 Sensors

A sensor is a device that measures a physical quantity and converts it into a signal which can be read by an observer or by an instrument. Sensors in EFI system include:

**Air pressure sensor** (Air density and pressure information)

**Air temp. sensor** (Air density information)

**TPS** (Load, load range, speed information)

**Trigger** (crankshaft information)

**Water temp. sensor** (engine temp.)

**Speedometer sensor** (Output shaft RPM information)

**Oxygen sensor** (Air factor=  $\lambda > 1$  or  $< 1$ )

**Roll-over gear sensor** (Output vehicle gradient information)

#### 8.3.1.2 ECU

Electronic Control Unit, the brain of EFI system, which determines the amount of fuel injection, ignition timing and other parameters a engine needs to keep running by calculating and analyzing values provided by sensors.

#### 8.3.1.3 Actuators

Actuators execute the EFI instruction. Main actuators include:

**Fuel Pump** (Provide high-pressure fuel)

**Fuel Injector** (Inject the fuel to make it spray better)

**Ignition Coil** (Provide high ignition energy to spark plug)

**Idle Air Control Valve** (Provide idle inlet air)

### 8.3.2 EFI System Maintenance Notice

- Always use genuine CFMOTO parts for maintenance. Otherwise it can not assure a normal performance to EFI system.

- During the maintenance procedure, never try to break down the EFI components.

- In the course of maintenance, EFI parts must be handled carefully.

- Ignition switch must be shut off before connecting or disconnecting connectors. Otherwise, it may cause the EFI parts damage.

- When removing fuel pump from fuel tank, do not energize the fuel pump. Otherwise, a spark can cause a fire.

- Fuel pump is not allowed to operate in a dry environment or under water. Otherwise, its life would be shortened. Besides, reverse connections between positive and negative terminal of fuel pump is not permitted.

- The fuel pressure in EFI fuel supply system is very high (about 330kPa), accordingly, all fuel lines are high pressure resisting. Even if the engine is not running, the fuel pressure is high. Therefore, do not disassemble the fuel line unless it's necessary.

When the fuel line needs to be repaired, release the fuel pressure as follow shows:

**Remove fuel pump relay, start the engine and allow it to idle until the engine stalls automatically.**

Fuel line removal and fuel filter replacement should be practiced by a professional person in a well-ventilated place.

- If possible, don't do the spark test. If spark test is done unavoidably, try to complete the test as soon as possible. Besides, don't open the throttle, otherwise, a large quantity of unburnt fuel would enter muffler, causing the catalytic converter damage.

- Idle speed is controlled by ECU, so it's unadjustable. The throttle limiter screw has been adjusted by manufacturer before sale. Therefore, it's not recommended to adjust it by the user.

- Don't reverse the battery cable connections. This may damage electrical components.

- Never remove the battery cables When the engine is running.

- Always remove cables and electrical control units which are connected with battery terminals.

- Never test the component input and output electric signal by piercing the cable plastic jacket.

- Respect the environment and dispose of the waste left during maintenance.

## 8.3.3 Structure and Performance of EFI Parts

### 8.3.3.1 ECU

Electronic control unit , is the brain of EFI system. It analyzes and cope with the information provided by sensors, and send the conclusion in the form of instruction to actuator, then make the engine run in the optimal condition.

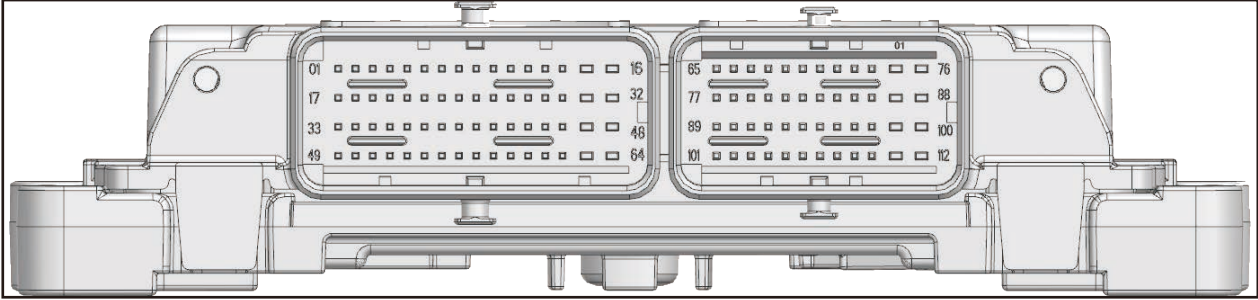

#### ECU pin function:

No.	Pin function	No.	Pin function	No.	Pin function
1	CAN high	39		77	TPS 1
2		40		78	TPS 2
3		41	Fuel pump relay	79	Gearshift shaft sensor signal
4		42	Headlight relay	80	Sensor 1 to ground
5	Main relay	43	Oxygen sensor 2 to ground	81	
6		44	Clutch switch	82	
7	Pedal 1 to ground	45	Override pedal sensor 1	83	Sensor to ground 6
8		46		84	Sensor to ground
9	Cruise control	47	AGND	85	Intake manifold sensor to ground
10		48	Oxygen sensor heated 2	86	TPS to ground
11		49		87	Throttle actuator B
12	Air intake pressure sensor	50		88	
13	Rain mode switch	51		89	
14		52		90	
15	Interruptible battery	53		91	Air intake pressure sensor 1
16	Interruptible battery	54		92	
17	CAN Low	55		93	
18	K-line	56	Fan control 1	94	Canister control valve
19	5V battery	57		95	
20	Uninterrupted battery	58	Starter control relay	96	Engine RPM sensor A
21	Oxygen sensor 2	59	Pedal 2 to ground	97	Engine RPM sensor B
22		60		98	5V power
23	Brake switch	61		99	Ignition coil 2
24		62		100	Ignition coil 1
25	Brake light switch	63	ECU to ground 2	101	Engine coolant temp. sensor
26		64	ECU to ground 1	102	Air intake temp. sensor 1
27		65		103	Gearshift sensor signal
28		66		104	Oxygen sensor 1
29	Side stand switch	67		105	
30	Override pedal sensor 2	68	Fuel injector 1	106	
31		69		107	Throttle 5V power
32		70		108	5V power
33		71	AIS solenoid valve	109	Intake manifold sensor 5V power

## 08 Electrical System

34		72	Fuel injector 2	110	
35	Ignition switch	73	Oxygen sensor heated 1	111	ECU to ground 4
36	Pedal 2 5V power	74		112	ECU to ground 3
37	Pedal 1 5V power	75	Throttle actuator A		
38		76			

### ECU (Europe+) pin function:

No.	Pin function	No.	Pin function	No.	Pin function
1	CAN H	39		77	TPS 1
2		40		78	TPS 2
3		41	Fuel pump relay	79	Shift trend sensor
4		42	Headlight relay	80	Front oxygen sensor 1 GND
5	Main relay	43	Oxygen sensor	81	
6		44	Clutch switch	82	
7	Pedal 1 GND	45	Accelerator pedal sensor 1	83	Oxygen sensor GND
8		46	Air intake pressure signal 2	84	Oxygen sensor GND
9	Cruise control input	47	AGND	85	Intake manifold sensor GND
10	Speed input	48	Rear oxygen heating cylinder 1	86	TPS GND
11		49		87	Throttle actuator B
12	Rear oxygen signal cylinder 2	50		88	
13	Driving mode switch	51		89	Knock B
14		52		90	Knock A
15	Non-continuous power 1	53		91	Air intake pressure sensor
16	Non-continuous power 2	54		92	
17	CAN L	55		93	
18		56	Fan control 1 (low speed)	94	Canister control valve
19	5V power	57		95	NULL
20	Continuous power	58	Starter motor control relay	96	Engine RPM sensor A
21	Rear oxygen signal cylinder 1	59	Pedal 2 GND	97	Engine RPM sensor B
22		60		98	Gearshift lever trend sensor power 5V
23	Brake switch	61		99	Ignition coil 2
24	Gear signal	62	Roll-over sensor	100	Ignition coil 1
25	Brake light switch	63	ECU GND 2	101	Engine temp. sensor
26		64	ECU GND 1	102	Air intake temp. sensor
27		65	Front oxygen heating cylinder 2	103	Front oxygen signal cylinder 2
28		66		104	Front oxygen signal cylinder 1
29	Side stand switch	67		105	
30	Accelerator pedal sensor 2	68	Fuel injector 1(cylinder 1)	106	
31	Fan control 1(high speed)	69	Rear oxygen heating cylinder 2	107	TPS 5V power
32		70		108	
33		71	SAS magnetic valve	109	TPS 5V power
34		72	Fuel injector 2(cylinder 2)	110	
35	Ignition switch	73	Front oxygen heating cylinder 1	111	ECU GND 4
36	Pedal 2 5V power	74		112	ECU GND 3
37	Pedal 1 5V power	75	Throttle actuator A		
38		76			

Item		Value			Unit
		Min.	Standard	Max.	
Battery voltage	Normal	9	14±0.1	16	V
	Limit function	6.0~9.0		16.0~18.0	V
Limit and time of battery over voltage	26.0V	Keep part of function, can diagnose the trouble		5	min
Working temperature		-40		70	°C
Storage temperature		-40		70	°C

### 8.3.3.2 Throttle Assembly

Connect with air filter and the engine, control the on-off angle of throttle by throttle cable. Send out the angle signal through TPS to ECU.

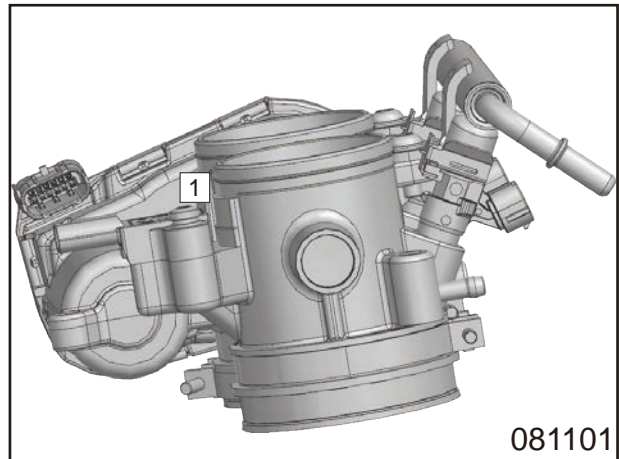

#### Pin Function:

1. Motor +
2. Motor -
3. Sensor to ground
4. Signal 2
5. Sensor power
6. Signal 1

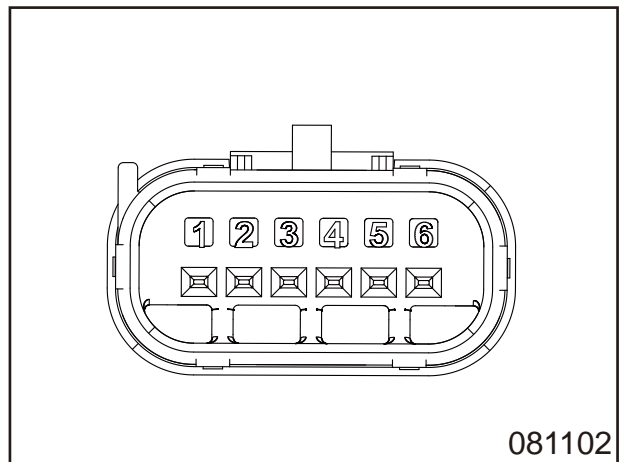

Circuit connecting with ECU.

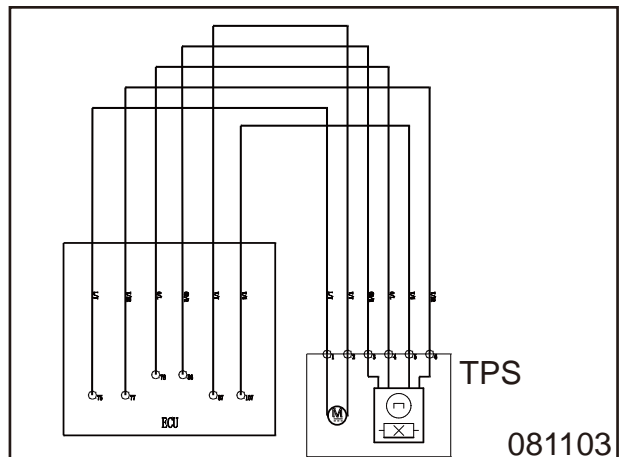

## 8.3.3.3 Air Intake Pressure Sensor

This sensor detects the pressure of air intake pipe, which provides the engine load signal to ECU.

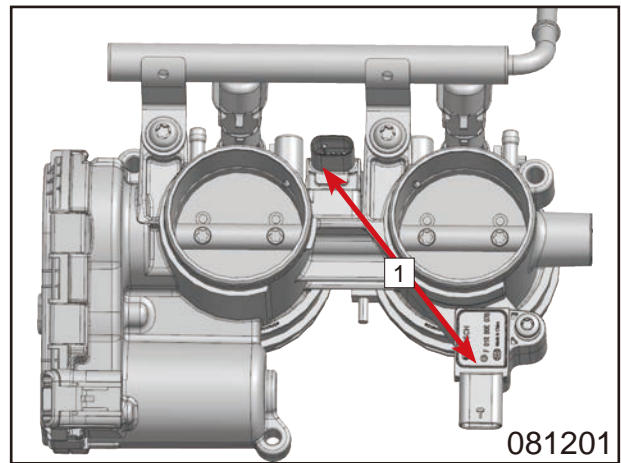

### Pin Function:

- 1. Power
- 2. Ground
- 3. Output voltage

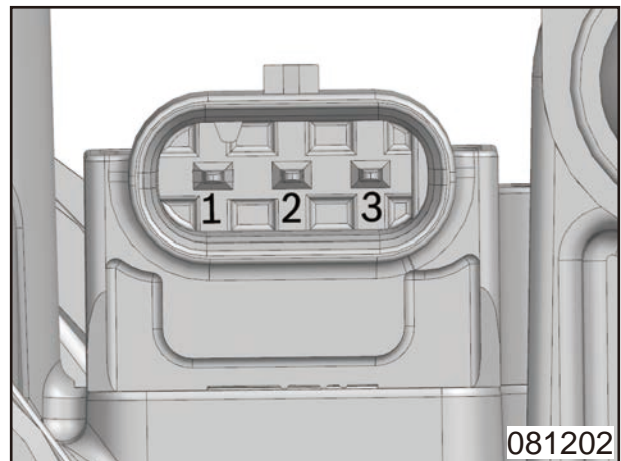

Circuit connecting with ECU.

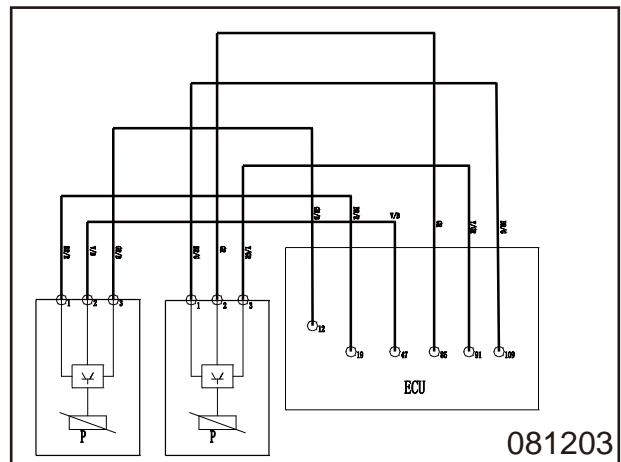

Air intake pressure sensor 1      Air intake pressure sensor 2

## 8.3.3.4 Air Intake Temperature Sensor

This sensor is a NTC thermo resistance. The resistance becomes lower when the air temperature becomes higher, but it is not a liner relationship.

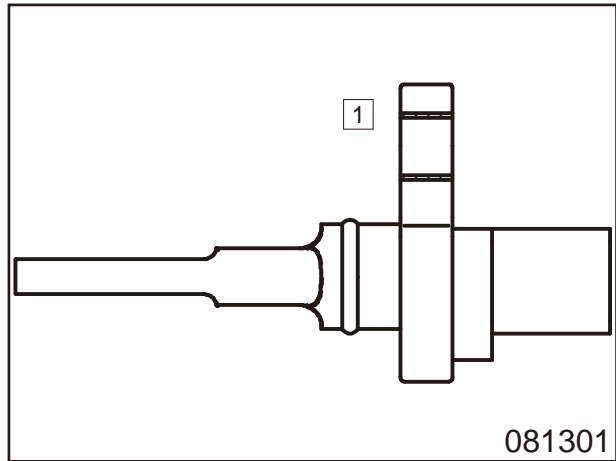

Circuit connecting with ECU.

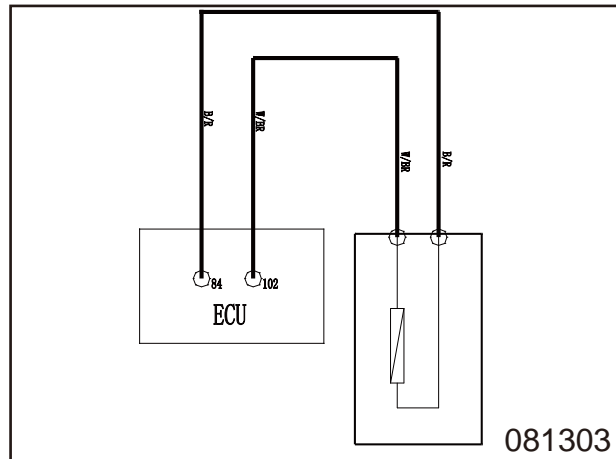

Air intake temperature sensor

The relationship between output voltage and pressure.

Pressure range: 10~115kPa

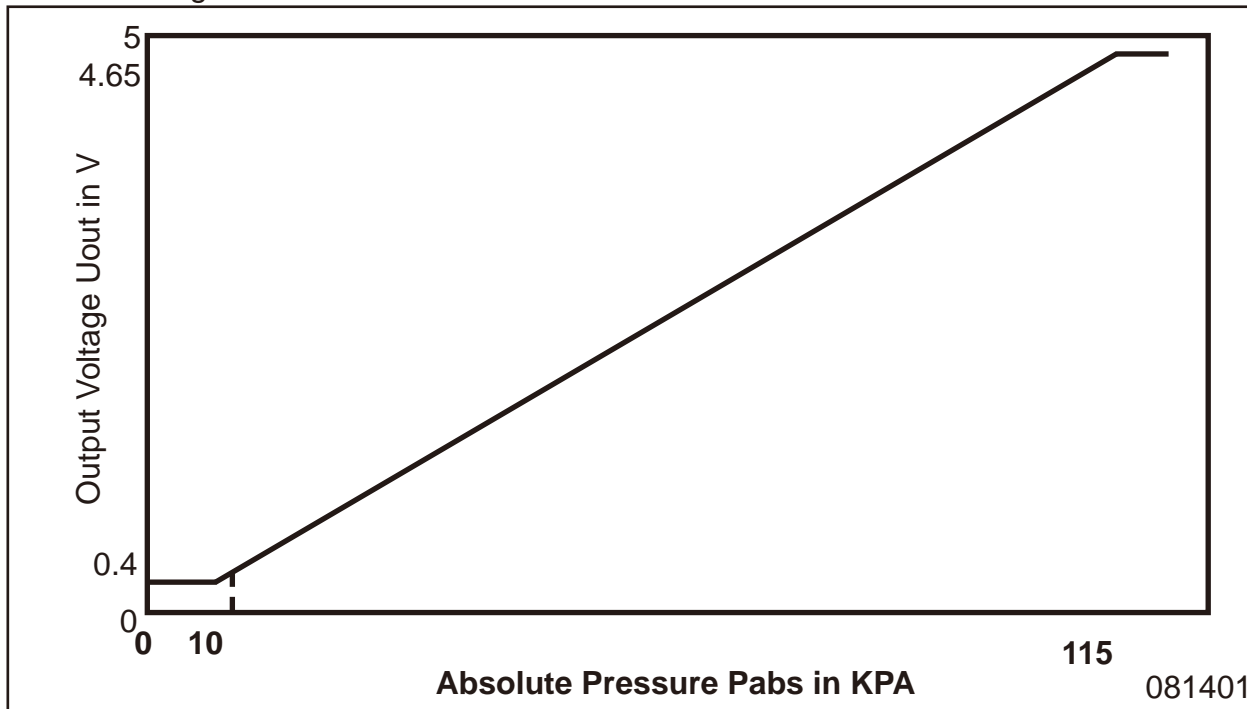

081401

The relationship between sensor temperature and resistance.

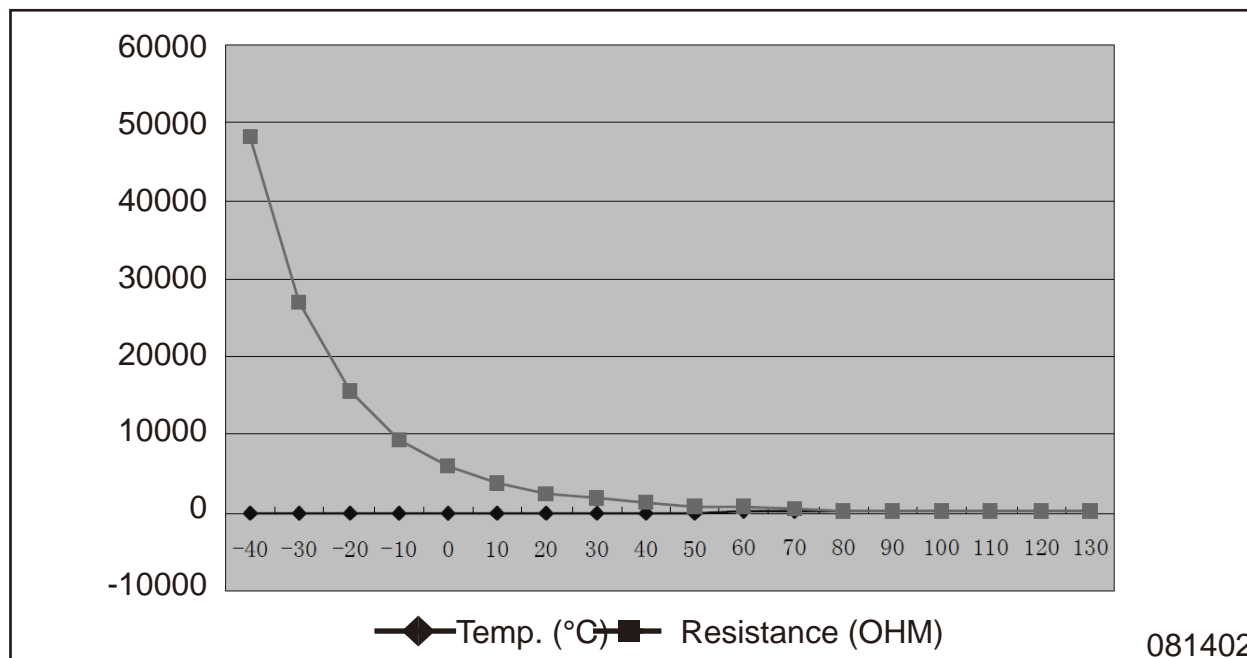

081402

© CFMOTO Powersports, Inc. This manual is subject to all applicable copyright laws. Reproduction or duplication in any form, whole or in part, is strictly prohibited.

## 8.3.3.5 Water Temp. Sensor

This sensor is a NTC thermo resistance. The resistance becomes lower when the air temperature becomes higher.

One group of parameters is sent to ECU to monitor engine temperature condition, One group is sent to dashboard to monitor coolant temperature condition.

A and C are one group which provides water temperature signal to the ECU.

Through ECU, B sends the water temperature signal to dashboard.

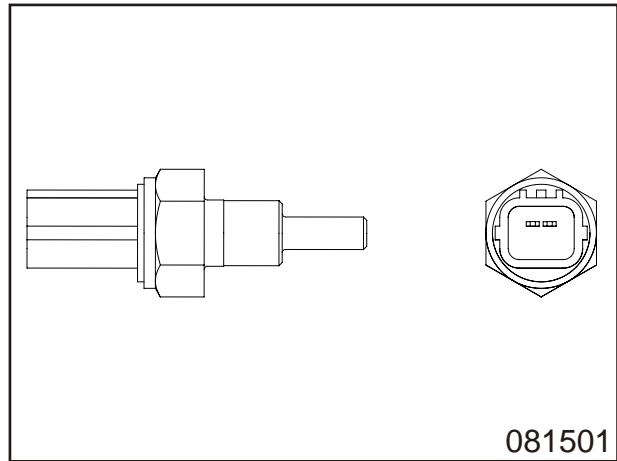

Circuit connecting with ECU.

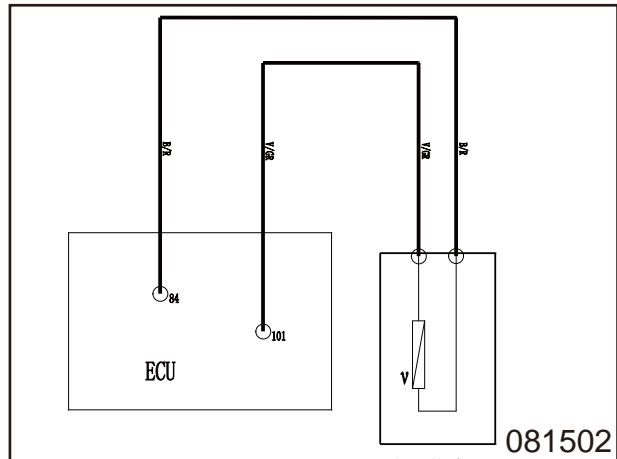

Water temp. sensor

The right table shows the relationship between temperature and resistance. This signal is sent to ECU.

Temp. °C	Resistance between B and housing (KΩ)
-20±0.1	13.71~16.94
25±0.1	1.825~2.155
80±0.1	0.303~0.326
110±0.1	0.1383~0.1451

## 8.3.3.6 Oxygen Sensor

This sensor is used in closed-loop feedback controlled fuel injection to improve the air-to-fuel ratio accuracy and control the emission. It's located in the exhaust stream to measure the amount of oxygen in exhaust and send the signal to ECU, which can revise the fuel injector output, so as to reduce the amounts of unburnt fuel and make catalytic converter convert HC, CO and NO<sub>x</sub> of Nitrogen efficiently.

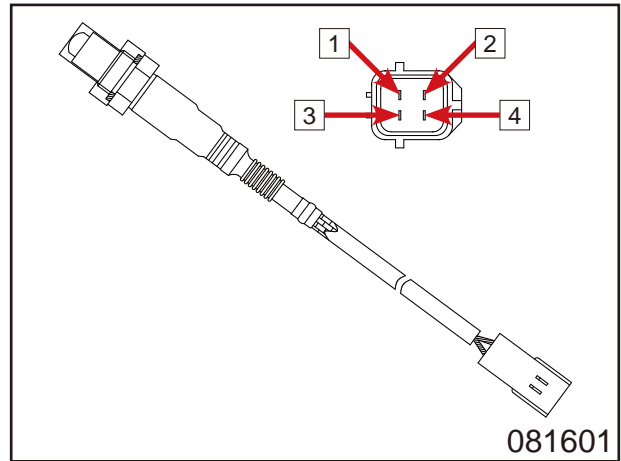

081601

### Pin Function:

1. Output signal +
2. Output signal -
3. Heated ground -
4. Heated power +

Circuit connecting with ECU.

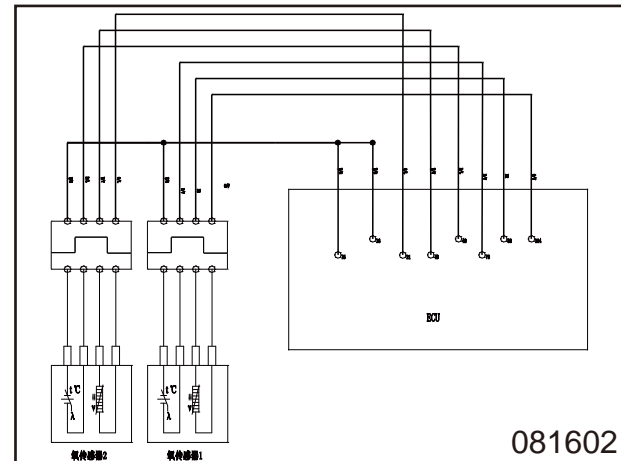

081602

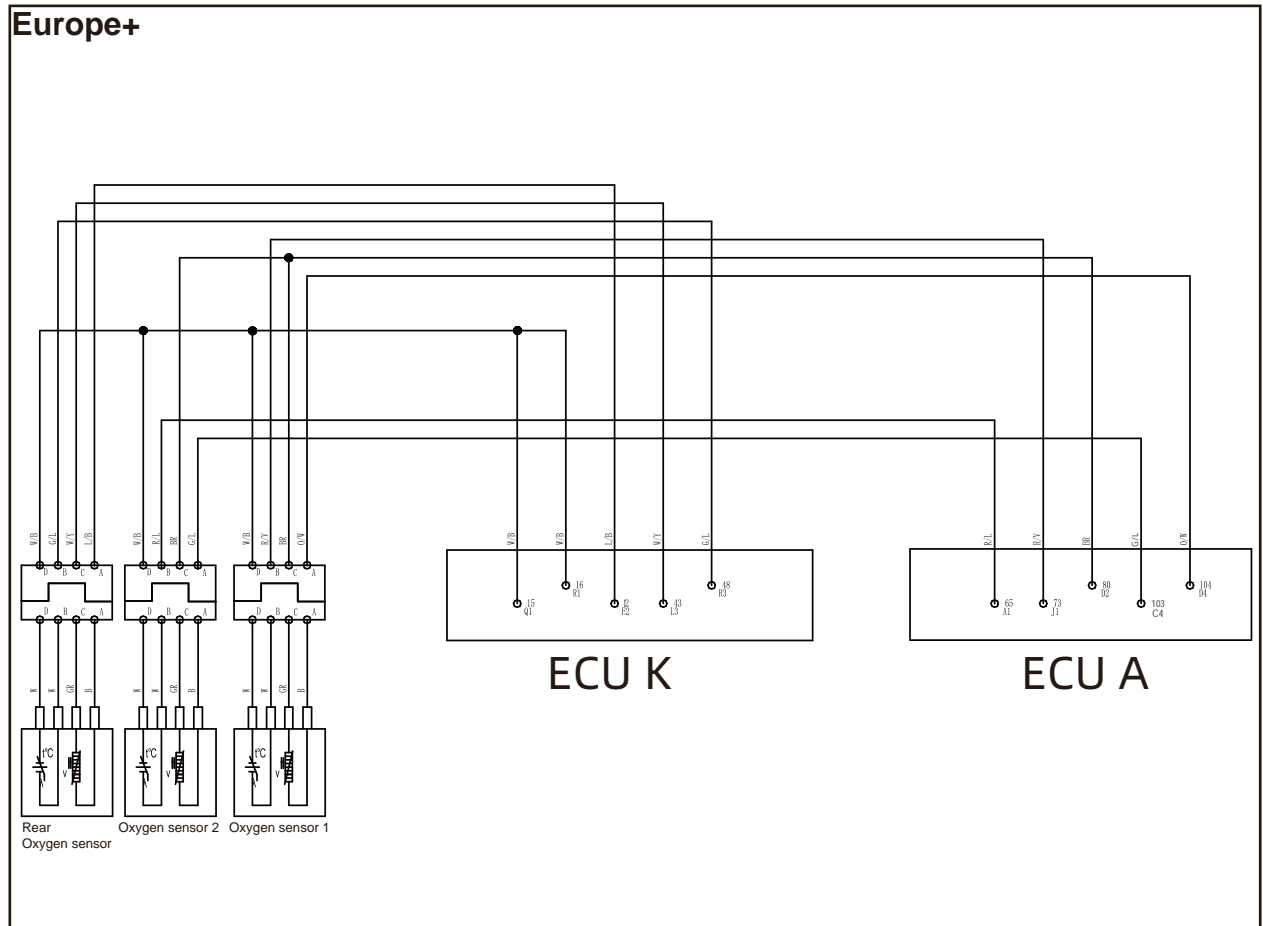

## 8.3.3.7 Trigger

The trigger transfers signal of engine speed to ECU and by which ECU to confirm engine speed ignition angle and injecting phase.

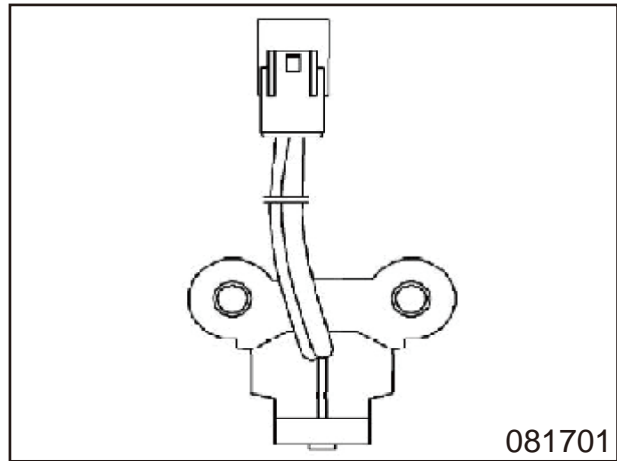

Circuit connecting with ECU.

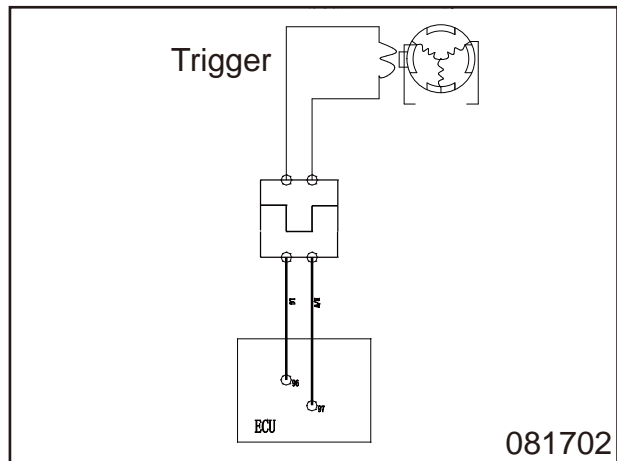

### Magneto Coil Path Inspection

Measure the path between any pin of the three-phase magneto stator coil. If there is no path, replace it with a new one.

Set the multimeter on the buzzer gear. Measure the path between pins.

The chart on the right shows the measurement guideline.

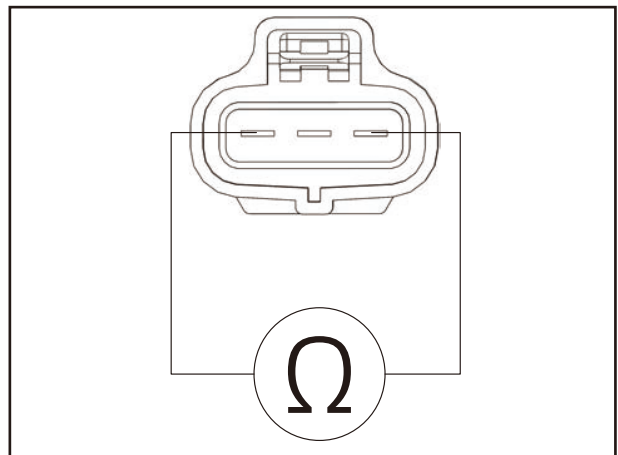
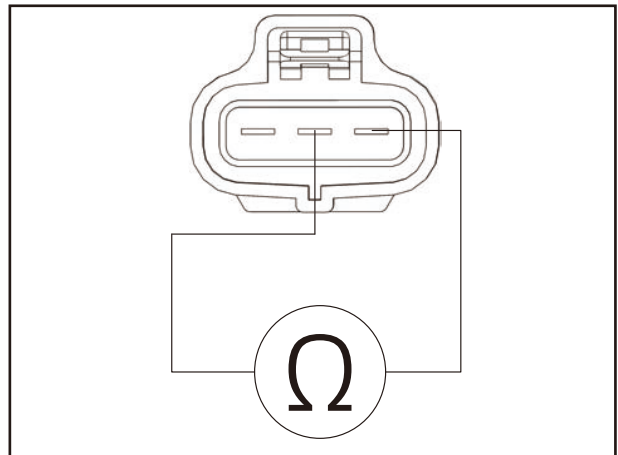
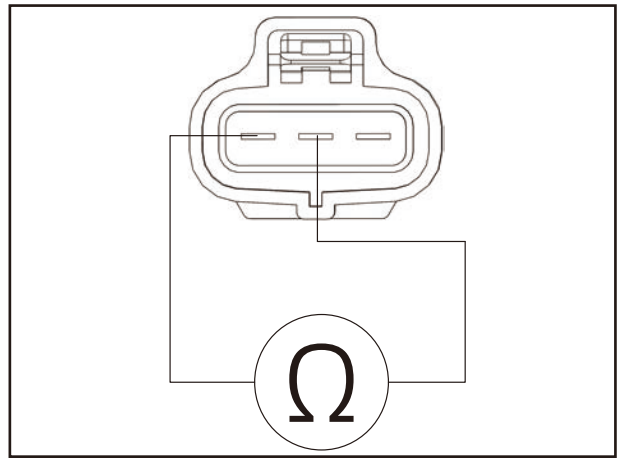

## 8.3.3.8 Fuel Pump

The right picture shows the fuel pump assy, fuel pump relay and ECU wiring diagram.

This fuel pump assy consists of fuel pump, plastic bracket, fuel strainer, fuel filter element and pressure-regulating valve. It delivers fuel from the tank to the engine at a certain oil pressure and flow rate.

### Pin function:

- 1 Ground
- 2 Fuel pump relay output port

### Performance parameter:

Pressure-regulating valve open pressure:  
0.4MPa±0.007MPa

Flow rate: 80L/h

Do not run the fuel pump assy when there is no fuel inside the fuel tank, in case of fuel pump damage.

Handle the fuel pump gently. Do not drop it on hard surfaces.

The battery supplies power to the fuel pump through the relay. Only when starting or running the engine can the circuit be switched on.

### Measure fuel pressure:

Connect oil pressure gauge and fuel pump oil port, lock with clamp to ensure there is no leak from the junction.

Connect the circuit as the picture shows.

Turn on ignition switch and stop switch.

The fuel pump will work for 5 seconds. When stop working, the oil pressure should reach the specified value. Otherwise, replace with a new fuel pump.

After stopping working, the pressure should maintain **0.2MPa for at least 5 minutes**. Otherwise, replace fuel pump assy.

### Fuel hose pressure release method:

The fuel supply pressure in EFI system is high, all fuel hoses are high-pressure resistance. Even the engine does not work, the pressure in fuel passage is still high. So when in the maintenance process, be careful not to remove the fuel hose causally. When servicing EFI system, release the pressure before removing the fuel hose. Remove the fuel pump relay. Start the engine and make it idle until the engine stops automatically.

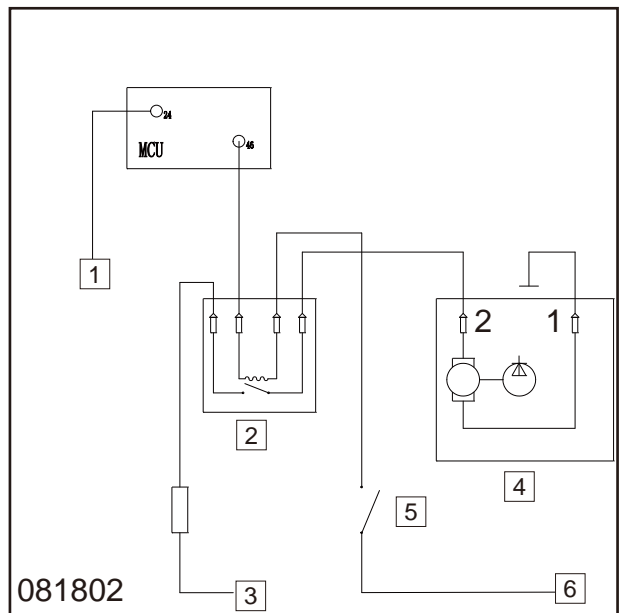
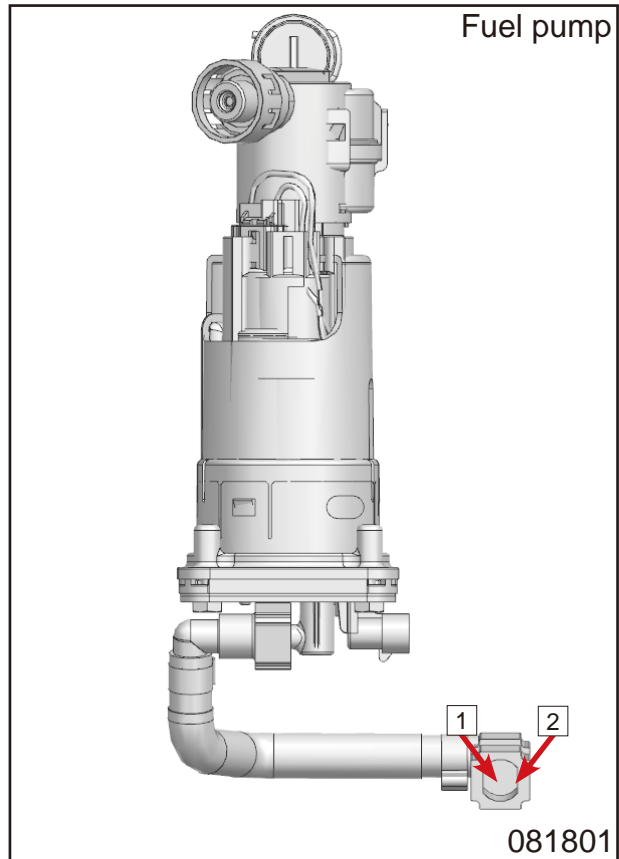

1	ECU pin 41	3	Battery +	5	Stop switch
2	Fuel pump relay	4	Fuel pump assy	6	Ignition switch

## 8.3.3.9 Fuel Injector

One end of fuel injector mounts into fuel injector seat, and the other end attaches to the injector cap, which connects with a fuel line. Fuel injector is controlled by ECU to inject fuel at stated time into the engine. This injector nozzle is a 4-hole style. Don't turn injector after the joint between injector and injector cap is installed.

### Pin function:

- 1: + connects fuel pump relay output
- 2: - connects ECU

Fuel injector resistance:  $12\Omega \pm 0.6\Omega$  ( 20°C )

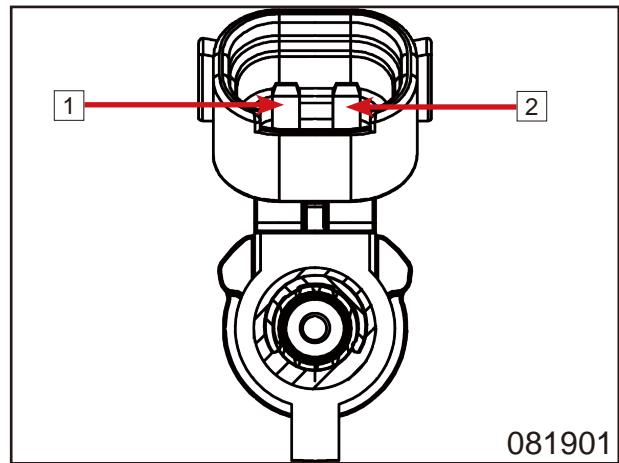

1	Fuel pump relay	2	ECU
---	-----------------	---	-----

Circuit connecting with ECU.

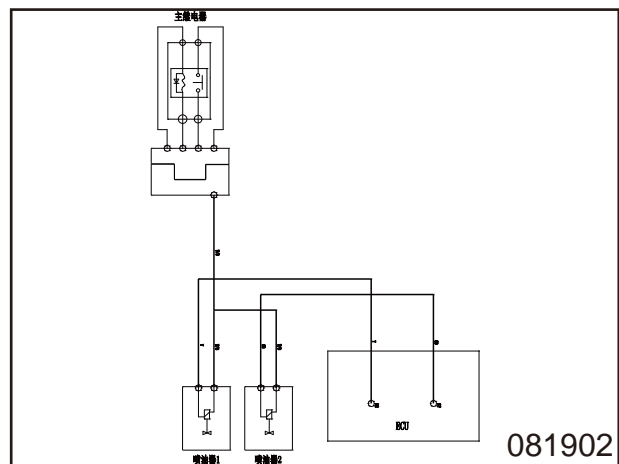

### Fuel Injector Installation

Install fuel injector manually. Never knock fuel injector with a hammer.

When removing and installing fuel injector, the O-rings on both ends must be replaced.

Perform pressure relief before fuel injector removal if necessary.

Test the fuel injector sealing after installation to ensure no leaks.

## 8.3.3.10 E-throttle

The vehicle adopts e-throttle assy. When the driver turns the throttle grip, ECU combines the throttle angle, engine RPM, gear, engine temperature, vehicle mode and other information to provide the best fuel supply.

The e-throttle assy can provide the driver with more accurate fuel supply and more ideal throttle response.

### Pin function:

1. Power 1
2. Signal 1
3. Ground 1
4. Signal 2
5. Ground 2
6. Power 2

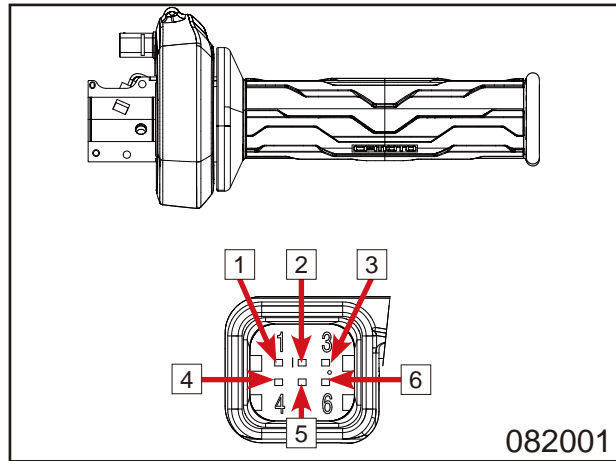

Circuit connecting with ECU.

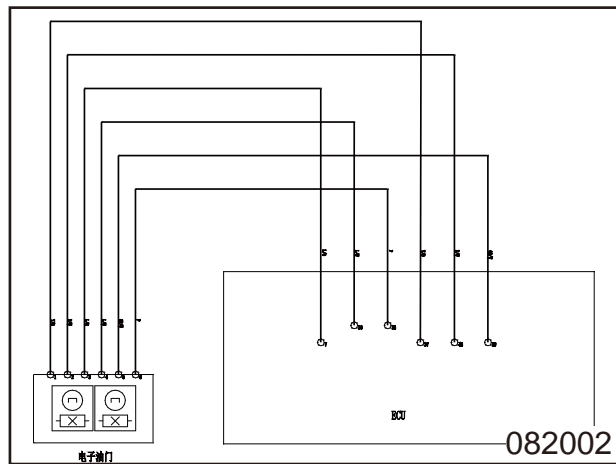

## 8.3.3.11 Ignition Coil

Ignition coil transforms the low voltage of primary coil to high voltage of secondary coil needed to spark the spark plug and ignite the mixture of air and fuel in cylinder.

### Pin function:

1. Signal
2. Ground
3. Power

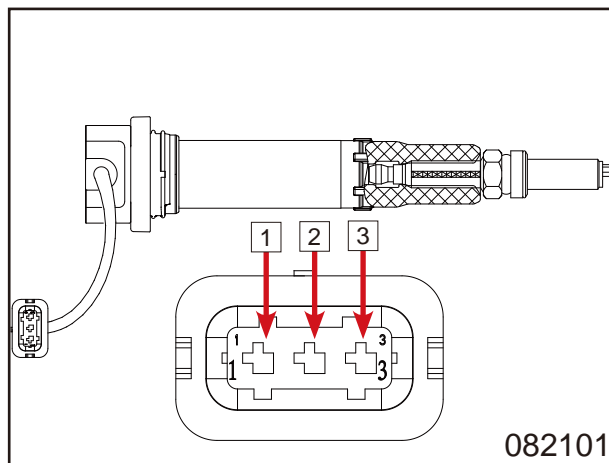

082101

Circuit connecting with ECU.

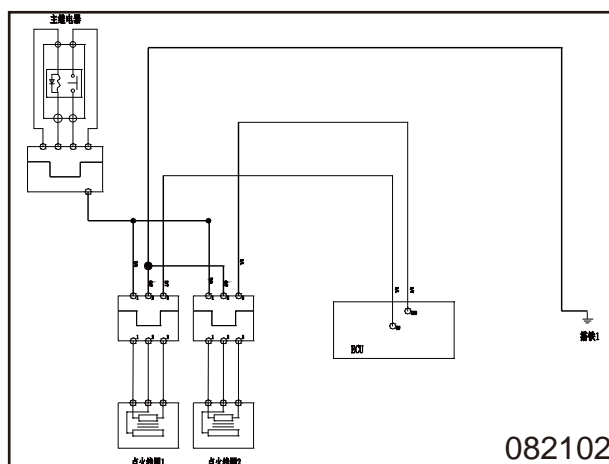

082102

### Secondary Ignition Voltage Test:

Connect the engine according to EFI wiring diagram.

Connect the peak voltage tester according to the right diagram.

Start the engine.

Secondary ignition voltage should be more than **15 kV**.

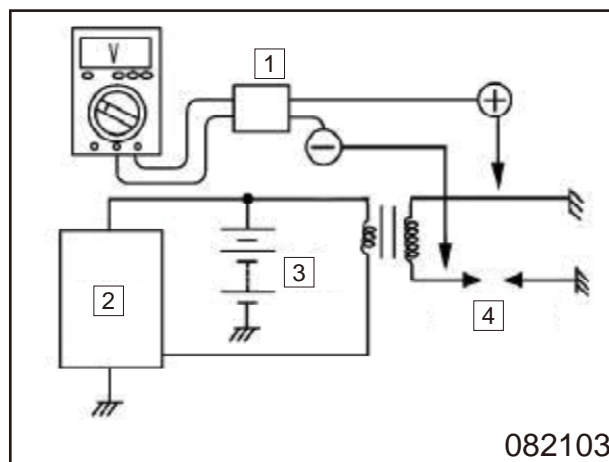

082103

1	Peak voltage gauge	3	Battery
2	ECU	4	Spark plug

### Ignition coil parameter chart table:

Item	Value				
	Min	Standard	Max	Unit	
Stated Voltage		14		V	
Operating Voltage	6		16.5	V	
Resistance (20°C~25°C)	Primary	0.8	1.1	1.4	Ω
	Secondary	12.5	13.0	13.5	kΩ
Primary Current		7		A	

## 8.3.4 UP6.0 Fault Code

No.	Code	Instruction
1	P0322 00	Crankshaft signal loss
2	P0108 17	Manifold Absolute Pressure/Barometric Pressure Circuit High
3	P0107 16	Manifold Absolute Pressure/Barometric Pressure Circuit Low
4	P0106 29	Manifold Absolute Pressure/Barometric Pressure Circuit Range/Performance
5	P0105 23	Manifold Absolute Pressure/Barometric Pressure Circuit
6	P2A0D 17	Manifold Absolute Pressure Sensor "B" Circuit High
7	P2A0C 16	Manifold Absolute Pressure Sensor "B" Circuit Low
8	P2A0B 29	Manifold Absolute Pressure Sensor "B" Circuit Range/Performance
9	P2A0A 23	Manifold Absolute Pressure Sensor "B" Circuit
10	P0113 17	Intake Air Temperature Sensor 1 Circuit High
11	P0112 16	Intake Air Temperature Sensor 1 Circuit Low
12	P0111 29	Intake Air Temperature Sensor 1 Circuit Range/Performance
13	P0118 17	Engine Coolant Temperature Sensor 1 Circuit High
14	P0117 16	Engine Coolant Temperature Sensor 1 Circuit Low
15	P0116 29	Engine Coolant Temperature Sensor 1 Circuit Range/Performance
16	P0688 16	ECM/PCM Power Relay Sense Circuit/Open
17	P0688 29	ECM/PCM Power Relay Sense Circuit/Open
18	P0650 12	MIL Control Circuit High
19	P0650 11	MIL Control Circuit Low
20	P0650 13	MIL Control Circuit Open
21	P0692 12	Fan 1 Control Circuit High
22	P0691 11	Fan 1 Control Circuit Low
23	P0480 13	Fan 1 Control Circuit
24	P0629 12	Fuel Pump "A" Control Circuit High
25	P0628 11	Fuel Pump "A" Control Circuit Low
26	P0627 13	Fuel Pump "A" Control Circuit /Open
27	P0459 12	Evaporative Emission System Purge Control Valve Circuit High
28	P0458 11	Evaporative Emission System Purge Control Valve Circuit Low
29	P0444 13	Evaporative Emission System Purge Control Valve Circuit Open
30	P0497 00	Evaporative Emission System Incorrect Purge Flow
31	P0917 17	Gear Shift Position Circuit High
32	P0916 16	Gear Shift Position Circuit Low
33	P0915 29	Gear Shift Position Circuit Range/Performance
34	P1001 00	Shaft Gears Position Sensor Self-learning Not plausible (Gangi=0)
35	P082C 00	Shaft Gears Position Sensor Circuit High
36	P082B 00	Shaft Gears Position Sensor Circuit Low
37	P1002 00	Shaft Gears Position Sensor Self-learning Not plausible (Gangi~=0)
38	P0412 12	Secondary Air Injection System Switching Valve "A" Circuit
39	P0414 11	Secondary Air Injection System Switching Valve "A" Circuit Shorted

## 08 Electrical System

40	P0413 13	Secondary Air Injection System Switching Valve "A" Circuit Open
41	P0411 29	Secondary Air Injection System Incorrect Flow Detected
42	P0568 1C	Cruise Control Multi-Function Input "A" Circuit Range/Performance
43	P0568 24	Cruise Control Multi-Function Input "A" Circuit Stuck
44	P0568 13	Cruise Control Multi-Function Input "A" Circuit
45	P0262 12	Cylinder 1 Injector Circuit High
46	P0261 11	Cylinder 1 Injector Circuit Low
47	P0201 13	Injector Circuit/Open – Cylinder 1
48	P0265 12	Cylinder 2 Injector Circuit High
49	P0264 11	Cylinder 2 Injector Circuit Low
50	P0202 13	Injector Circuit/Open – Cylinder 2
51	P0268 12	Cylinder 3 Injector Circuit High
52	P0267 11	Cylinder 3 Injector Circuit Low
53	P0203 13	Injector Circuit/Open – Cylinder 3
54	P0271 12	Cylinder 4 Injector Circuit High
55	P0270 11	Cylinder 4 Injector Circuit Low
56	P0204 13	Injector Circuit/Open – Cylinder 4
57	P0563 17	System Voltage High
58	P0562 16	System Voltage Low
59	P0560 1C	System Voltage Not plausible
60	P0501 29	Vehicle Speed Sensor "A" Range/Performance
61	P0507 00	Idle Air Control System RPM Higher Than Expected
62	P0506 00	Idle Air Control System RPM Lower Than Expected
63	P1098 00	DUMP control Circuit low
64	P1099 00	DUMP control Circuit high
65	P0641 00	Sensor Reference Voltage "A" Circuit/Open
66	P0651 00	Sensor Reference Voltage "B" Circuit/Open
67	P0571 29	Brake Switch "A" Circuit
68	P0571 1C	Brake Switch "A" Circuit
69	P2138 00	Throttle/Pedal Position Sensor/Switch "D"/"E" Voltage Correlation
70	P0326 17	Max error of DFP_KS1: internal failure path number: knock sensor 1
71	P0325 17	Min error of DFP_KS1: internal failure path number: knock sensor 1
72	P0328 00	Knocksensor fault: short circuit sensor 1, line A, Max
73	P0327 00	Knocksensor fault: short circuit sensor 1, line A, Min
74	P0328 15	Knocksensor fault: short circuit sensor 1, line B, Max
75	P0327 14	Knocksensor fault: short circuit sensor 1, line B, Min
76	P1386 00	Diagnostic Fault Check knock control signal evaluation
77	P0300 00	Misfire detected
78	P0301 00	Misfire detected on cylinder 1
79	P0303 00	Misfire detected on cylinder 3
80	P0304 00	Misfire detected on cylinder 4
81	P0302 00	Misfire detected on cylinder 2
82	P130A 00	Cylinder selective fuel cutoff active due to catalyst damaging misfire

# CFMOTO

83	P0300 22	Random/Multiple Cylinder Misfire Detected
84	P0300 21	Random/Multiple Cylinder Misfire Detected
85	P0300 29	Random/Multiple Cylinder Misfire Detected
86	P2301 00	Ignition Coil "A" Primary Control Circuit High
87	P2307 00	Ignition Coil "C" Primary Control Circuit High
88	P2310 00	Ignition Coil "D" Primary Control Circuit High
89	P2304 00	Ignition Coil "B" Primary Control Circuit High
90	P2300 00	Ignition Coil "A" Primary Control Circuit Low
91	P2306 00	Ignition Coil "C" Primary Control Circuit Low
92	P2309 00	Ignition Coil "D" Primary Control Circuit Low
93	P2303 00	Ignition Coil "B" Primary Control Circuit Low
94	P0123 17	Throttle/Pedal Position Sensor/Switch "A" Circuit High
95	P0122 16	Throttle/Pedal Position Sensor/Switch "A" Circuit Low
96	P0121 29	Throttle/Pedal Position Sensor/Switch "A" Circuit Range/ Performance
97	P0223 17	Throttle/Pedal Position Sensor/Switch "B" Circuit High
98	P0222 16	Throttle/Pedal Position Sensor/Switch "B" Circuit Low
99	P0221 29	Throttle/Pedal Position Sensor/Switch "B" Circuit Range/ Performance
100	P2106 12	Throttle Actuator Control System Forced Limited Power
101	P2106 19	Throttle Actuator Control System Forced Limited Power
102	P2106 92	Throttle Actuator Control System Forced Limited Power
103	P2106 13	Throttle Actuator Control System Forced Limited Power
104	P1568 00	Idle Speed Contr.Throttle Pos. mechanical Malfunction
105	P1545 00	Throttle Pos.Contr. Malfunction
106	P1559 00	Idle Speed Contr.Throttle Pos. Adaptation Malfunction
107	P1545 22	Throttle Pos.Contr. Malfunction
108	P1545 21	Throttle Pos.Contr. Malfunction
109	P1579 00	Idle Speed Contr.Throttle Pos. adaptation not started
110	P1564 00	Idle Speed Contr.Throttle Pos. Low Voltage During Adaptation
111	P1565 00	Idle Speed Control Throttle Position lower limit not attained
112	P1559 29	Idle Speed Contr.Throttle Pos. Adaptation Malfunction
113	P2123 17	Throttle/Pedal Position Sensor/Switch "D" Circuit High
114	P2122 16	Throttle/Pedal Position Sensor/Switch "D" Circuit Low
115	P2138 29	Throttle/Pedal Position Sensor/Switch "D"/"E" Voltage Correlation
116	P2128 17	Throttle/Pedal Position Sensor/Switch "E" Circuit High
117	P2127 16	Throttle/Pedal Position Sensor/Switch "E" Circuit Low
118	P0606 94	ECM/PCM Processor
119	P0606 92	ECM/PCM Processor
120	P2106 29	Throttle Actuator Control System Forced Limited Power
121	P0606 64	ECM/PCM Processor
122	P0606 61	ECM/PCM Processor
123	P0606 67	ECM/PCM Processor
124	P0606 1C	ECM/PCM Processor
125	P0606 55	ECM/PCM Processor
126	P0606 00	ECM/PCM Processor
127	P0606 62	ECM/PCM Processor

© CFMOTO Powersports, Inc. This manual is subject to all applicable copyright laws. Reproduction or duplication in any form, whole or in part, is strictly prohibited.

## 08 Electrical System

128	P0606 96	function monitoring: fault of ECU ADC - Null Load Test Pulse
129	P0606 97	function monitoring: fault of ECU ADC - test voltage
130	P0606 47	function monitoring: fault of ECU monitoring module error
131	P0606 17	Reported OverVoltage of VDD5
132	P0606 16	Reported UnderVoltage of VDD5
133	P0606 49	Diagnostic fault check to report "WDA active"
134	P0606 48	Diagnostic fault check to report "WDA active" due to errors in query-/response communication
135	P0606 91	Diagnostic fault check to report "WDA active" due to overvoltage detection
136	P0053 1E	O2 Sensor Heater Resistance Bank 1 Sensor 1
137	P0059 1E	O2 Sensor Heater Resistance Bank 2 Sensor 1
138	P0030 13	O2 Sensor Heater Control Circuit Bank 1 Sensor 1
139	P0031 11	O2 Sensor Heater Control Circuit Low Bank 1 Sensor 1
140	P0032 12	O2 Sensor Heater Control Circuit High Bank 1 Sensor 1
141	P0050 13	O2 Sensor Heater Control Circuit Bank 2 Sensor 2
142	P0051 11	O2 Sensor Heater Control Circuit Low Bank 2 Sensor 1
143	P0052 12	O2 Sensor Heater Control Circuit High Bank 2 Sensor 1
144	P0130 29	O2 Sensor Circuit Bank 1 Sensor 1
145	P0131 16	O2 Sensor Circuit Low Voltage Bank 1 Sensor 1
146	P0132 17	O2 Sensor Circuit High Voltage Bank 1 Sensor 1
147	P0133 00	O2 Sensor Circuit Slow Response Bank 1 Sensor 1
148	P0134 13	O2 Sensor Circuit No Activity Detected Bank 1 Sensor 1
149	P0150 29	O2 Sensor Circuit Bank 2 Sensor 1
150	P0151 16	O2 Sensor Circuit Low Voltage Bank 2 Sensor 1
151	P0152 17	O2 Sensor Circuit High Voltage Bank 2 Sensor 1
152	P0153 00	O2 Sensor Circuit Slow Response Bank 2 Sensor 1
153	P0154 13	O2 Sensor Circuit No Activity Detected Bank 2 Sensor 1
154	P2177 00	System Too Lean Off Idle bank1
155	P2178 00	System Too Rich Off Idle bank1
156	P2179 00	System Too Lean Off Idle bank2
157	P2180 00	System Too Rich Off Idle bank2
158	U0073 88	Control Module Communication Bus Off
159	U0140 87	Lost Communication With Body Control Module
160	U0121 87	Lost Communication With Anti-Lock Brake System (ABS) Control Module
161	U0155 87	Lost Communication With Instrument Panel Cluster (IPC) Control Module
162	U0198 87	Lost Communication With Gateway "A"
163	U0131 87	Lost Communication With Power Steering Control Module
164	P062F 42	Internal Control Module EEPROM Error
165	P062F 43	Internal Control Module EEPROM Error
166	P1610 00	Manufacturer controlled computer and auxiliary outputs
167	P1611 00	Manufacturer controlled computer and auxiliary outputs
168	P1612 00	Manufacturer controlled computer and auxiliary outputs
169	P1613 00	Manufacturer controlled computer and auxiliary outputs
170	P1614 00	Manufacturer controlled computer and auxiliary outputs
171	P01980	roll-over switch fault

## 8.4 Fault Diagnosis and Treatment

### Engine Body:

Troubles	Possible Cause	Countermeasures
Cannot start or difficult to start	<p><b>Cylinder pressure too low</b></p> <ol style="list-style-type: none"> <li>1. Cylinder worn</li> <li>2. Piston ring worn</li> <li>3. Air leakage of cylinder gasket</li> <li>4. Valve stem worn or unsuitable valve seat</li> <li>5. Spark plug loosen</li> <li>6. Starting motor rotate too slowly</li> <li>7. Improper valve timing</li> <li>8. Improper valve clearance</li> </ol> <p><b>Spark plug cannot ignite or weak ignition</b></p> <ol style="list-style-type: none"> <li>1. Improper spark plug clearance</li> <li>2. Spark plug dirty or wet</li> <li>3. Defect ignition coil</li> <li>4. Trigger short circuit or open circuit</li> <li>5. Magneto malfunction</li> </ol> <p><b>Insufficient fuel inside throttle body</b></p> <ol style="list-style-type: none"> <li>1. Breather hole block</li> <li>2. Injector blocked or failure</li> <li>3. High Pressure oil pump failure</li> <li>4. Low pressure, oil pump</li> <li>5. Oil pump Filter net blocked</li> </ol>	<p>Replace</p> <p>Replace</p> <p>Replace</p> <p>Repair or replace</p> <p>Tighten</p> <p>Check electrical parts</p> <p>Adjust</p> <p>Adjust</p> <p>Adjust or replace</p> <p>Clean &amp; dry or replace</p> <p>Replace</p> <p>Replace</p> <p>Replace</p> <p>Clean or replace</p> <p>Clean or replace</p> <p>Inspect or replace</p> <p>Inspect or replace</p> <p>Clean or replace</p>
No idle speed or unstable speed	<ol style="list-style-type: none"> <li>1. Improper valve clearance</li> <li>2. Unsuitable valve seat</li> <li>3. Defective valve</li> <li>4. Rocker or rocker arm wear</li> <li>5. Dirty spark plug</li> <li>6. Incorrect valve clearance</li> <li>7. Ignition coil failure</li> <li>8. In &amp; Ex a air hose blocked, idle valve</li> <li>9. Magneto failure</li> </ol>	<p>Adjust</p> <p>Repair or replace</p> <p>Replace</p> <p>Replace</p> <p>Replace</p> <p>Replace or adjust</p> <p>Replace</p> <p>Adjust or replace</p> <p>Replace</p>

## 08 Electrical System

© CFMOTO Powersports, Inc. This manual is subject to all applicable copyright laws. Reproduction or duplication in any form, whole or in part, is strictly prohibited.

Troubles	Possible Cause	Countermeasures
High RPM unstable	<ol style="list-style-type: none"> <li>1. Valve spring getting worn</li> <li>2. Camshaft worn</li> <li>3. Spark plug dirty</li> <li>4. Spark plug gap too narrow</li> <li>5. Valve timing incorrect</li> <li>6. Ignition coil failure</li> <li>7. Low pressure,oil pump</li> <li>8. Air filter too dirty</li> </ol>	<p>Replace                      Replace                      Clean or replace                      Adjust or replace                      Adjust                      Replace                      Adjust or replace                      Clean or replace</p>
Blue or black exhaust gas	<ol style="list-style-type: none"> <li>1. Engine oil too much</li> <li>2. Piston ring worn</li> <li>3. Valve worn</li> <li>4. Cylinder worn or scraped</li> <li>5. Valve stem worn</li> <li>6. Oil seal of valve stem damaged</li> </ol>	<p>Check oil level and drain                      Replace                      Replace                      Replace                      Replace                      Replace</p>
Engine Power not enough	<ol style="list-style-type: none"> <li>1. Valve clearance improper</li> <li>2. Valve spring getting weak</li> <li>3. Valve timing incorrect</li> <li>4. Cylinder worn</li> <li>5. Piston ring worn</li> <li>6. Improper valve seat</li> <li>7. Spark plug dirty</li> <li>8. Improper spark plug gap</li> <li>9. Injector blocked</li> <li>10. Insufficient pressure,oil pump</li> <li>11. Air filter too dirty</li> <li>12. Rocker arm or camshaft worn</li> <li>13. Air leakage of inlet pipe</li> <li>14. Engine oil too much</li> </ol>	<p>Adjust                      Replace                      Adjust                      Replace                      Replace                      Replace or repair                      Clean or replace                      Clean or replace                      Clean or replace                      Adjust or replace                      Clean or replace                      Replace                      Tighten or replace                      Check oil level and change</p>
Engine Overheating	<ol style="list-style-type: none"> <li>1. Carbon deposit on piston head</li> <li>2. Engine oil too less or too much</li> <li>3. Oil pump failure</li> <li>4. Fuel hose blocked</li> <li>5. Air leakage of inlet pipe</li> <li>6. Unsuitable engine oil</li> <li>7. Cooling system failure(see7-5)</li> </ol>	<p>Clean                      Check and add or drain                      Replace                      Clean                      Tighten or replace                      Change oil</p>

Troubles	Possible Cause	Countermeasures
Engine abnormal noise	<b>Valve abnormal noise</b> 1. Valve clearance too big 2. Valve spring worn or broken 3. Swing arm or camshaft worn	Adjust Replace Replace
	<b>Piston abnormal noise</b> 1. Piston worn 2. Cylinder worn 3. Carbon deposit inside combustion chamber 4. Piston pin or pin hole worn 5. Piston ring or groove worn	Replace Replace Clean Replace Replace
	<b>Timing chain abnormal noise</b> 1. Chain stretched out 2. Chain sprocket worn 3. Tensioner failure	Replace chain and sprocket Replace chain and sprocket Repair or replace
	<b>Clutch abnormal noise</b> 1. Clutch gear worn or damaged 2. Cushion rubber aging or damaged	Replace clutch gear Replace clutch gear
	<b>Crankshaft abnormal noise</b> 1. Bearing noise 2. Crankshaft pin bearing down 3. Clearance too big	Replace Replace Replace
	<b>Transmission abnormal noise</b> 1. Gear worn or damaged 2. Main shaft or counter shaft worn 3. Bearing worn 4. Bushing worn	Replace Replace Replace Replace
Clutch slippery	1. Clutch drive disc worn 2. Clutch driven disc worn or damaged 3. Clutch spring getting weak	Replace Replace Replace

## Ignition System:

Troubles	Possible Cause	Countermeasures
No spark or weak spark	1. Flame igniter malfunction 2. Spark plug burnt 3. Incorrect spark plug clearance 4. Carbon deposit in spark plug 6. Battery low voltage 7. Ignition coil malfunction 8. Trigger coil malfunction 9. Incorrect trigger clearance 10. Other circuit malfunction	Replace Replace Adjust Clean Replace Charge or replace Replace Replace Adjust Inspect

## 8.5 Trouble Diagnosis by Engine Error

Before trouble diagnosis by engine problems, initial checking should be done as follows.

1. Confirm if trouble light is ok.
2. Confirm there's no trouble code record by DSCAN checking.
3. Confirm there's really trouble existing complained by end-users.

**Then check the following points:**

1. Check fuel hoses if any fuel leakage.
2. Check vacuum pipes if any broken, twist or improper connection.
3. Check intake manifold if any blocked, air leakage or damaged.
4. Check high-tension cable if any damaged, aging or ignition order is correct.
5. Check wiring close to ground if it's clean and firm.
6. Check connector of all sensors and actuator if any loose or improper connection.

**Important note: In case there are some problems as above-mentioned, then removal work should be done firstly, then go to next diagnosis.**

**Diagnosis helps:**

1. Confirm engine without any trouble record.
2. Confirm there's really trouble existing.
3. During checking, do not neglect vehicle periodic maintenance, cylinder pressure, valve timing, fuel supply and so on.
4. Replace ECU to test.

In case trouble disappears, then it's a problem of ECU. If trouble still exists, then assemble original ECU and check other points.

**Frequent troubles list:**

- When starting the engine, engine cannot rotate or rotate slowly.
- When starting engine, starter motor can rotate but cannot start engine.
- Difficult to start warm or hot engine.
- Difficult to start cold engine .
- RPM is ok, but difficult to start engine.
- Starting is ok, but idle speed is unstable at any time.
- Starting is ok, but idle speed is unstable during engine warm-up period.
- Starting is ok, but idle speed is unstable after engine warm-up.
- Starting is ok, idle speed is unstable or engine stop when switch on some lights or other electric components.
- Starting is ok, but too high idle speed.
- RPM cannot go up or engine stop when acceleration.
- Slow acceleration.
- Insufficient power and bad performance when acceleration.

## (1) Starting Failure/Hard Starting

General failure part: 1. Battery; 2. Starter motor; 3. Wirings harness or ignition switch; 4. Engine mechanism part.

General diagnosis procedures:

Item	Procedures	Results	Next
1	Use multi-meter to check battery voltage if voltage is between 8-12V or not when engine starts.	YES	Next step
		NO	Replace battery
2	Turn on ignition switch, stop switch side stand switch and check if voltage of ECU pin 35 is around 12V.	YES	Next step
		NO	Repair switches or change harness
3	Keep ignition switch "on", use multi-meter to check if voltage of starting motor anode is over 8V.	YES	Next step
		NO	Repair switches or change harness
4	Disassemble starting motor and check its working status, especially whether there was broken circuit or jammed by bad lubrication.	YES	Repair or replace starting motor
		NO	Next step
5	If error only occur in Winter, check if starting motor resistance is too big caused by improper oil used.	YES	Change to proper lubricant
		NO	Next step
6	Check if mechanical resistance is too big inside engine.	YES	Check engine inside resistance
		NO	Repeat above procedures

## (2) When starting, engine can rotate but cannot start

General failure part: 1. No fuel; 2. Fuel pump; 3. Trigger; 4. Ignition coil; 5. Mechanical parts of engine

General diagnosis procedures:

Item	Procedures	Results	Next
1	Connect fuel pressure gauge, turn on ignition switch or start engine, check if fuel pressure is around 300kpa.	YES	Next step
		NO	Check and repair fuel supply system
2	Connect DSCAN, check if there's signal of RPM data after starting engine.	YES	Next step
		NO	Check and repair RPM sensor circuit
3	Disconnect high-tension cable, connect spark plug and set its electrode 5mm to engine body, then start engine to check if blue and white spark appears.	YES	Next step
		NO	Check and repair ignition system
4	Test cylinder pressure and check if pressure is enough.	YES	Eliminate engine mechanical failures
		NO	Next step
5	Use DSCAN to test, turn on ignition switch, check if power supply of ECU pin 35 and 20 is normal; check if pin 63, 64, 111 and 112 work normally.	YES	Use DSCAN to check
		NO	Repair related circuit

### (3) Difficult to start hot engine

General failure part: 1. Water in fuel tank; 2. Fuel pump; 3. Water temp. sensor; 4. Ignition coil.

General diagnosis procedures:

Item	Procedures	Results	Next
1	Connect fuel pressure gauge, turn on ignition switch or start engine, check if fuel pressure is around 300kpa.	YES	Next step
		NO	Check and repair fuel supply system
2	Disconnect high-tension cable, connect spark plug and set its electrode 5mm to engine body, then start engine to check if blue and white spark appears.	YES	Next step
		NO	Check and repair ignition system
3	Disconnect water temp. sensor connector, check whether the engine can be started or not. (Or replace water temp. sensor with a 300Ω resistance. Check whether the engine can be started or not.)	YES	Change fuel
		NO	Next step
4	Check whether the failure happens right after fueling.	YES	Use DSCAN to check
		NO	Repair related circuit
5	Use DSCAN to test, turn on ignition switch, check if power supply of ECU pin 35 and 20 is normal; check if pin 63, 64, 111 and 112 work normally.	YES	Use DSCAN to check
		NO	Repair related circuit

### (4) Difficult to start cold engine

General failure part: 1. Water in fuel tank; 2. Fuel pump; 3. Engine temp. sensor; 4. Injector; 5. Ignition coil; 6. Throttle body and by-pass; 7. Mechanical parts of engine

General diagnosis procedures:

Item	Procedures	Results	Next
1	Connect fuel pump gauge ,start engine, check if pressure is around 300kPa.	YES	Next step
		NO	Check and repair fuel supply system
2	Disconnect high-tension cable, connect spark plug and set its electrode 5mm to engine body, then start engine to check if blue and white spark appears.	YES	Next step
		NO	Check and repair ignition system
3	Disconnect water temp. sensor connector, check whether the engine can be started or not. (Or replace water temp. sensor with a 2500Ω resistance. Check whether the engine can be started or not.)	YES	Repair circuit or replace sensor
		NO	Next step
4	Slightly draw throttle cable and check if engine could start easily.	YES	Clean throttle body and by-pass
		NO	Next step
5	Disassemble injector and check if there is a leak or blockage.	YES	Replace injector
		NO	Next step
6	Check whether the failure happens right after filling fuel.	YES	Change fuel
		NO	Next step
7	Check if cylinder pressure is insufficient.	YES	Eliminate engine mechanical failures
		NO	Next step

# CFMOTO

## (5) Difficult to start in any conditions

General failure part: 1. Water in fuel tank; 2. Fuel pump; 3. Injector; 4. Ignition coil; 5. Throttle body and by-pass; 6. Air intake pipe; 7. Ignition timing; 8. Spark plug; 9. Mechanical part of engine

General diagnosis procedures:

Item	Procedures	Results	Next
1	Check if air filter is blocked or air intake pipe leaks.	YES	Check and repair air intake system
		NO	Next step
2	Connect fuel pump gauge, start engine, check if pressure is around 330kPa.	YES	Next step
		NO	Check and repair fuel supply system
3	Disconnect high-tension cable, connect spark plug and set its electrode 5mm to engine body, then start engine to check if blue and white spark appears.	YES	Next step
		NO	Check and repair ignition system
4	Check if spark plug is suitable for requirement including its type and clearance.	YES	Next step
		NO	Adjust or replace
5	Disconnect water temp. sensor connector, check whether the engine can be started or not.	YES	Repair circuit or replace sensor
		NO	Next step
6	Slightly draw throttle cable and check if engine could start easily.	YES	Clean throttle body and by-pass
		NO	Next step
7	Disassemble injector and check if there is a leak or blockage.	YES	Replace
		NO	Next step
8	Check whether the failure happens right after filling fuel.	YES	Change fuel
		NO	Next step
9	Check if cylinder pressure is insufficient.	YES	Eliminate engine mechanical failures
		NO	Next step

## (6) Normal starting, but unstable idle speed

General failure part: 1. Water in fuel tank; 2. Injector; 3. Spark plug; 4. Throttle body and by-pass; 5. Air intake pipe; 6. Air control valve; 7. Ignition timing; 8. Spark plug; 9. Mechanical part of engine

General diagnosis procedures:

Item	Procedures	Results	Next
1	Check if air filter is blocked or air intake pipe leaks.	YES	Check and repair air intake system
		NO	Next step
2	Check if air control valve is blocked.	YES	Clean or replace
		NO	Next step
3	Check if spark plug is suitable for requirement including its type and clearance.	YES	Next step
		NO	Adjust or replace
4	Check if there is carbon deposit inside throttle body and air control valve.	YES	Clean
		NO	Next step
5	Disassemble injector and check if there is a leak or blockage.	YES	Replace
		NO	Next step
6	Check whether the failure happens right after fueling.	YES	Change fuel
		NO	Next step
7	Check if cylinder pressure is insufficient.	YES	Eliminate engine mechanical failures
		NO	Next step
8	Check if ignition timing complies with standard regulation.	YES	Next step
		NO	Check and repair ignition timing

## (7) Normal starting, but unstable idle speed during engine warming

General failure part: 1. Water in fuel tank; 2. Injector; 3. Spark plug; 4. Throttle body and by-pass; 5. Air intake pipe; 6. Air control valve; 7. Mechanical part of engine

General diagnosis procedures:

Item	Procedures	Results	Next
1	Check if air filter is blocked or air intake pipe leaks.	YES	Check and repair air intake system
		NO	Next step
2	Check if spark plug is suitable for requirement including its type and clearance.	YES	Next step
		NO	Adjust or replace
3	Check if there is carbon deposit inside throttle body and air control valve.	YES	Clean
		NO	Next step
4	Disconnect water temp. sensor connector and start engine to check idle speed is stable or not.	YES	Repair circuit or replace sensor
		NO	Next step
5	Disassemble injector and check if there is a leak or blockage.	YES	Replace
		NO	Next step
6	Check whether the failure happens right after fueling.	YES	Change fuel
		NO	Next step
7	Check if cylinder pressure is insufficient.	YES	Eliminate engine mechanical failures
		NO	Next step

## (8) Normal starting, but unstable idle speed after engine warming

General failure part: 1. Water in fuel tank; 2. Injector; 3. Spark plug; 4. Throttle body and by-pass; 5. Air intake pipe; 6. Air control valve; 7. Mechanical part of engine

General diagnosis procedures:

Item	Procedures	Results	Next
1	Check if air filter is blocked or air intake pipe leaks.	YES	Check and repair air intake system
		NO	Next step
2	Check if spark plug is suitable for requirement including its type and clearance.	YES	Next step
		NO	Adjust or replace
3	Check if there is carbon deposit inside throttle body and air control valve.	YES	Clean
		NO	Next step
4	Disconnect water temp. sensor connector and start engine to check idle speed is stable or not.	YES	Repair circuit or replace sensor
		NO	Next step
5	Disassemble injector and check if there is a leak or blockage.	YES	Replace
		NO	Next step
6	Check whether the failure happens right after filling fuel.	YES	Change fuel
		NO	Next step
7	Check if cylinder pressure is insufficient.	YES	Eliminate engine mechanical failures
		NO	Next step

### (9) Normal starting, unstable idle speed or engine stop when it is electronic loaded (e.g. headlight is on)

General failure part: 1. Air control valve; 2. Injector

General diagnosis procedures:

Item	Procedures	Results	Next
1	Disassemble air control valve and check if there is carbon deposit inside throttle body, idle adjustment and by-pass.	YES	Clean
		NO	Next step
2	Check if output power increases when lighting, by using DSCAN to test if ignition advance angle, fuel spray and air intake volume is normal.	YES	Next step
		NO	Next step
		NO	Repair air intake system
3	Disassemble injector and check for leaks, blockages or improper fuel flow.	YES	Replace
		NO	Next step
4	Use DSCAN to test, turn on ignition switch, check if power supply of ECU pin 35 and 20 is normal; check if pin 63, 64, 111 and 112 work normally.	YES	Use DSCAN to check
		NO	Repair related circuit

### (10) Engine starts normally, but idle speed is too high

General failure part: 1. Throttle body and by-pass; 2. Injector seat; 3. Air control valve; 4. Water temp. sensor; 5. Ignition timing

General diagnosis procedures:

Item	Procedures	Results	Next
1	Check if throttle cable is jammed or too tight.	YES	Adjust
		NO	Next step
2	Check if air filter is blocked or air intake pipe leaks.	YES	Check and repair air intake system
		NO	Next step
3	Check if there is carbon deposit inside throttle body and air control valve.	YES	Clean
		NO	Next step
4	Remove water temp. sensor connector, start engine to check if idle speed is too high.	YES	Repair wiring or replace sensor
		NO	Next step
5	Check if ignition timing complies with standard regulation.	YES	Next step
		NO	Check and repair ignition timing

# CFMOTO

## (11) RPM cannot increase or engine stop when accelerating

General failure part: 1. Water in fuel tank; 2. TPS; 3. Spark plug; 4. Throttle body and by-pass; 5. Air intake pipe; 6. Air control valve; 7. Injector; 8. Ignition timing; 9. Exhaust pipe

General diagnosis procedures:

Item	Procedures	Results	Next
1	Check if air filter is blocked.	YES	Check and repair air intake system
		NO	Next step
2	Connect fuel pressure gauge, turn on ignition switch or start engine, check if fuel pressure is around 250kpa.	YES	Next step
		NO	Check and repair fuel supply system
3	Check if spark plug is suitable for requirement including its type and clearance.	YES	Next step
		NO	Adjust or replace
4	Remove air control valve and check if there is carbon deposit inside throttle body, air control valve and by-pass.	YES	Clean
		NO	Next step
5	Check if T PS and its circuit is normal.	YES	Next step
		NO	Repair wiring or replace sensor
6	Disassemble injector and check if there is a leak or blockage.	YES	Replace
		NO	Next step
7	Check whether the failure happens right after filling fuel.	YES	Change fuel
		NO	Next step
8	Check if ignition timing complies with standard regulation.	YES	Next step
		NO	Check and repair ignition timing
9	Check if exhaust gas exhale smoothly.	YES	Next step
		NO	Repair or replace exhaust pipe

## (12) Low acceleration

General failure part: 1. Water in fuel tank; 2. TPS; 3. Spark plug; 4. Throttle body and by-pass; 5. Air intake pipe; 6. Air control valve; 7. Injector; 8. Ignition timing; 9. Exhaust pipe

General diagnosis procedures:

Item	Procedures	Results	Next
1	Check if air filter is blocked.	YES	Check and repair air intake system
		NO	Next step
2	Connect fuel pressure gauge, turn on ignition switch or start engine, check if fuel pressure is around 300kpa.	YES	Next step
		NO	Check and repair fuel supply system
3	Check if spark plug is suitable for requirement including its type and clearance.	YES	Next step
		NO	Adjust or replace
4	Remove air control valve and check if there is carbon deposit inside throttle body, air control valve and by-pass.	YES	Clean
		NO	Next step

## 08 Electrical System

Item	Procedures	Results	Next
5	Check if TPS and its circuit is normal.	YES	Next step
		NO	Repair wiring or replace sensor
6	Disassemble injector and check if there is a leak or blockage.	YES	Replace
		NO	Next step
7	Check whether the failure happens right after filling fuel.	YES	Change fuel
		NO	Next step
8	Check if ignition timing complies with standard regulation.	YES	Next step
		NO	Check and repair ignition timing
9	Check if exhaust gas exhale smoothly.	YES	Next step
		NO	Repair or replace exhaust pipe

## (13) Difficult to accelerate and bad performance

General failure part: 1. Water in fuel tank; 2. TPS; 3. Spark plug; 4. Ignition coil; 5. Throttle body and by-pass; 6. Air intake pipe; 7. Air control valve; 8. Injector; 9. Ignition timing; 10. Exhaust pipe

General diagnosis procedures:

Item	Procedures	Results	Next
1	Check if clutch sliding, low tire pressure, bad brake or wrong tire size.	YES	Repair
		NO	Next step
2	Check if air filter is blocked.	YES	Check and repair air intake system
		NO	Next step
3	Connect fuel pressure gauge, turn on ignition switch or start engine, check if fuel pressure is around 300kpa.	YES	Next step
		NO	Check and repair fuel supply system
4	Disconnect high-tension cable, connect spark plug and set its electrode 5mm to engine body, then start engine to check if spark is strong enough.	YES	Next step
		NO	Check and repair ignition timing
5	Check if spark plug is suitable for requirement including its type and clearance.	YES	Next step
		NO	Replace
6	Remove air control valve and check if there is carbon deposit inside throttle body, air control valve and by-pass.	YES	Clean
		NO	Next step
7	Check if T PS and its circuit is normal.	YES	Next step
		NO	Repair wiring or replace sensor
8	Disassemble injector and check if there is a leak or blockage.	YES	Replace
		NO	Next step
9	Check whether the failure happens right after filling fuel.	YES	Change fuel
		NO	Next step
10	Check if ignition timing complies with standard regulation.	YES	Next step
		NO	Check and repair ignition timing
11	Check if exhaust gas exhale smoothly.	YES	Next step
		NO	Repair or replace exhaust pipe

9.1 Cooling System Diagram .....	2
9.2 Cooling System Removal .....	3
9.3 Coolant .....	4
9.4 Seal Inspection .....	4
9.5 Radiator and Water Pipes .....	5
9.6 Fan Motor Inspection .....	6
9.7 Coolant Inspection .....	6
9.8 Coolant Addition.....	6
9.9 Coolant Replacement.....	7

## 9.1 Cooling System Diagram

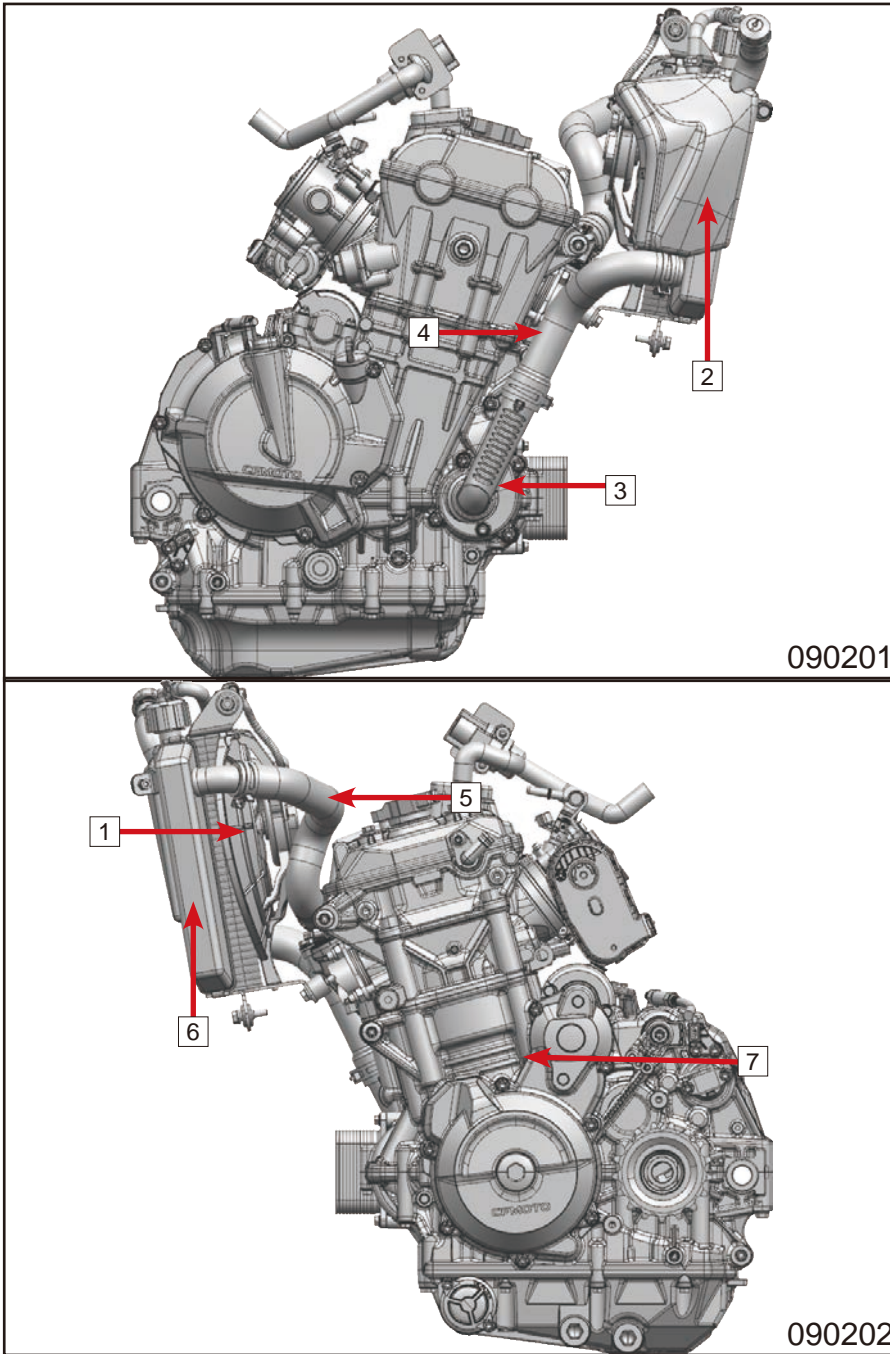

**⚠ DANGER:**

Coolant is toxic. Don't drink nor spill on skin, eyes, clothing. If coolant is swallowed, induce vomit and seek for medical attention. If you get coolant on your skin or in your eyes, immediately wash it off before medical attention. If you spill coolant on your clothing, change your clothing.

Rusting and corroding residues in engine and radiator must be treated according to regulations. The chemical inside can do harm to humans.

**⚠ CAUTION:**

If tap water is added to the cooling system, scale deposit will accumulate inside the cooling system. When the temperature is below zero, ice will be generated, which will seriously affect the operation of the cooling system.

Antifreeze is added anti-rust agent and antiseptic. When it is diluted, it will lose resistance of rust and corrosion. The dilution concentration of antifreeze must be consistent with the manufacturer's instructions.

The coolant added into the cooling system is green and contains ethylene glycol. When the ambient temperature is at  $-35^{\circ}\text{C}$ , please choose the coolant whose freezing point is lower than  $-35^{\circ}\text{C}$ .

**⚠ WARNING:**

The coolant will be very hot and under pressure when the vehicle is running.

Never open the radiator cap when the engine is still hot. Otherwise, the vapor or hot coolant will cause injury.

If get scalded, rinse the wound with flowing cold water for more than 10 minutes until the wound is no longer painful and seek medical advice immediately.

## 9.2 Cooling System Removal

Place a container under water pump.

Remove drain bolt **1**.

Drain coolant.

Loosen clamp **2**.

Remove water outlet pipe **3**.

**NOTE:** After water outlet pipe removal, there is still some coolant spilling out.

**NOTE:** There is pressure inside cooling system. The coolant will spill out after removing drain bolt.

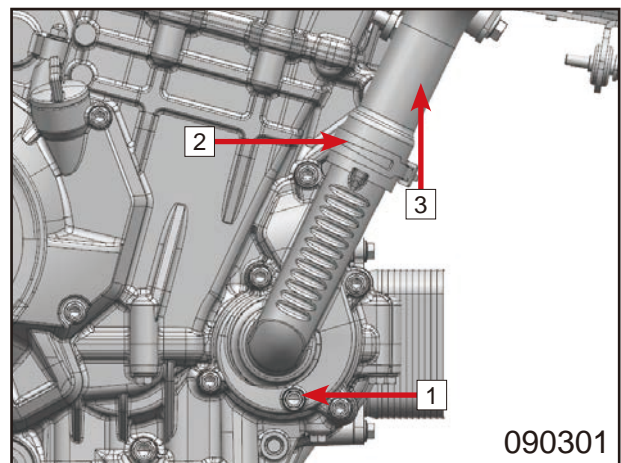

Loosen clamp **4**.

Remove water inlet pipe **5**.

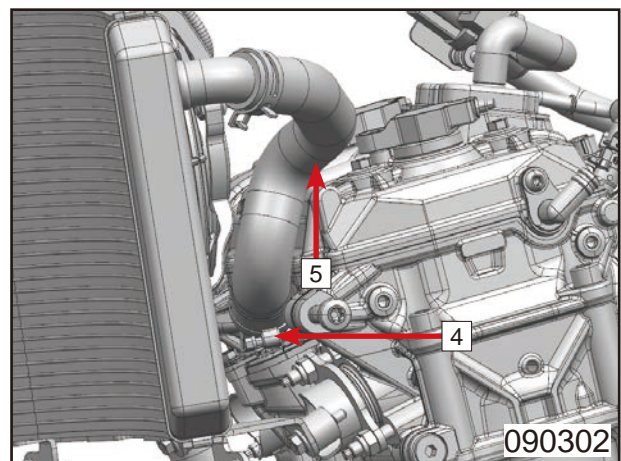

Remove two bolts **1**.

Remove bolt **2**.

Remove radiator **3**.

## Installation

Reverse the removal procedures for installation.

## 9.3 Coolant

Coolant in cooling system is a mixture of 51.5% distilled water, 46% ethylene glycol antifreeze and 2.5% additive. This mixture ratio provides optimized corrosion resistance and fine heat production. The mixture has good anti-corrosion and endothermic function, and its solidification point is  $-35^{\circ}\text{C}$ . If engine works under  $-35^{\circ}\text{C}$ , choose coolant of 40% or 50%.

**⚠ CAUTION:**  
**Use high quality ethylene glycol base antifreeze mixed with distilled water. Never mix alcohol base anti-freeze or other different brands of antifreeze.**  
**The ratio of mixture should not be more than 60% or less than 50%.**  
**Do not use anti-leak additive.**

CFMOTO coolant is an Organic Acid Technology (OAT) formula. When replenishing or replacing coolant, verify the label states 'compatible with one or more of the following formulas: OAT or Si-OAT, G30, G40, G12++'

## 9.4 Seal Inspection

### Radiator Cap Inspection

Remove radiator cap.

Measure the open pressure of radiator cap with pressure gauge.

If the pressure is out of standard, replace a new part.

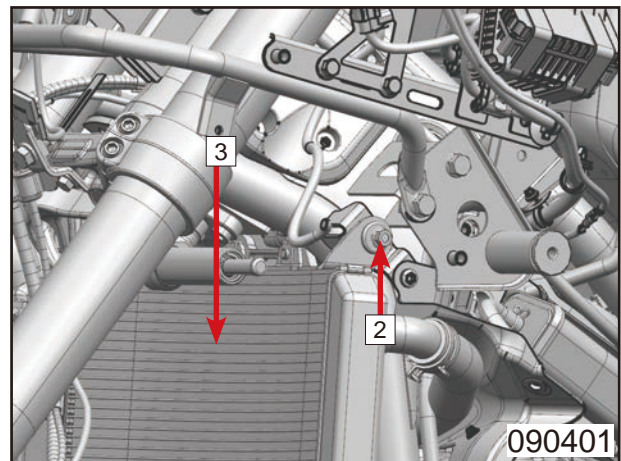
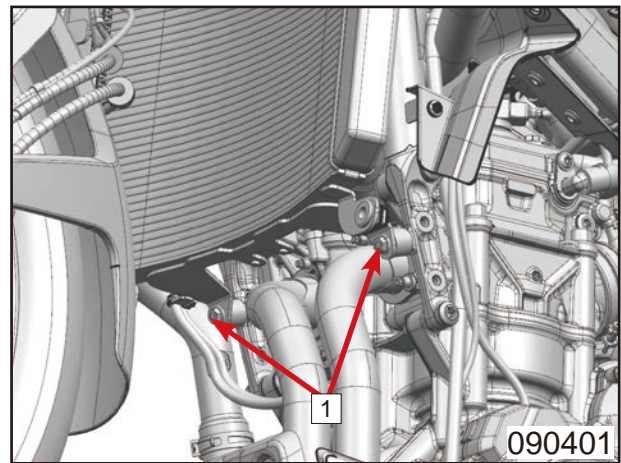

Mixing ratio	Freezing point
50%	$-30^{\circ}\text{C}$
55%	$-40^{\circ}\text{C}$
60%	$-55^{\circ}\text{C}$

## Radiator Cap Open Pressure:

135kPa~160kPa

1.35kgf/cm<sup>2</sup>~1.6kgf/cm<sup>2</sup>

19.58psi~23.2psi

## Standard:

140kPa

1.4kgf/cm<sup>2</sup>

20.3psi

## Seal Inspection

Connect the pressure gauge with reservoir joint.

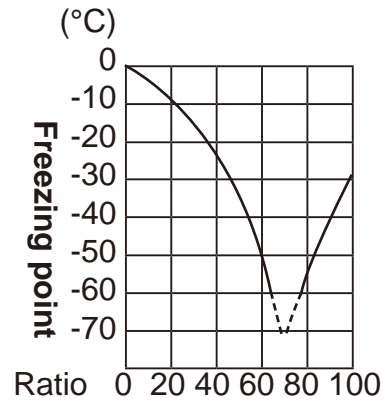

**⚠ WARNING: Never open the radiator cap when the engine is still hot. Otherwise, the vapor or hot coolant will cause injury.**

Inflate to 135 kPa, and last for 10s.

If the pressure decreases within 10s, there is leaking inside the system. Inspect the whole system and replace the broken parts.

**NOTE: When remove the gauge, cover radiator cap with cloth, in case the coolant spills out.**

**NOTE: The testing pressure does not exceed the open pressure.**

## 9.5 Radiator and Water Pipes

### Inspection and Clean

Remove dirt and dust from the radiator with high-pressure air.

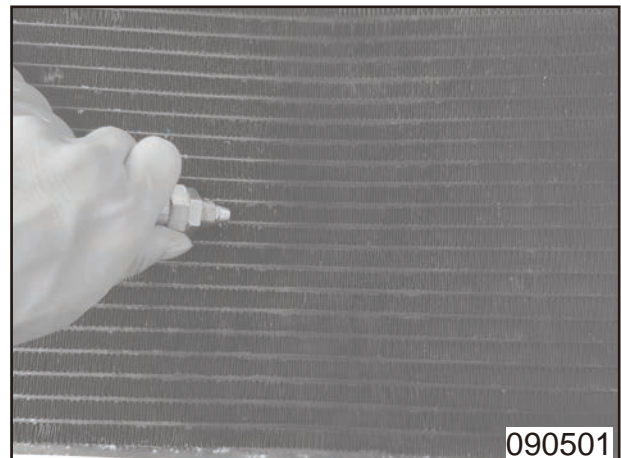

Repair radiator fins with a small screwdriver.

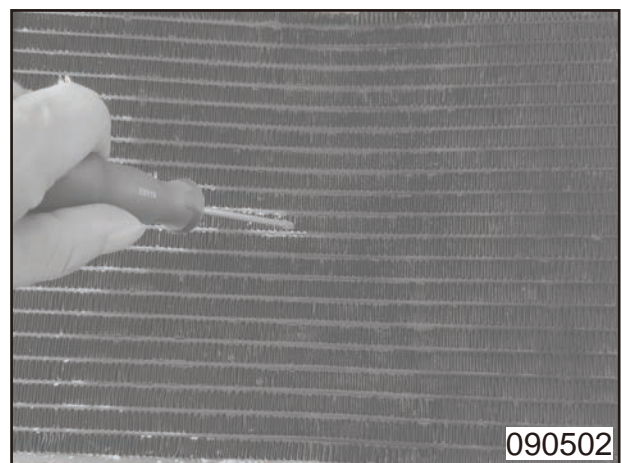

### Radiator Water Pipes Inspection

Inspect radiator water pipes for leakage, damage. Replace if necessary.

Inspect radiator water pipe clamps. Replace if loose.

After radiator and water pipes inspection, inspect the coolant. Add coolant if necessary.

## 9.6 Fan Motor Inspection

Remove bolts [1].

Remove fan motor assy [2].

Rotate impeller to check performance. Replace fan motor assy if stuck or other defect is found.

Battery voltage is 12V, make motor work, the electrical current is no more than 5A. Replace if motor doesn't work or current exceeds.

### Installation

Reverse the removal procedures for installation.

## 9.7 Coolant Inspection

Support the vehicle upright on level ground. Make sure the coolant completely cools down and check coolant level.

If the level locates A area, drain coolant until the level is at B area.

If the level locates B area, it is appropriate.

If the level locates C area, add coolant until the level is at B area.

**⚠ WARNING: The coolant temperature is very high and compressed as well when the vehicle is running. Do not open radiator, radiator hose, reservoir tank or other cooling system part before engine or cooling system completely cools down. Once scalding occurs, rinse the wound with running cold water for at least 10 minutes until the wound is no longer painful. Seek for medical treatment in time.**

## 9.8 Coolant Addition

Open reservoir tank cap and add coolant until level is at B area.

**⚠ CAUTION: If the coolant needs to be refilled frequently, or the coolant in the secondary tank is often sucked up and drained, the cooling system may leak. Contact your dealer to check the cooling system.**

It is only recommended to use the original coolant of CFMOTO. Different coolant mixing may cause engine damage. Contact your dealer to replace the coolant.

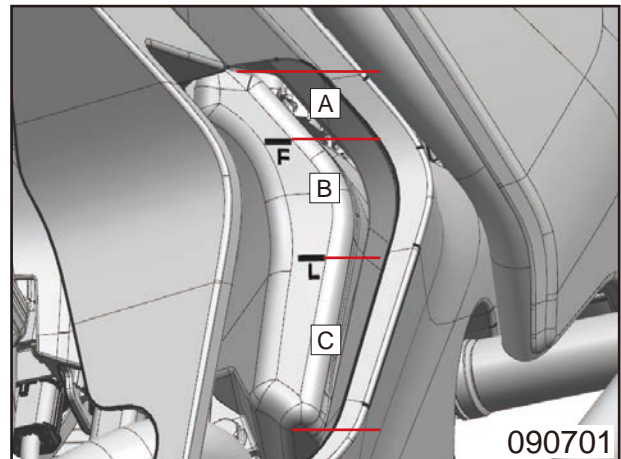
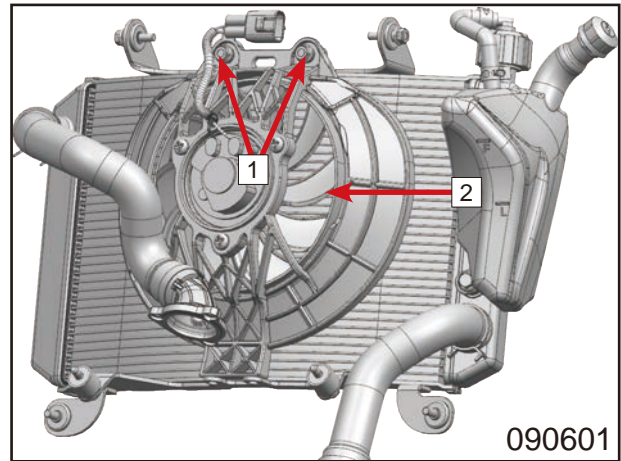

## 9.9 Coolant Replacement

Support the vehicle upright on level ground.  
Put a pen under water pump.  
Remove drain bolt **1** and drain coolant.  
Install drain bolt.

Open radiator cap **2**.  
Add coolant.  
Loosen drain bolt. Tighten drain bolt until the coolant flow is stable.  
Add coolant until it reaches radiator filling port.  
Install radiator cap.  
Open reservoir cap and add the same coolant until the level is at B area.  
Install reservoir tank cap.  
Make engine idling for 2~3 minutes.  
Check coolant level again after engine cools down.

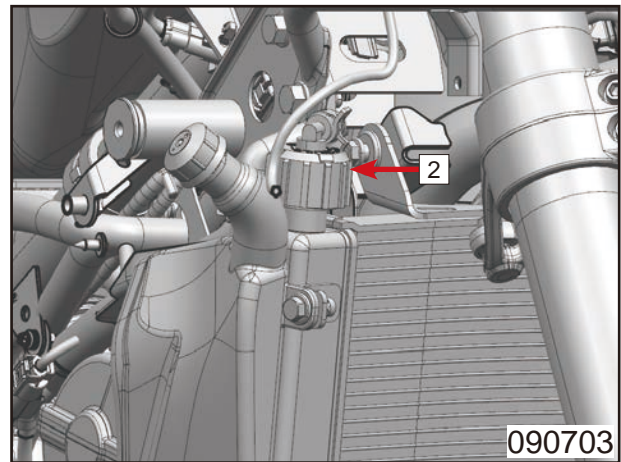
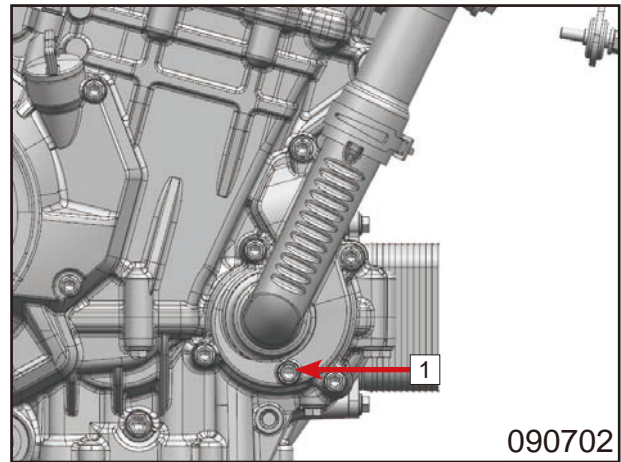

<b>10.1 Muffler Removal.....</b>	<b>2</b>
10.1.1 Engine Panels .....	2
10.1.2 Exhaust Pipe .....	3
10.1.3 Rear Muffler Body.....	4
10.1.4 Front Muffler Body.....	4
<b>10.2 Muffler Inspection.....</b>	<b>6</b>

© CFMOTO Powersports, Inc. This manual is subject to all applicable copyright laws. Reproduction or duplication in any form, whole or in part, is strictly prohibited.

**⚠ DANGER:** The temperature of muffler is very high after engine runs for a while. Do not park the vehicle near inflammable and explosive articles when removing muffler. Never operate high temperature parts like muffler when the vehicle isn't cool down, in case of burnt issue. The muffler will emit toxic and hazardous gas. Do not operate in a closed or no effective ventilation environment. The poisonous and harmful gas emitted by the muffler may cause poisoning or even death.

© CFMOTO Powersports, Inc. This manual is subject to all applicable copyright laws. Reproduction or duplication in any form, whole or in part, is strictly prohibited.

## 10.1 Muffler Removal

### 10.1.1 Engine Panels

Remove inner hex bolts **1**.  
Remove engine RH panel **2**.

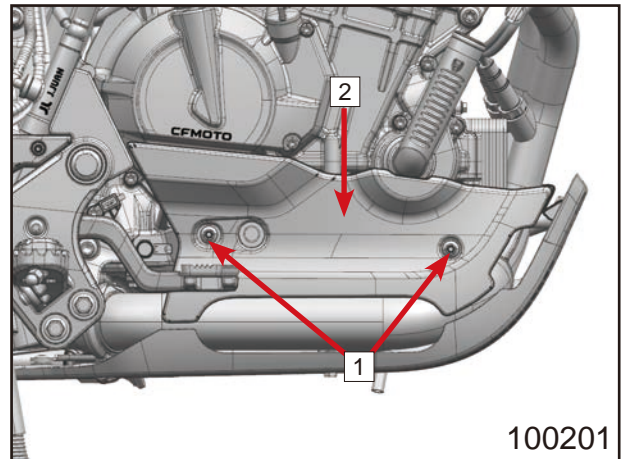

Remove inner hex bolts **3**.  
Remove engine LH panel **4**.

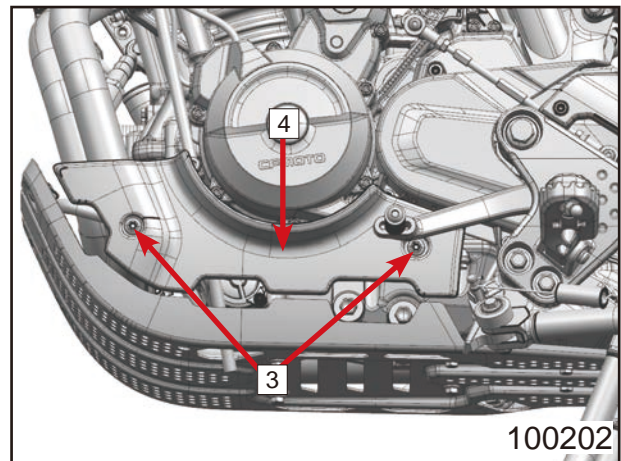

Remove bolts and washers **5**.  
Remove inner hex bolts **6**.  
Remove engine lower panel **7**.

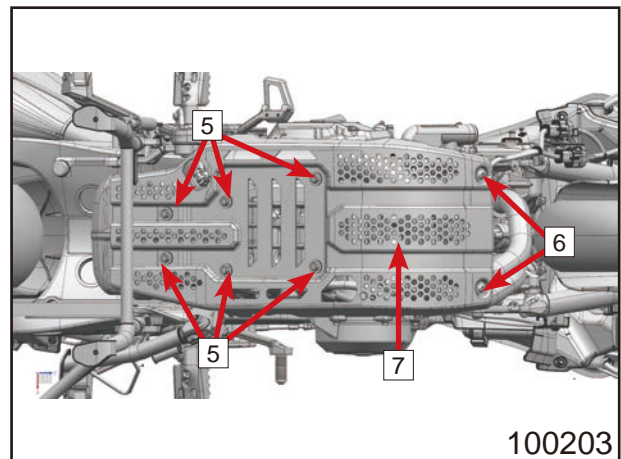

# 10 Muffler Assy

Remove inner hex bolts **8**.  
Remove bumper.

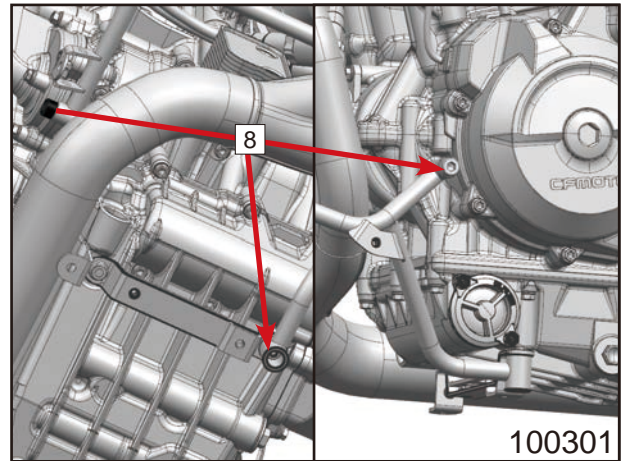

## 10.1.2 Exhaust Pipe

Unplug oxygen sensor connectors **1**.

**NOTE: The marks "L" and "R" on oxygen sensors align with joints.**

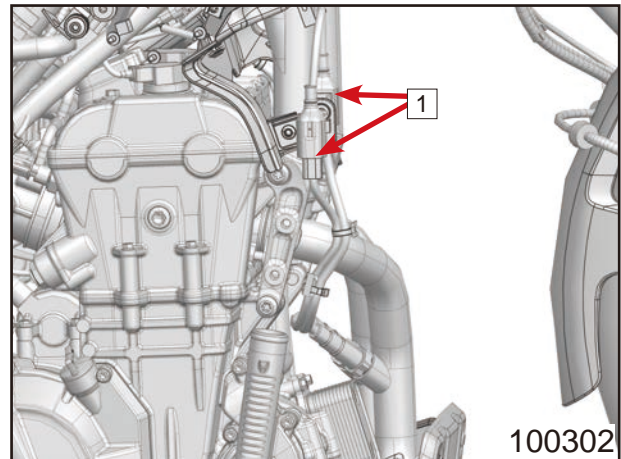

Remove lock nuts **2**.

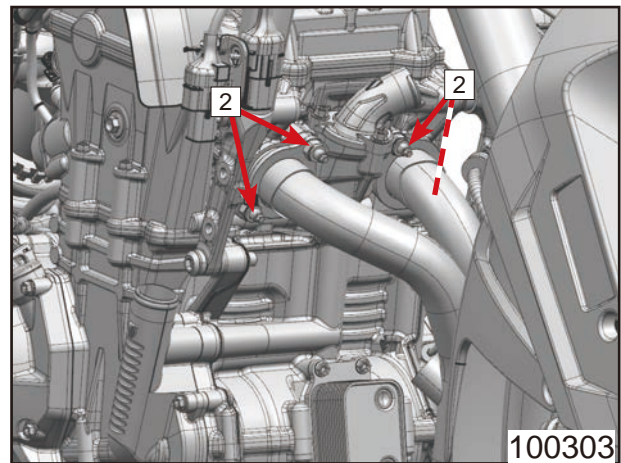

Loosen clamp **3**.

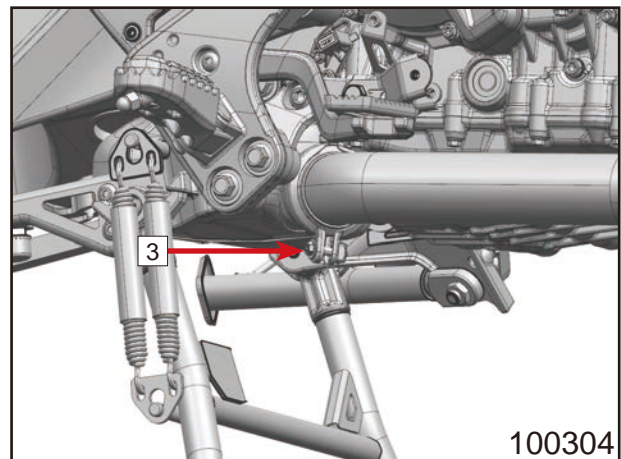

© CFMOTO Powersports, Inc. This manual is subject to all applicable copyright laws. Reproduction or duplication in any form, whole or in part, is strictly prohibited.

Remove exhaust pipe [4].

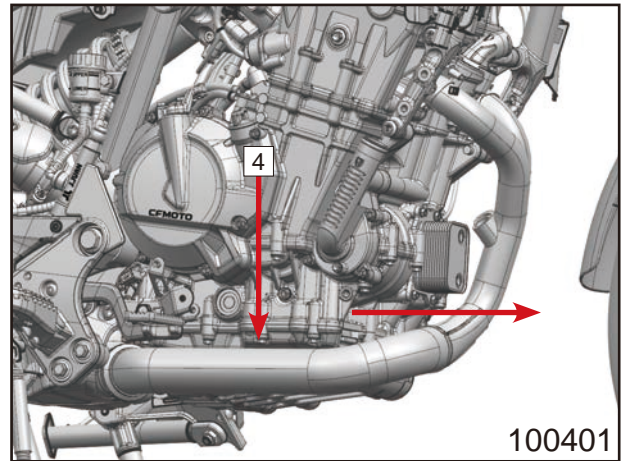

### 10.1.3 Rear Muffler Body

Loosen clamp [1].

Remove inner hex bolt [2].

Remove rear muffler body [3].

**NOTE: Hold muffler body during removal to avoid it dropping.**

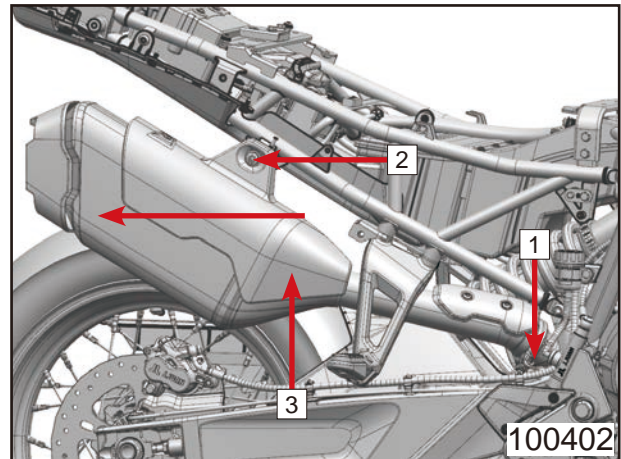

### 10.1.4 Front Muffler Body

Remove inner hex bolts [1].

Remove RH footrest bracket panel [2].

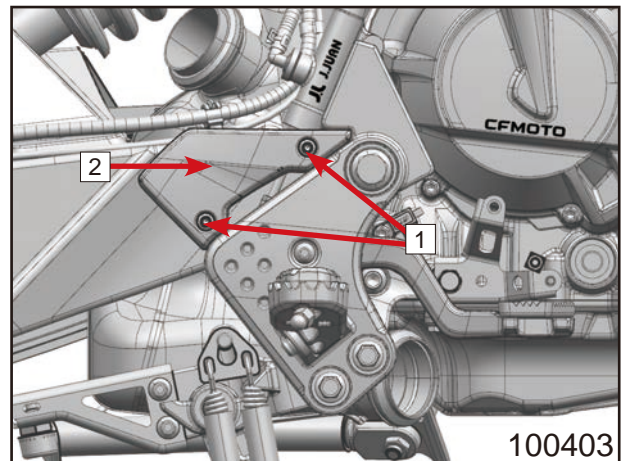

Remove bolt [3].

Remove bolts [4].

Hang RH footrest bracket [5] on the side.

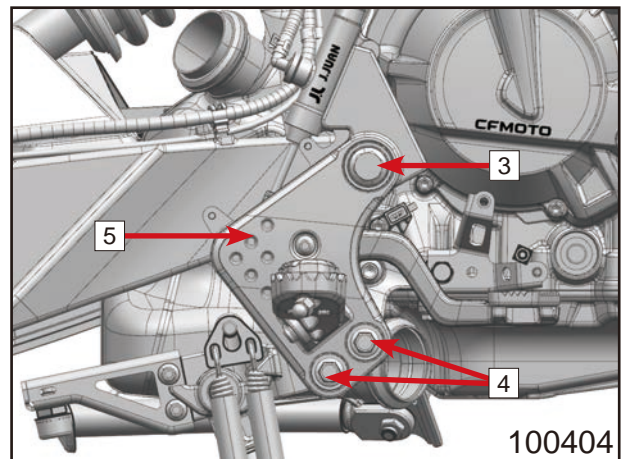

## 10 Muffler Assy

Remove bolt and washer 1 on right side.

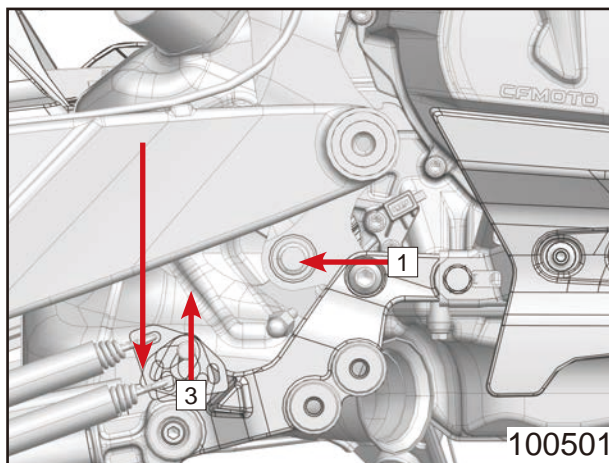

Remove bolt and washer 2 on left side.  
Remove front muffler body 3.

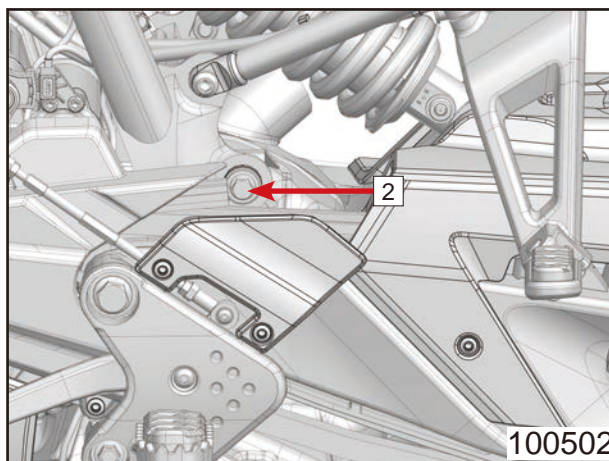

© CFMOTO Powersports, Inc. This manual is subject to all applicable copyright laws. Reproduction or duplication in any form, whole or in part, is strictly prohibited.

## 10.2 Muffler Inspection

Inspect muffler appearance for any defect. Replace if necessary.

Inspect muffler graphite ring seal sleeve I **1**.

Inspect two muffler gaskets **2**.

Inspect for cracks or damage. Replace if any defect is found.

Inspect three damping sleeves **3** for cracks, rust or other damage. Replace if any defect is found.

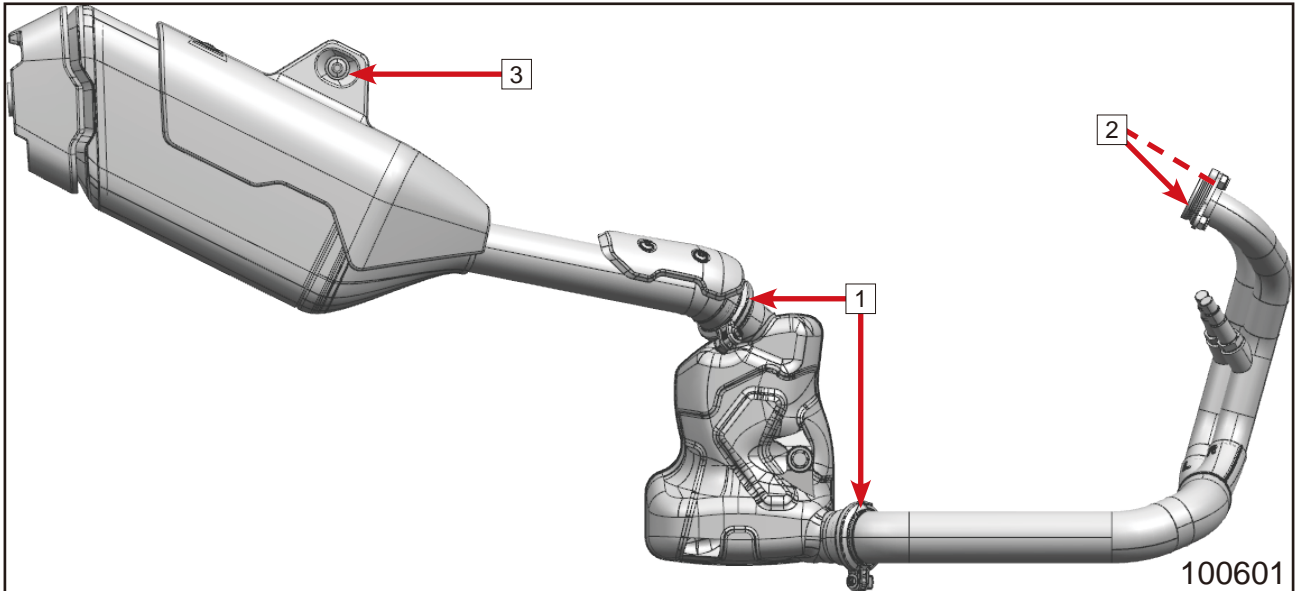

---

# 11 Wheels and Brake System

<b>11.1 Front Brake Caliper .....</b>	<b>2</b>
<b>11.2 Front Wheel .....</b>	<b>2</b>
<b>11.3 Rear Wheel .....</b>	<b>3</b>
<b>11.4 Rear Brake Caliper.....</b>	<b>4</b>
<b>11.5 Brake Master Cylinder .....</b>	<b>5</b>
<b>11.6 ABS Actuator.....</b>	<b>5</b>
<b>11.7 Hand Brake Master Cylinder Assy .....</b>	<b>6</b>
<b>11.8 Wheel Inspection .....</b>	<b>6</b>
11.8.1 Front Wheel .....	6
11.8.2 Rear Wheel .....	7
11.8.3 Tire Pressure.....	8
11.8.4 Tire Appearance.....	8
11.8.5 Wheel Bearing.....	9
11.8.6 Rim.....	9
<b>11.9 Brake System Inspection.....</b>	<b>10</b>
11.9.1 Hand Master Cylinder Inspection.....	10
11.9.2 Rear Master Cylinder Inspection .....	11
11.9.3 Brake Hose Inspection.....	13
11.9.4 Brake Calipers and Brake discs Inspection .....	13
<b>11.10 Free Play .....</b>	<b>14</b>
11.10.1 Front Brake Lever Free Play .....	14
11.10.2 Rear Brake Pedal Free Play .....	14

**NOTE:** Before removing wheels, support vehicle with bracket or other device to make tires off the ground.

## 11.1 Front Brake Caliper

Remove inner hex bolt [1].

Remove speed sensor [2].

Remove inner hex bolts [3].

Remove LH front brake caliper [4].

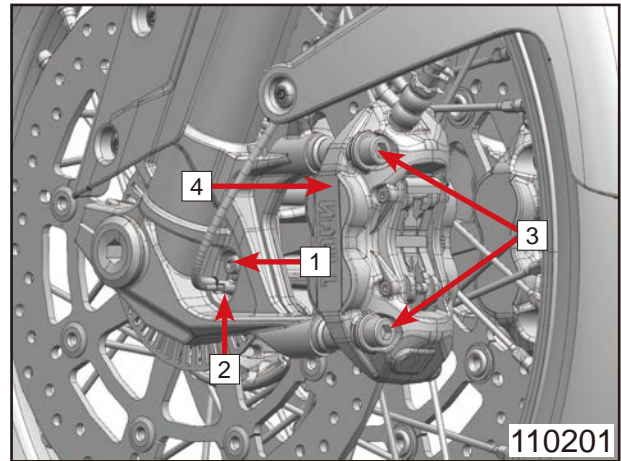

Remove inner hex bolt [5].

Remove RH front brake caliper [6].

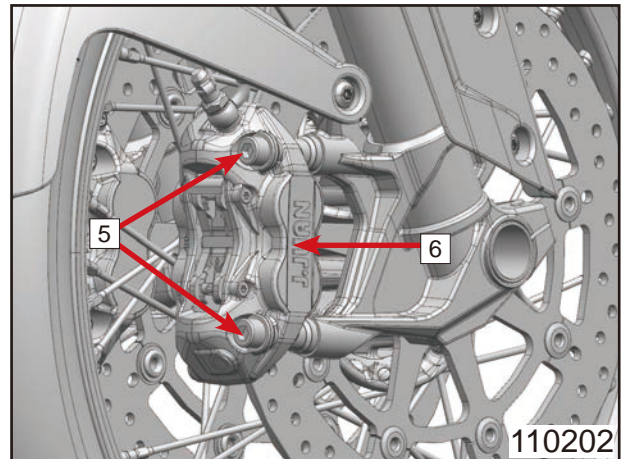

## 11.2 Front Wheel

Remove inner hex bolt [1].

Remove nut [2].

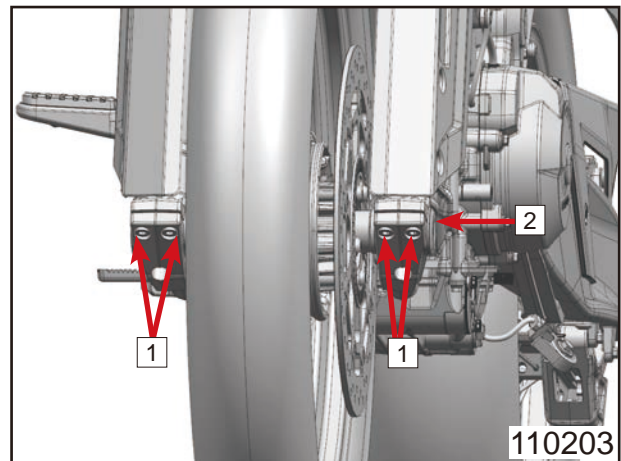

Pull out front wheel shaft [3].

Remove front wheel [4].

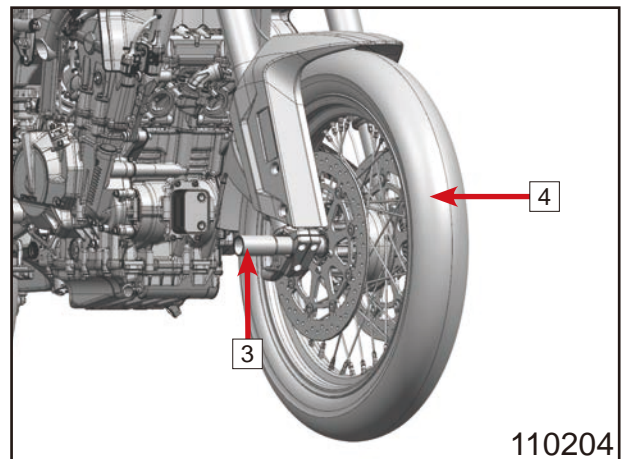

# 11 Wheels and Brake System

Keep front wheel spacer **5** and bushing **6** to prevent missing.

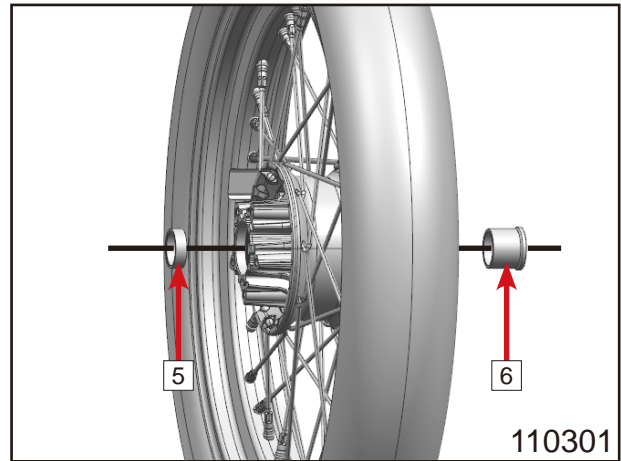

Remove inner hex bolts **7** on both sides.  
Remove front fender **8**.

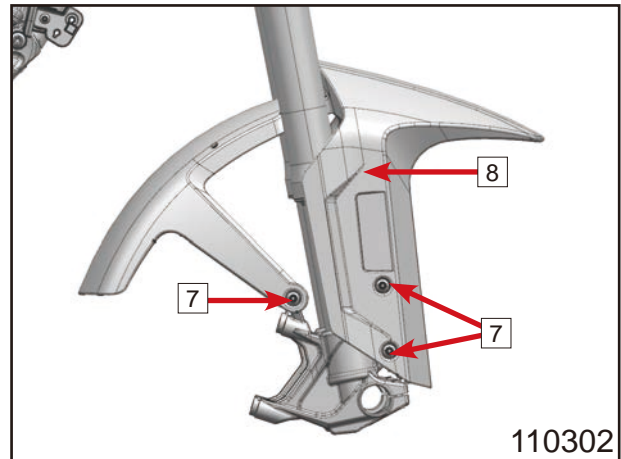

## 11.3 Rear Wheel Removal

Remove bolts **1**.  
Remove chain guide **2**.

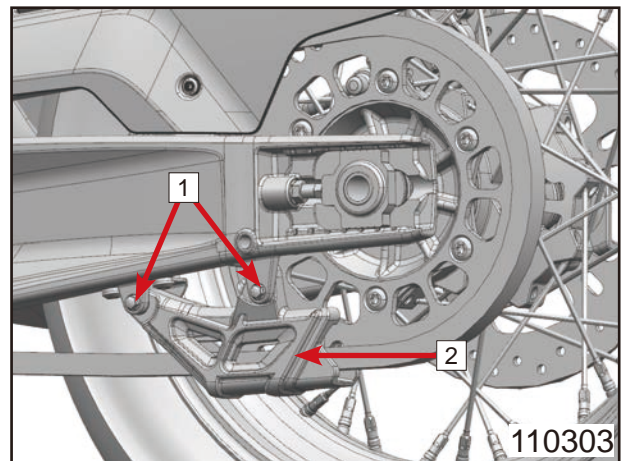

Remove nut **3**.  
Remove adjusting block **4**.

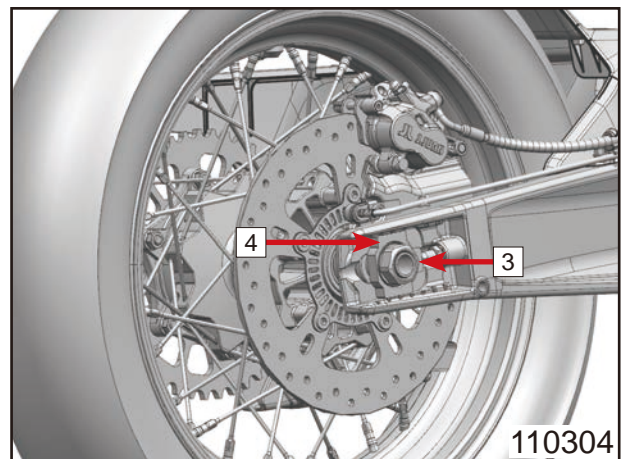

© CFMOTO Powersports, Inc. This manual is subject to all applicable copyright laws. Reproduction or duplication in any form, whole or in part, is strictly prohibited.

Pull out rear wheel shaft [5].  
 Push rear wheel [7] forward to release the chain.  
 Remove chain [6] from sprocket.  
 Remove rear wheel [7].

**⚠ CAUTION: Lean rear wheel slightly to right during removal, in case of sprocket seat falling down to cause injury.**

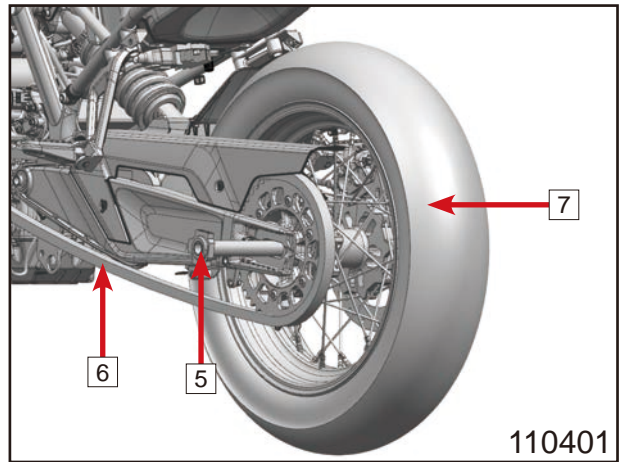

Keep wheel bushing [8] to prevent missing.

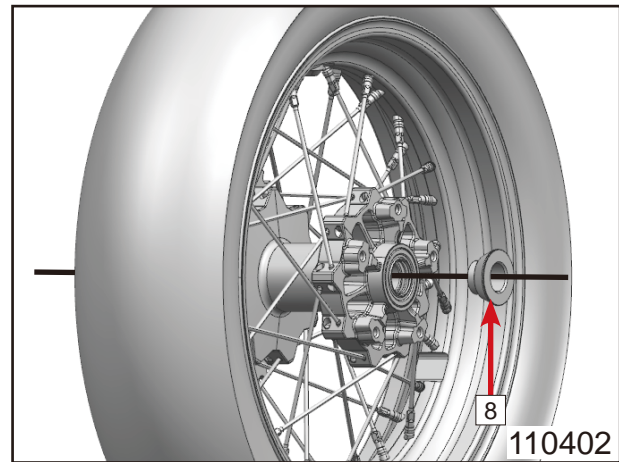

Remove inner hex bolts [9].  
 Remove rear fender [10].

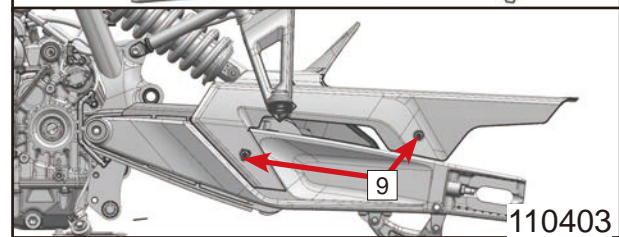
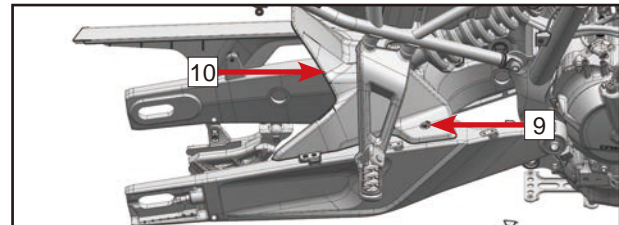

## 11.4 Rear Brake Caliper Removal

Remove rear brake caliper from limit block [2].  
 Remove rear brake caliper [1].

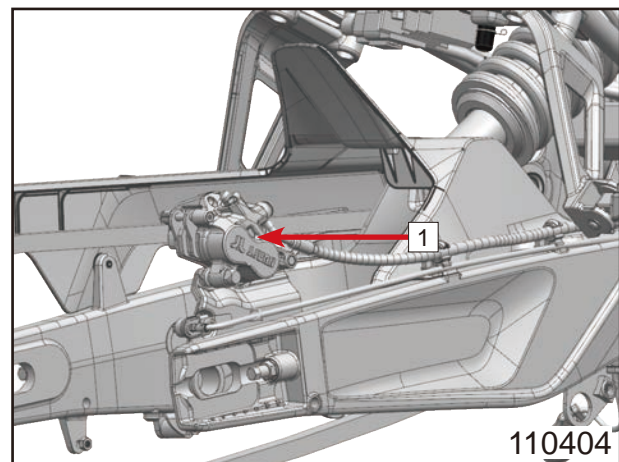

# 11 Wheels and Brake System

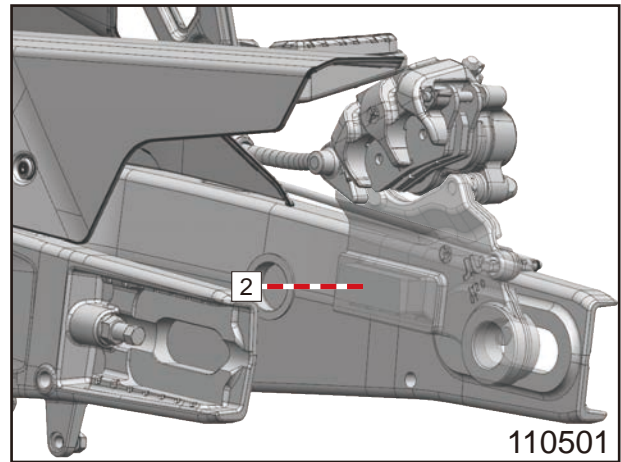

## 11.5 Brake Master Cylinder

Remove bolt [1].

Remove rear brake reservoir [2].

**⚠ CAUTION:** Never put brake fluid reservoir up side down, in case the air gets into the system, which leads to brake system failure.

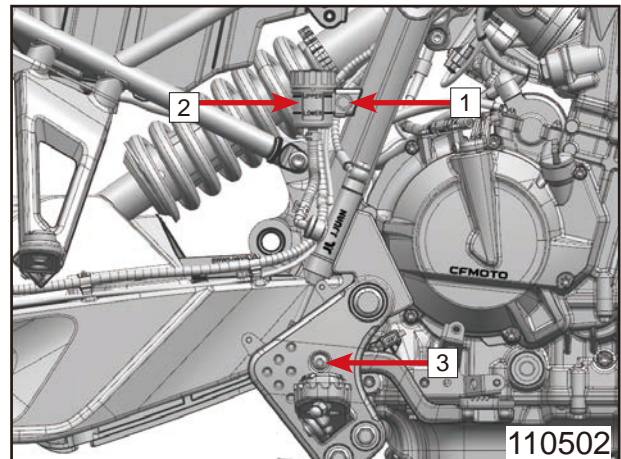

Remove inner hex bolt [3].

Remove inner hex bolts [4].

Remove spring [5] carefully.

Remove brake master cylinder [6].

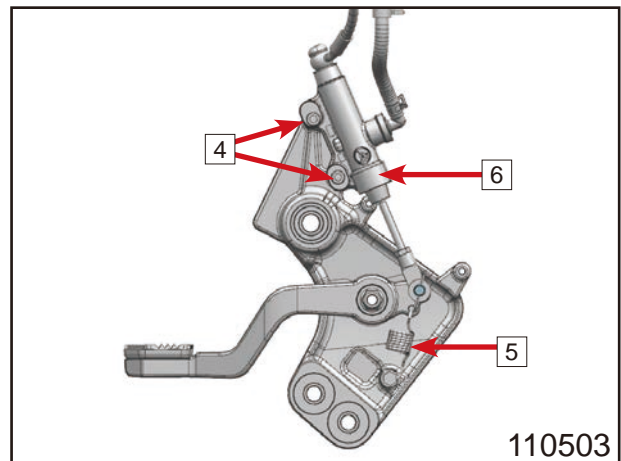

## 11.6 ABS Actuator

Remove bolt and washer [1].

Remove ABS actuator [2].

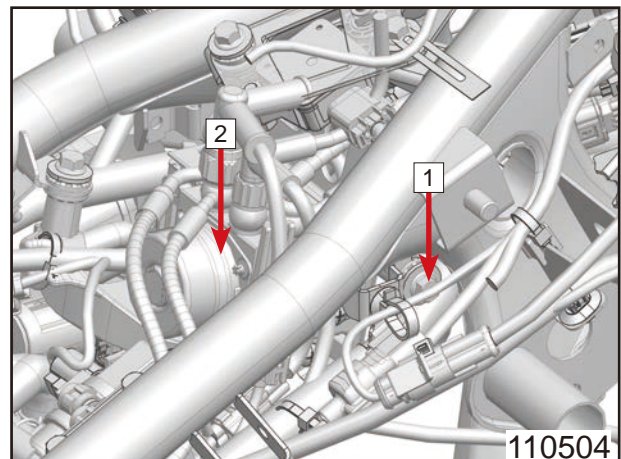

© CFMOTO Powersports, Inc. This manual is subject to all applicable copyright laws. Reproduction or duplication in any form, whole or in part, is strictly prohibited.

## 11.7 Hand Brake Master Cylinder Assy

### Removal

- Remove RH rear view mirror **1**.
- Remove inner hex bolt **2**.
- Remove RH hand guard **3**.

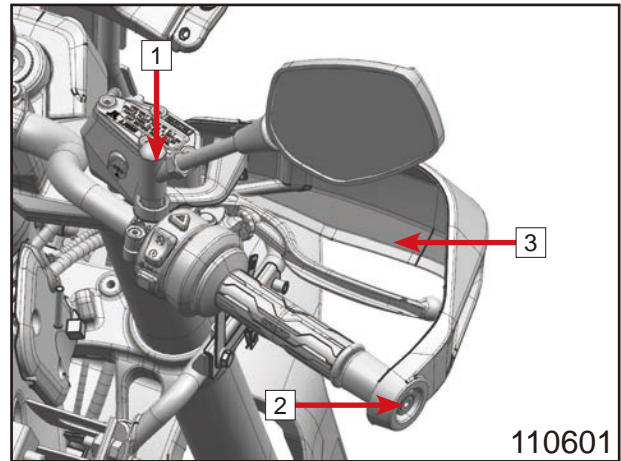

- Remove inner hex bolts **4**.
- Remove press cover **5**.
- Remove hand brake master cylinder assy **6**.

**⚠ CAUTION: Never put brake fluid reservoir up side down, in case the air gets into the system, which leads to brake system failure.**

Remove whole brake system.

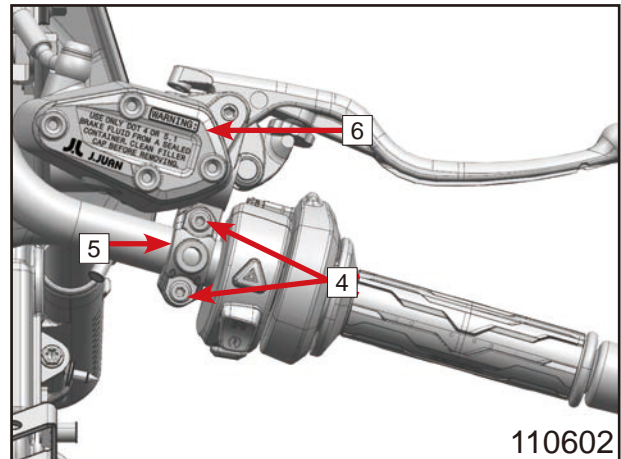

## 11.8 Wheel Inspection

### 11.8.1 Front Wheel

Inspect spokes **1** for twist, deformation, cracks or damage. Replace if any defect is found.

Inspect spoke elastic ring for deformation which leads to rim leakage and damage. Replace if any defect is found.

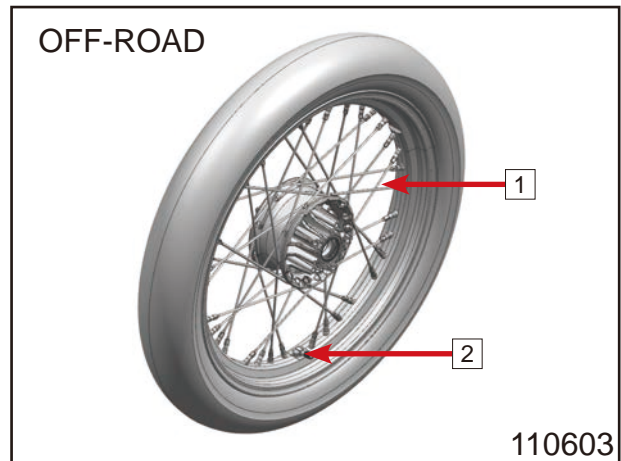

Inspect tire pressure sensor **2** inflating valve for damage or leaking. Replace with new tire pressure sensor if inflating valve is damaged or tire pressure abnormal.

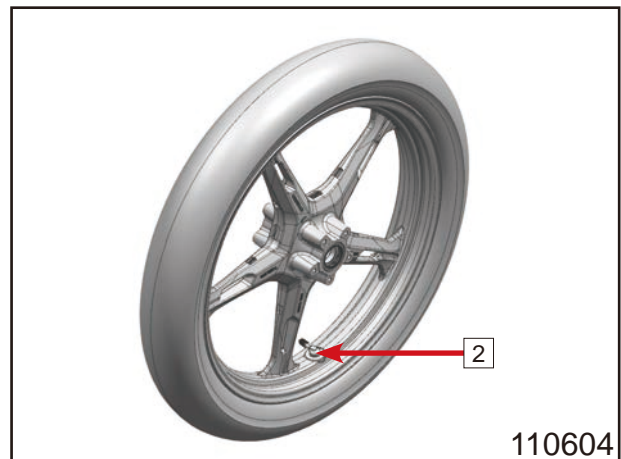

# 11 Wheels and Brake System

## 11.8.2 Rear Wheel

Remove sprocket **1** from rear wheel.

Inspect spokes **1** for twist, deformation, cracks or damage. Replace if any defect is found.

Inspect spoke elastic ring for deformation which leads to rim leakage and damage. Replace if any defect is found.

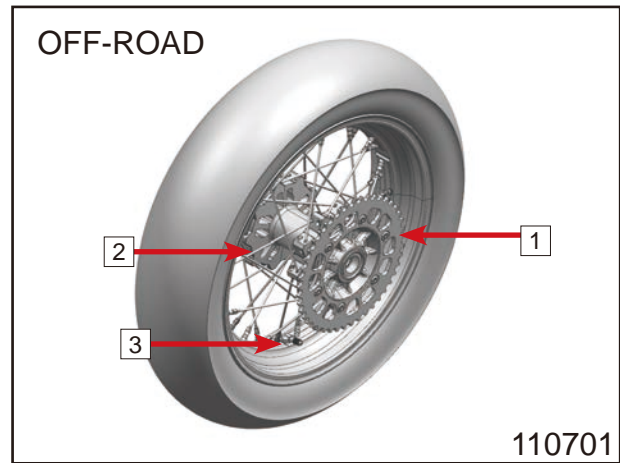

Inspect tire pressure sensor **2** inflating valve for damage or leaking. Replace with new tire pressure sensor if inflating valve is damaged or tire pressure abnormal.

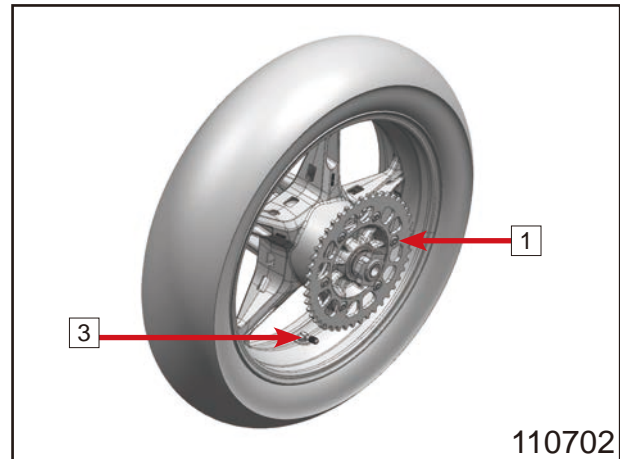

Inspect six damping rubbers **4** for aged or damage. Replace if any defect is found.

Inspect sprocket seat **1** and rear sprocket for wear or damage. Replace if any defect is found.

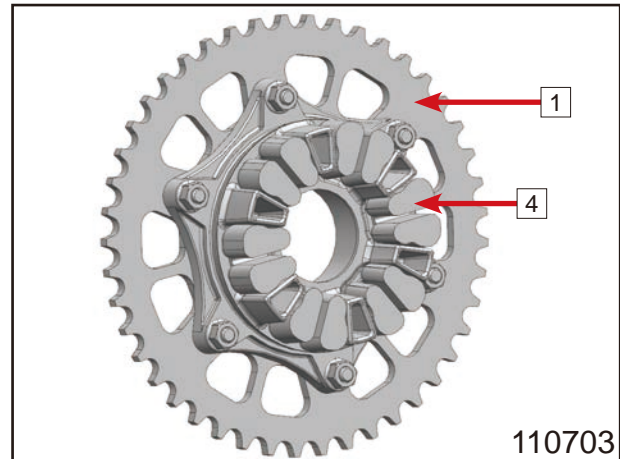

## Spoked Wheel

Check tire jump during tire replacement. If tire jump  $> 2.0$ , adjust spoke nut.

Inspect spokes for twist, deformation, cracks or damage. Replace if any defect is found.

Check spoke nut torque (value:  $4\text{N}\cdot\text{m}$ ~ $9\text{N}\cdot\text{m}$ ). If torque value is incorrect, set it to correct tighten torque and make spoke jump  $< 1.0$ .

## 11.8.3 Tire Pressure

Remove tire inflation valve cap.

Measure the tire pressure with air gauge **1** when it is cool.

Pressure	Signal	Pair
Front wheel	225kPa	240kPa
Rear wheel	250kPa	280kPa

Adjust the tire pressure according to the standard if necessary.

Install tire inflation valve cap.

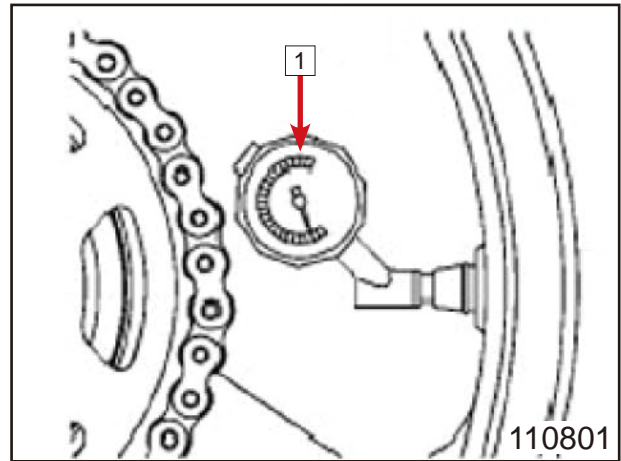

110801

## 11.8.4 Tire Appearance

Clean the embedded stone **2** or other inclusions **1** on tires.

Inspect the tire for cracks or damages by watching it. Replace if any defect is found.

If tire expands or has bulges on it, replace with a new tire.

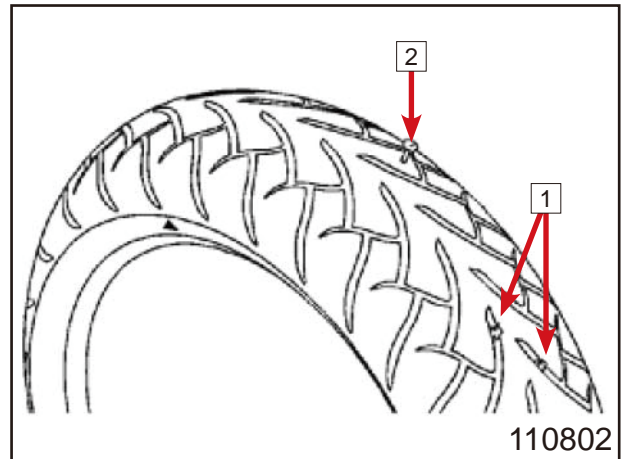

110802

Inspect tire for wear condition. The tire may be punctured or damaged if beyond service limit. Majority of the tire accidents happen due to exceeding service limit. Pay attention not to use the tire if the pattern is worn in case of injury.

When the tire thread wears to the block **1** height, replace a new tire.

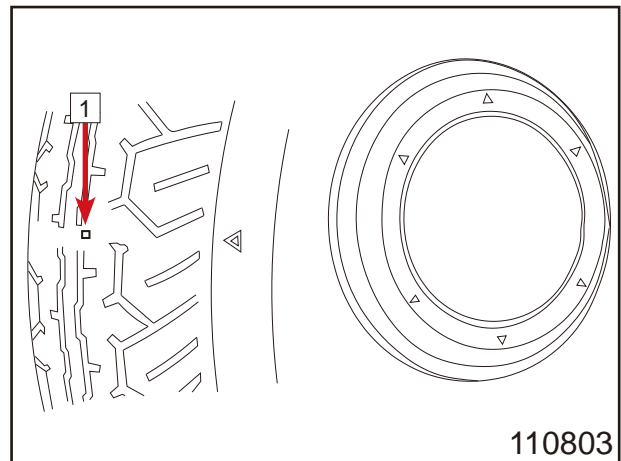

110803

# 11 Wheels and Brake System

## 11.8.5 Wheel Bearing

Lift the front wheel with jack.

Inspect the front wheel bearing for damage by pushing or pulling the wheel [A].

Rotate the front wheel [B] to inspect the for the smooth movement and noise.

Replace if any defect is found.

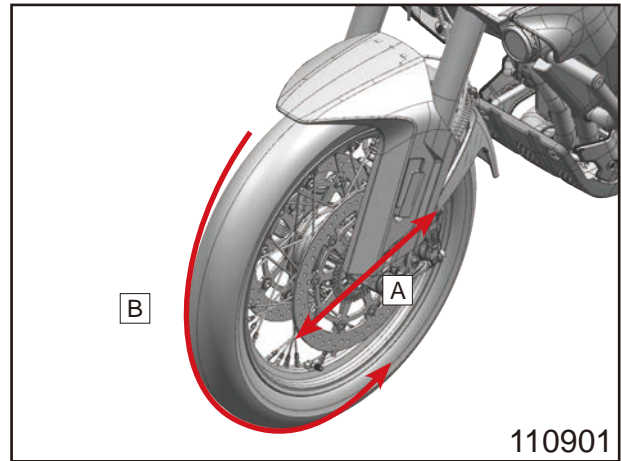

Lift the rear wheel with jack.

Inspect the rear wheel bearing for damage by pushing or pulling the wheel [A].

Rotate the rear wheel [B] to inspect the for the smooth movement and noise.

Replace if any defect is found.

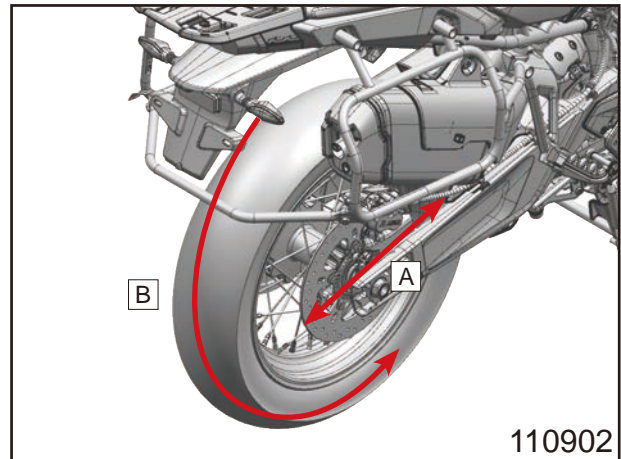

## 11.8.6 Rim

Inspect rim if sunk or damaged [1].

Inspect front wheel or rear wheel completely if any defect is found. Replace if necessary.

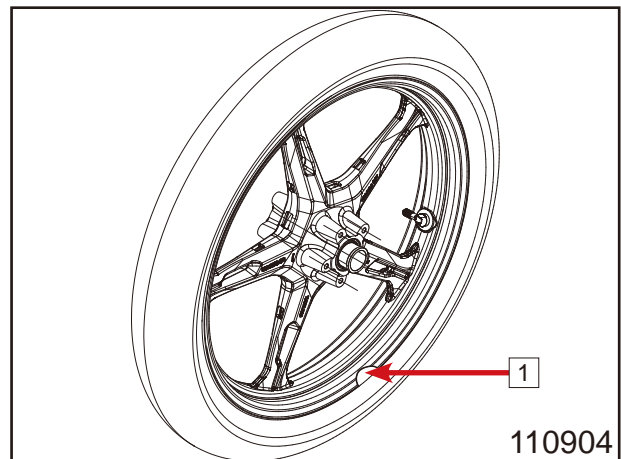
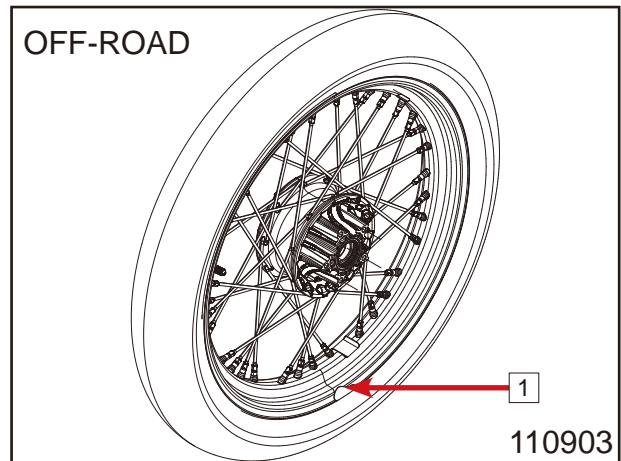

© CFMOTO Powersports, Inc. This manual is subject to all applicable copyright laws. Reproduction or duplication in any form, whole or in part, is strictly prohibited.

## 11.9 Brake System Inspection

### ⚠️WARNING:

Brake fluid can irritate the skin.

Keep the brake fluid out of reach of children.

Do not let brake fluid contact skin, eyes or clothing. Wear protective gears and goggles during operation.

If swallow brake fluid by accident, seek for medical attention immediately.

If you get brake fluid on skin, rinse contact area with clean water immediately.

If you get brake fluid in your eyes, immediately wash it off and seek for medical attention.

If you spill brake fluid on your clothing, change your clothing.

### 11.9.1 Hand Master Cylinder Inspection Front Brake Fluid Level Inspection

Straighten the vehicle to make the front brake fluid reservoir parallel the ground.

Watch the fluid level to check the fluid level.

Add or reduce the brake fluid until the level is between UPPER and LOWER line.

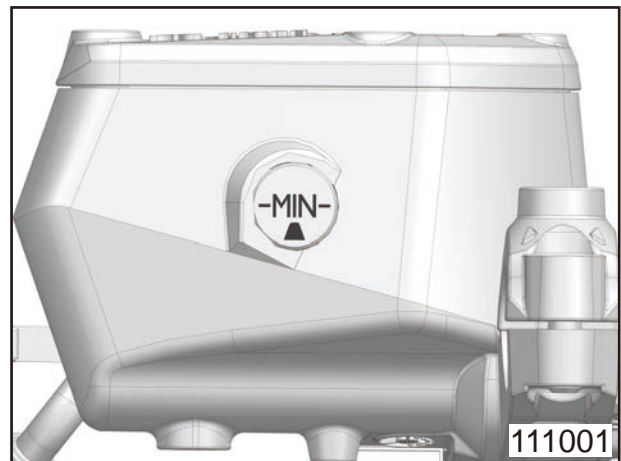

### Brake Fluid Replacement

Remove two screws [1].

Remove reservoir cap [2].

Remove reservoir gasket [3].

**NOTE: Reservoir gasket may be sunk due to negative pressure caused by brake fluid reducing. It doesn't affect normal use but needs to be restored during installation.**

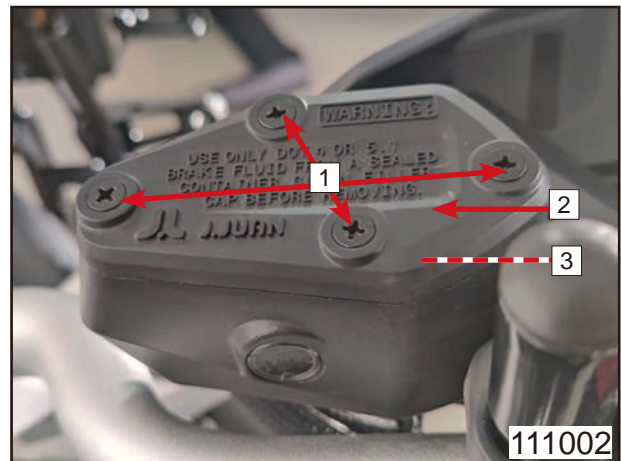

Open air-bleed bolt rubber cap [4].

Connect a clean hose with air-bleed bolt [5] with other side into a container.

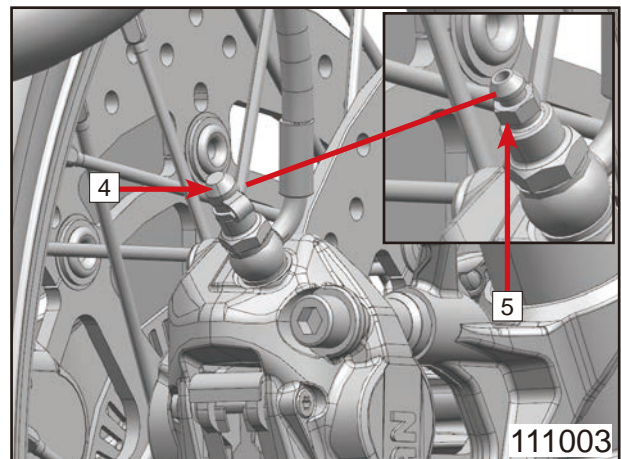

# 11 Wheels and Brake System

Repeatedly hold and loose [A] brake lever until it feels hard.  
Loose air-bleed bolt [5] a little bit.  
Tighten the bolt right after the brake fluid doesn't spray out or the lever feels soft.  
Add brake fluid.  
Repeat the above procedures until the new brake fluid sprays out.

**⚠ WARNING: Keep brake fluid level above LOWER, in case air gets into brake system, which results in brake system failure and injury.**

**⚠ WARNING: If there is air inside of brake system, replace brake fluid repeatedly until there is no air in drained brake fluid.**

## Brake Fluid Addition

Add brake fluid until the level is above LOWER and within view window.

Install reservoir gasket [3].  
Install reservoir cap [2].  
Install two screws [1].

## 11.9.2 Rear Master Cylinder Inspection Rear Brake Caliper

Straighten the vehicle to make the front brake fluid reservoir parallel the ground.  
Watch the fluid level to check the fluid level.  
Add or reduce the brake fluid until the level is between UPPER and LOWER line.

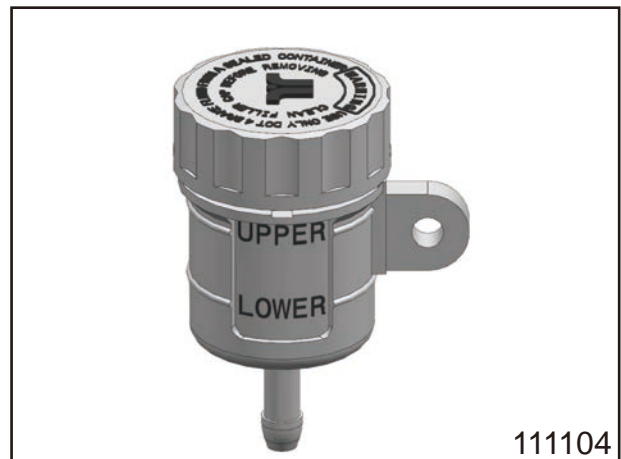
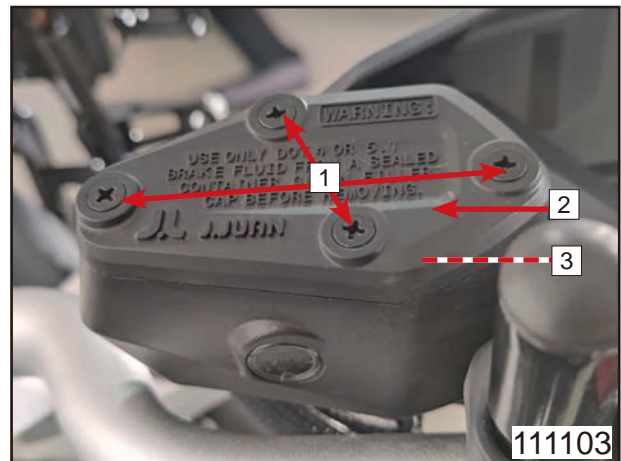
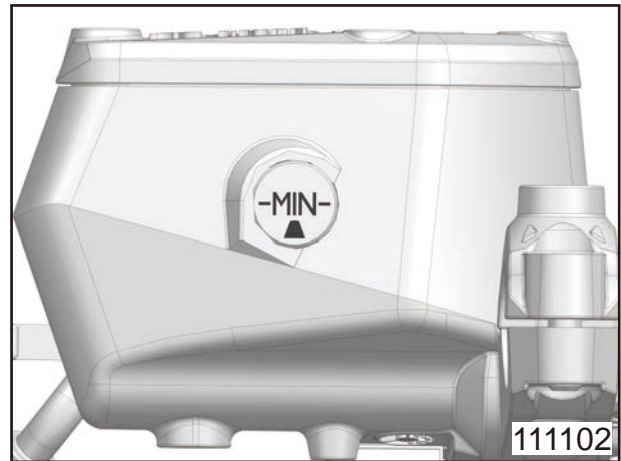
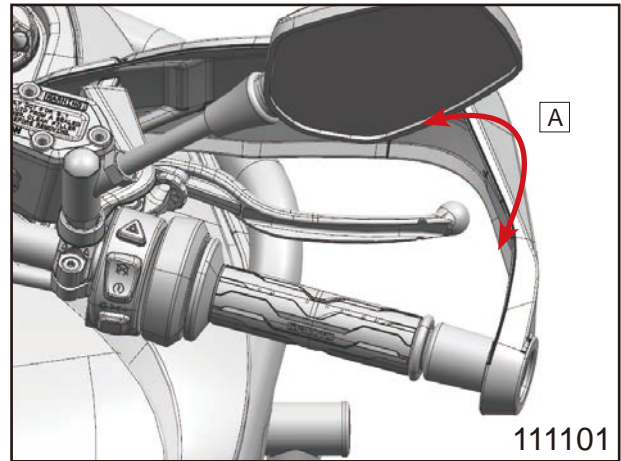

## Brake Fluid Replacement

Remove reservoir cap [1].

Remove reservoir gasket [2].

**NOTE:** The reservoir gasket may sag due to the reduction of negative pressure generated by brake fluid during daily use, which will not affect normal use. However, the reservoir gasket shall still be restored during installation.

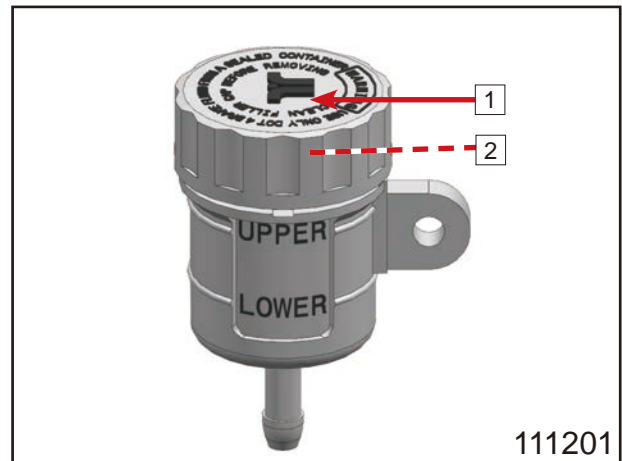

Open air-bleed bolt rubber cap [4].

Connect a clean hose with air-bleed bolt [5] with other side into a container.

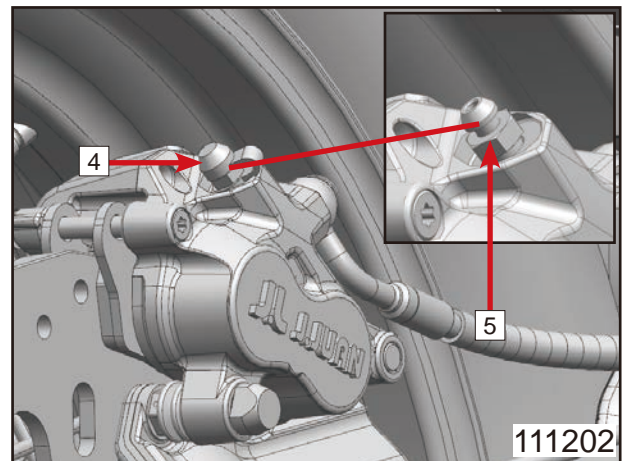

Repeatedly press and release [A] brake pedal until it feels hard.

Loose air-bleed bolt [6] a little bit.

Tighten the bolt right after the brake fluid doesn't spray out or the pedal feels soft.

Add brake fluid until the level is between UPPER and LOWER.

Repeat the above procedures until the new brake fluid sprays out.

**⚠ WARNING:** Keep brake fluid level above MIN, in case air gets into brake system, which results in brake system failure and injury.

**⚠ WARNING:** If there is air inside of brake system, replace brake fluid repeatedly until there is no air in drained brake fluid.

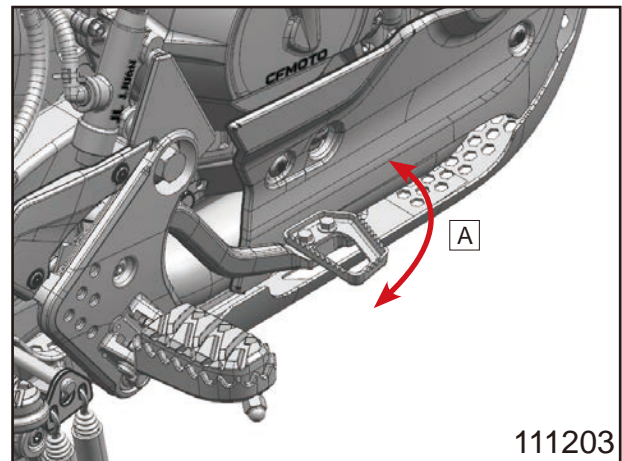

## Brake Fluid Addition

Add brake fluid until the level is between UPPER and LOWER.

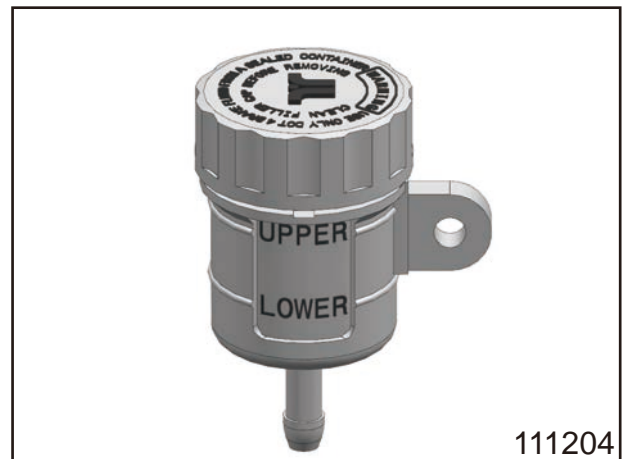

# 11 Wheels and Brake System

Install reservoir gasket [3].

Install reservoir cap [2].

## 11.9.3 Brake Hose Inspection

Inspect brake hose, connectors and pipes for damage, cracks or leaking.

With improper maintenance, the high pressure inside the brake hose can cause fluid leaking [A] or hose burst.

Inspect brake hose for bending or twist. Replace with new hoses and pipes if crack [B], bulge [C] or leaking detected.

Tighten all the brake hose connecting bolts and nuts.

Inspect brake hose route. Reset the hose route if not proper or correct.

## 11.9.4 Brake Calipers and Brake discs Inspection

### Front Brake Caliper

Remove brake caliper.

Inspect each brake pad thickness.

Brake pad thickness service limit: 2.5mm

Replace brake pads before it reaches to service limit. Replace brake pads in set.

Inspect brake pads for deep scratches or other damages. Replace if any defect is found.

**⚠ WARNING: Do not run the vehicle right after replacing new brake discs or pads. Do break-in on brake pads. Operate the brake lever several times until brake pad and brake caliper engage well.**

### Brake Disc

Inspect brake disc thickness.

Front brake disc thickness service limit: 3.5mm.

Rear brake disc thickness service limit: 4mm.

Replace brake discs before it reaches to service limit.

Inspect brake discs for deep scratches or other damages. Replace if any defect is found.

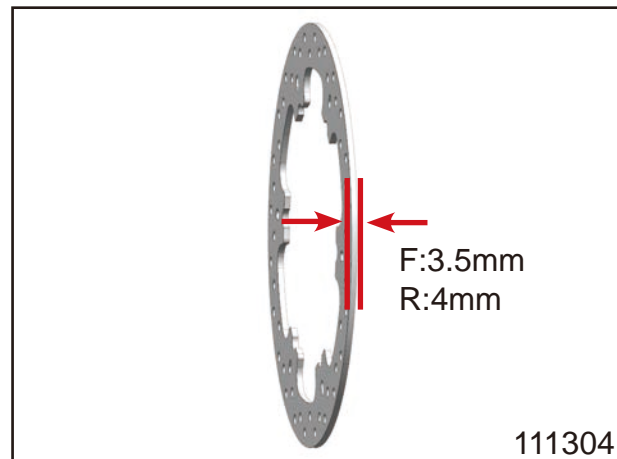
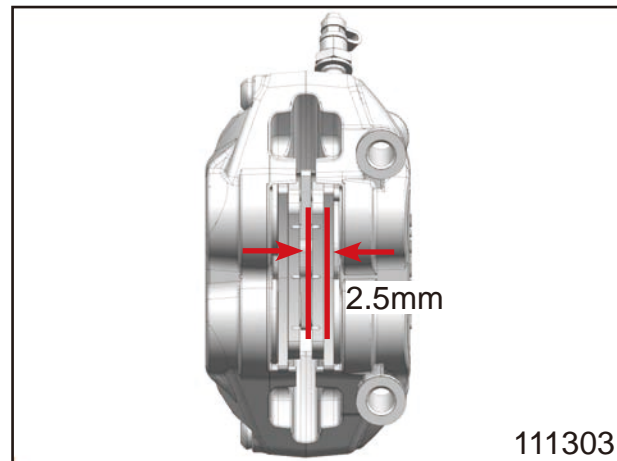
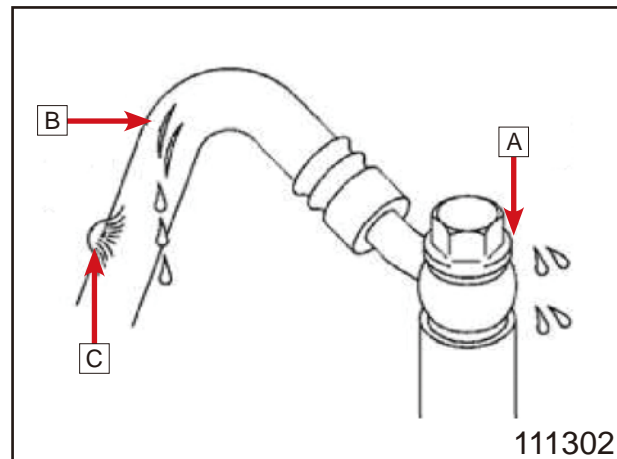
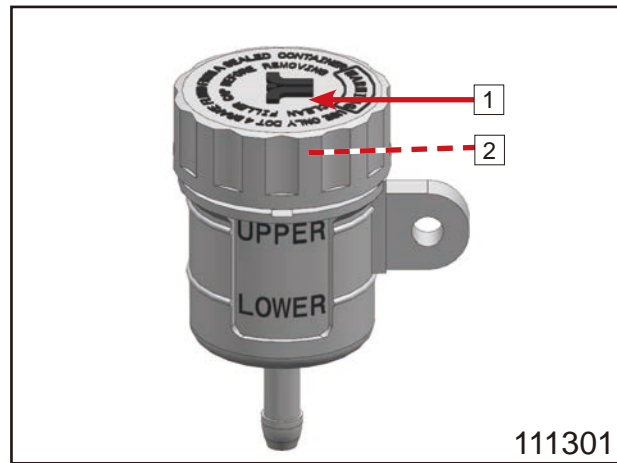

© CFMOTO Powersports, Inc. This manual is subject to all applicable copyright laws. Reproduction or duplication in any form, whole or in part, is strictly prohibited.

## 11.10 Free Play

### 11.10.1 Front Brake Lever Free Play

Inspect front brake lever free play **1**.  
Standard: 10mm~15mm

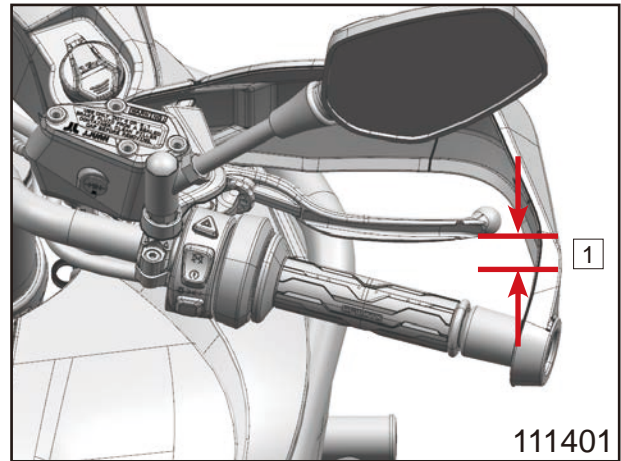

### 11.10.2 Rear Brake Pedal Free Play

Inspect rear brake lever free play **1**.  
Standard: 5mm~10mm

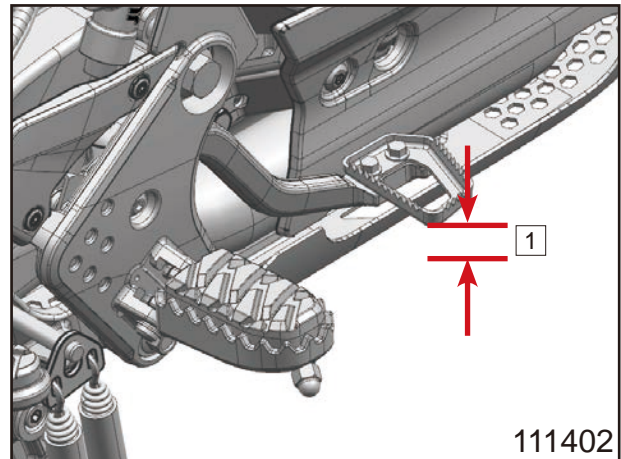

## 12 Shock Absorbers and Rear Fork

---

12.1 Handlebar .....	2
12.2 Front Shock Absorbers.....	2
12.3 Chain.....	2
12.4 Rear Fork.....	3
12.5 Chain Inspection.....	4
12.6 Front Shock Absorber.....	8
12.7 Rear Shock Absorber .....	8

## 12.1 Handlebar

Remove inner hex bolts and bushings [1] on both sides.

Remove two rear view mirrors [2].

Remove hand guards [3].

Insert bolts and bushings [1] in to prevent balancer missing.

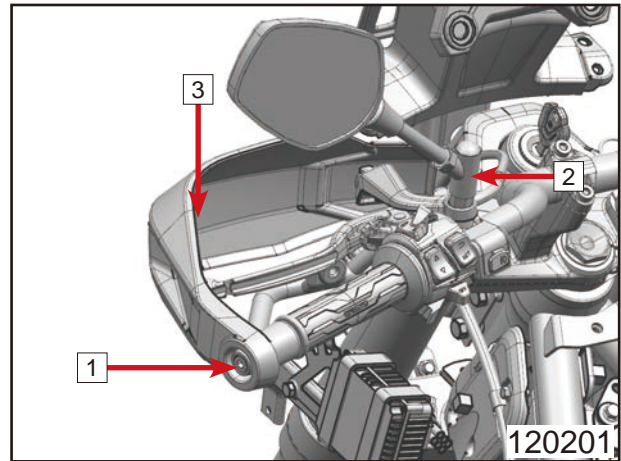

Remove inner hex bolts [4].

Remove handlebar press cover [5].

Place handlebar [6] carefully.

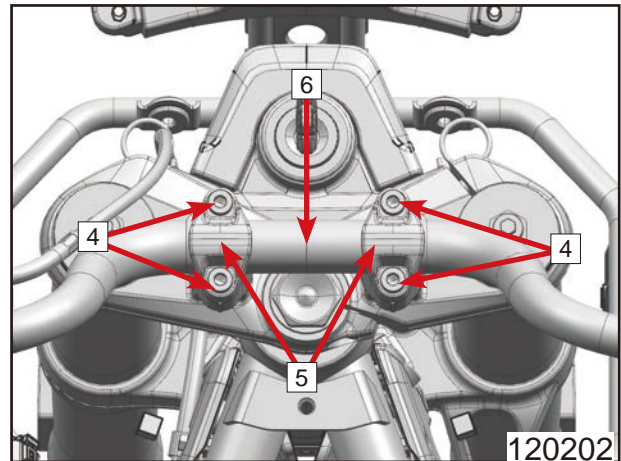

## 12.2 Front Shock Absorbers

Remove inner hex bolts [1] on both sides.

Remove LH&RH front shock absorbers [2].

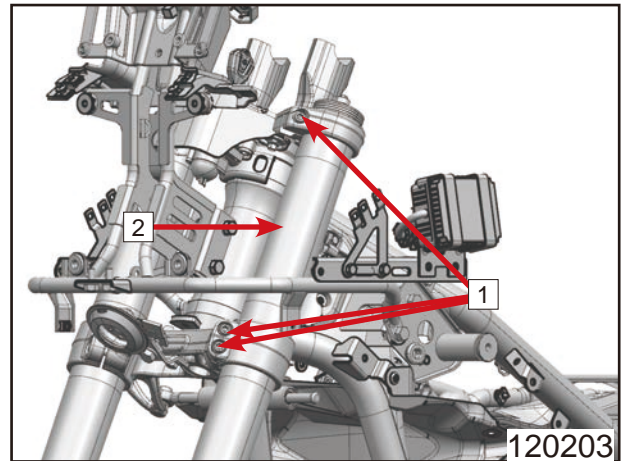

## 12.3 Chain

Remove bolts [1].

Remove bolt [2].

Remove inner hex bolt [3].

Remove LH footrest bracket.

Insert bolt [2] back.

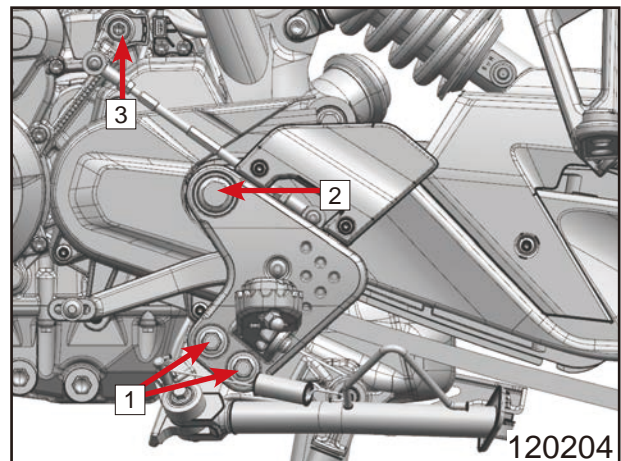

## 12 Shock Absorbers and Rear Fork

- Lift lock washer [2].
- Remove nut [1].
- Remove lock washer [2].

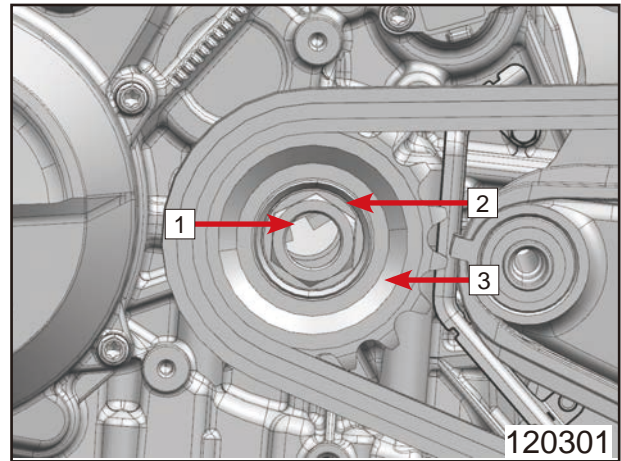

- Remove bolts [4].
- Remove chain guide [5].
- Remove chain.
- To prevent the chain from falling on the ground or coming into contact with other contaminants, such as chain smudges. The chain must be cleaned and lubricated with professional chain cleaning agent and chain oil during installation.

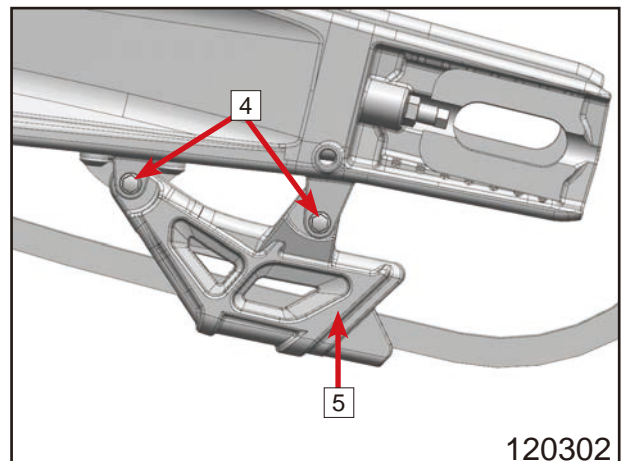

### 12.4 Rear Fork

- Remove inner hex bolt [1].
- Remove bolt and nut [2].
- Remove rear shock absorber [3].

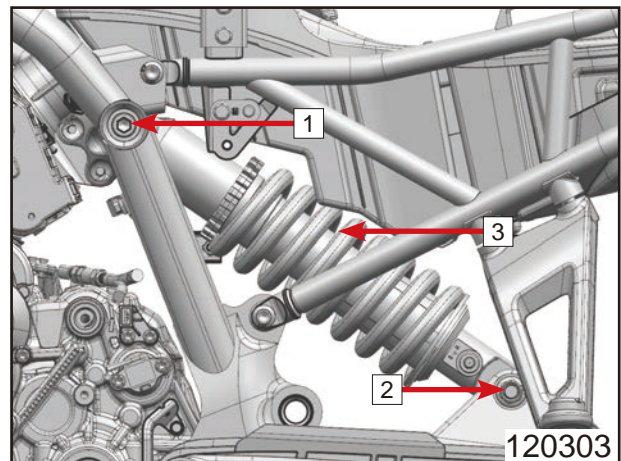

- Remove rear fork shaft [4].
- Remove rear fork [5].

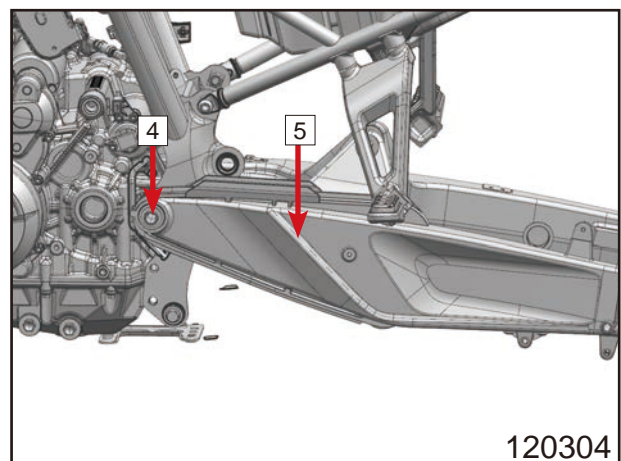

© CFMOTO Powersports, Inc. This manual is subject to all applicable copyright laws. Reproduction or duplication in any form, whole or in part, is strictly prohibited.

## 12.5 Chain Inspection

Press hard **1** to make two pin heads parallel.

Set the cutting and riveting pin **2** as picture shows.

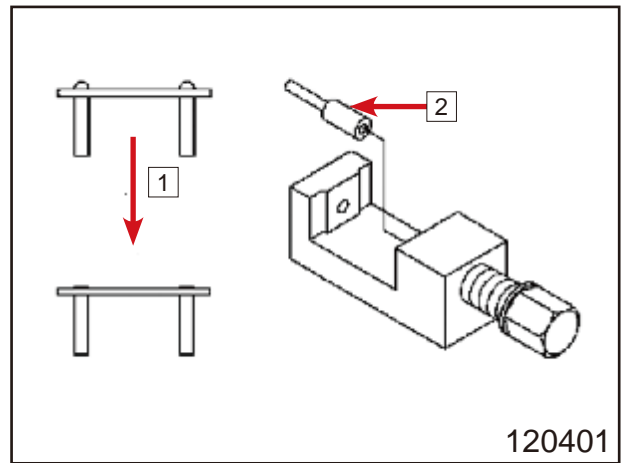

Tighten the bolt to narrow the pin seat until it touches chain pin.

Make sure the centers of cutting and riveting pin and chain pin are aligned.

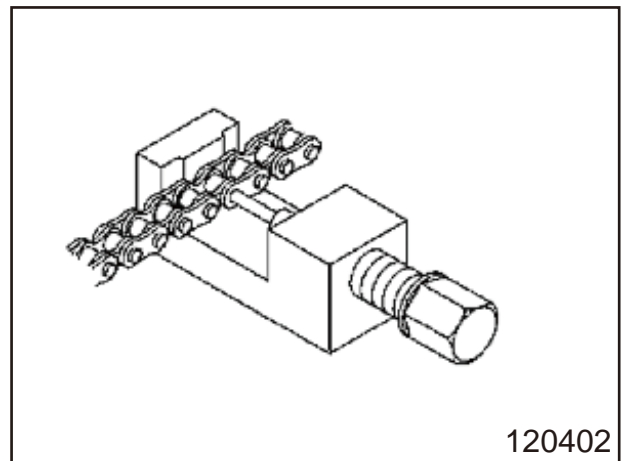

Rotate the pin seat with wrench **3** clockwise to remove the chain pin.

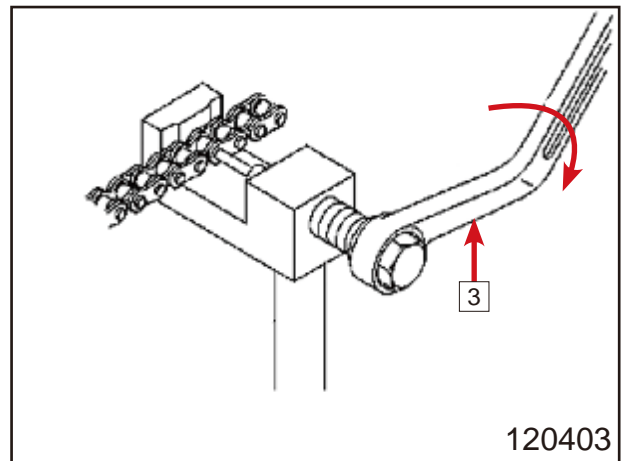

### Drive Chain Installation

Install new chain knots on chain to replace the old ones.

Remove the chain boards of new drive chain.

Apply grease on chain pin **2** and seal rings **1**.

Engage the chain and rear chain sprocket.

Insert chain pins into chain knots.

Install seal rings **1**.

Install chain boards and make the mark **3** face outside.

Fix the chain board with hand or plier.

Make sure the seal ring is installed correctly in case of the chain grease leaking.

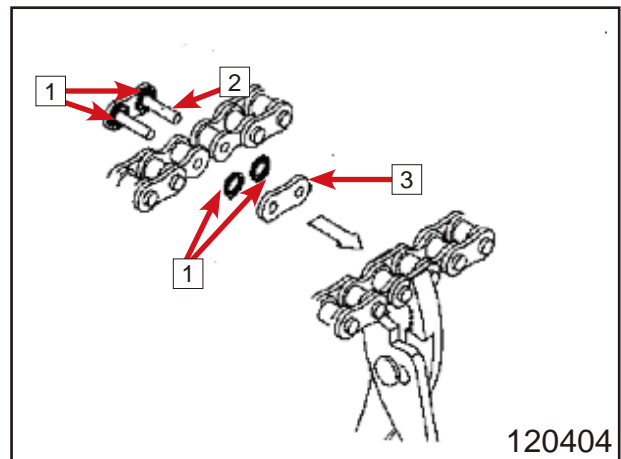

## 12 Shock Absorbers and Rear Fork

Set the holder **4** and **5**.

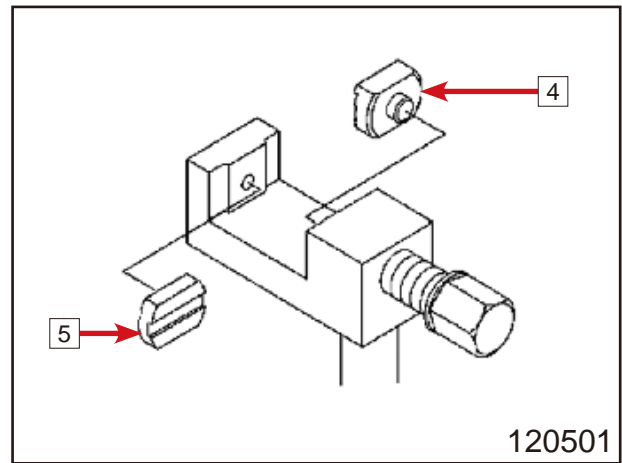

Align the holder and chain board.  
Rotate the pin seat until it touches the chain board.

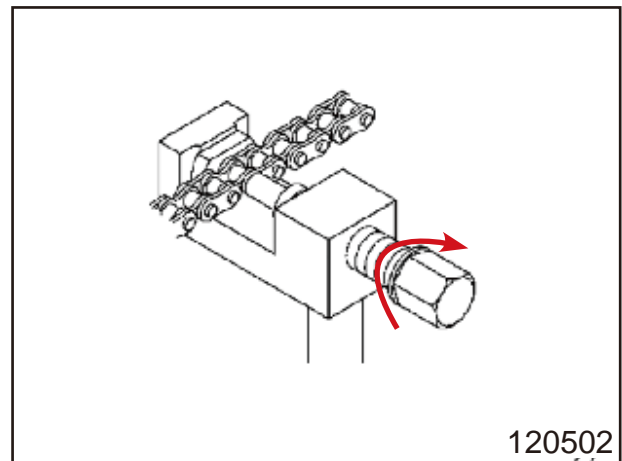

Rotate the pin seat with wrench clockwise until two pins get into the grooves of holder.  
Remove holder **4**.

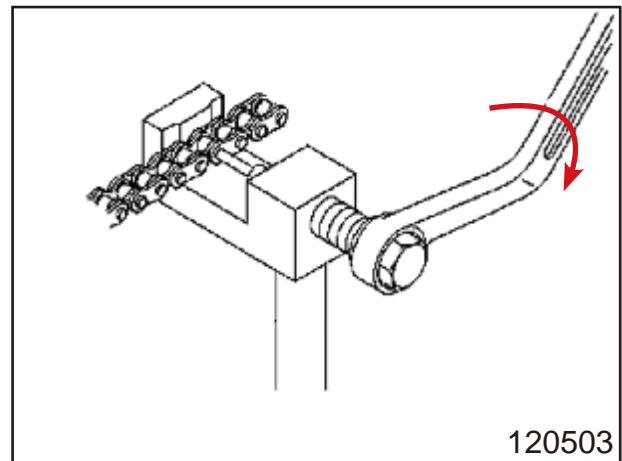

Set the holder **5** and cutting and riveting pin **6** as picture shows.

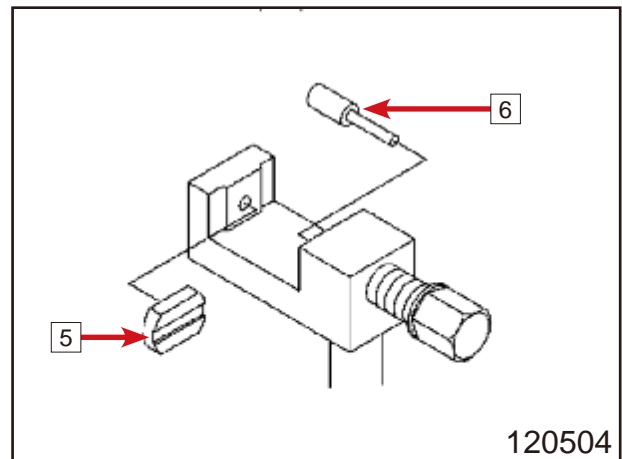

© CFMOTO Powersports, Inc. This manual is subject to all applicable copyright laws. Reproduction or duplication in any form, whole or in part, is strictly prohibited.

Rotate the pin seat until it touches chain pin.

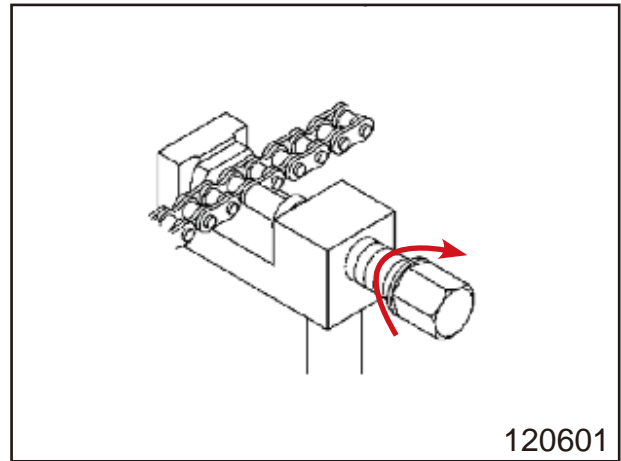

120601

Rotate the wrench clockwise until cutting and riveting pin head touches chain pin to rivet.

Other chain pins installation follows the same procedures.

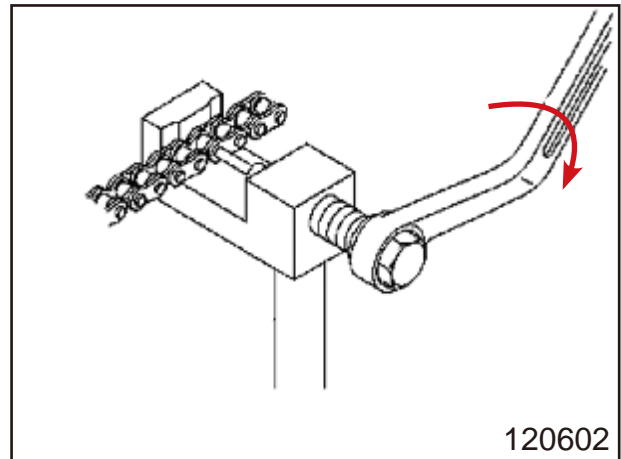

120602

### Inspection

After installation, inspect riveting knots for cracks. Measure chain pin outer diameter [1] and chain board width [2].

Chain pin outer diameter

Standard: 5.45mm~5.55mm

Chain board width

Standard: 17.25mm~17.45mm

Cut and re-rivet the chain knots if out of standard.

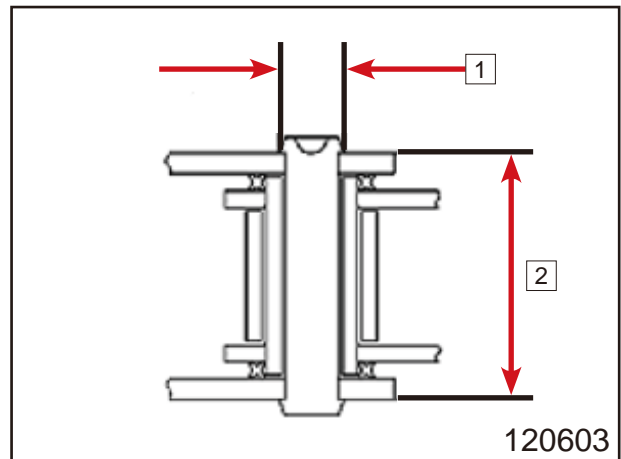

120603

### Chain Tension Inspection

Place the transmission into Neutral.

Park with the side stand on level ground.

In the natural state, the distance between the chain and the lowest point of the swing arm should not exceed 1.18 in (30 mm).

When pulling down the chain, the distance between the chain and the lowest point of swing arm should not exceed 1.96 in (50 mm).

If chain tension is out of specification, adjust it to the standard.

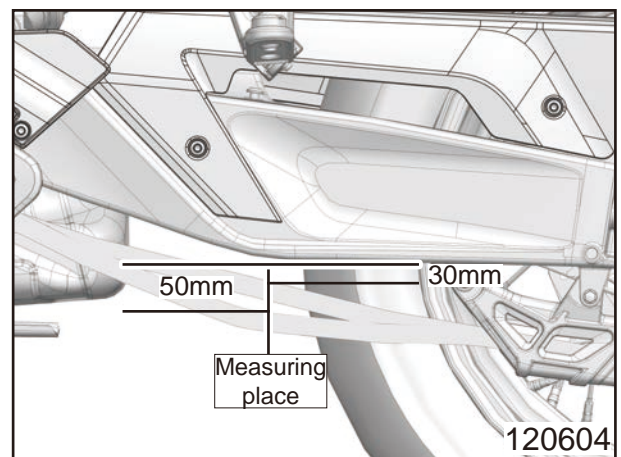

120604

# 12 Shock Absorbers and Rear Fork

**NOTE:** Rotate the rear wheel to different positions and repeat the measurement before adjusting chain tension.

## Chain Tension Adjustment

Loosen the rear wheel shaft nut **1**.  
Loosen the left and right locking nuts **3**.  
Rotate the left and right adjusting bolts **2** evenly to adjust chain tension, ensuring the alignment marks on the left and right chain tensioners **4** have the same reference mark position.  
Make sure the swing arm end firmly touches the adjusting bolts.  
Tighten the left and right locking nuts **3** and wheel shaft nut **1**.

**Wheel Shaft Nut Torque: 66.4 ft-lb (90 N•m)**

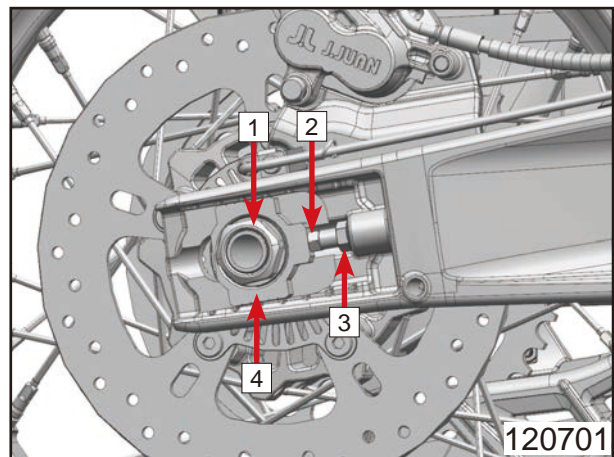

## Wear Inspection

Place the transmission into Neutral.  
Support the vehicle with side stand.  
Apply chain tensioning or hanging a 22 lb. (10 kg) object on the chain.  
Measure the length between 20 links for elongation. If the measured length exceeds the standard limit, replace the chain with a new one.  
Standard limit: 12.6 in (320.7 mm)

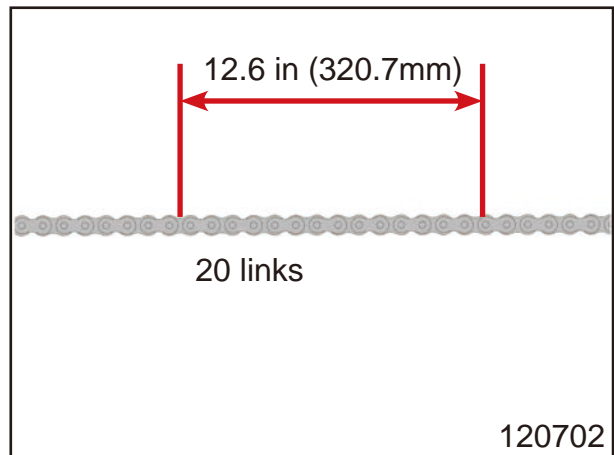

<b>⚠ DANGER</b>
For your safety, please use the standard chain. When chain is elongated, never cut the chain and mount back onto the vehicle. Have it replaced by an authorized CFMOTO dealer.

Inspect the rear sprocket and engine sprocket teeth for any kind of wear.  
If the engine sprocket or rear sprocket is worn, then replace the both sprockets as a set.

Inspect chain guard for wear. Inspect chain tightness if chain guard is worn. Replace chain and chain guard if necessary.

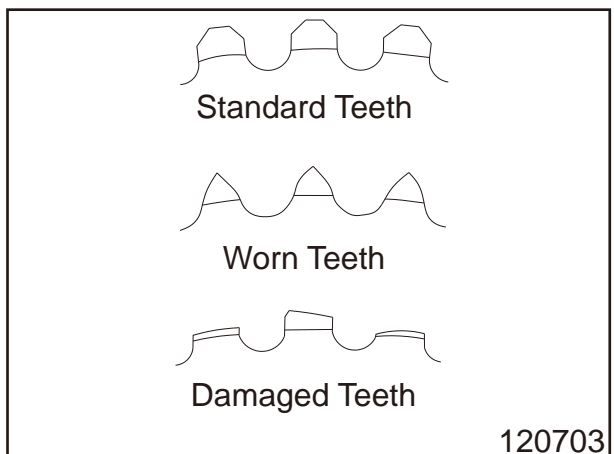

© CFMOTO Powersports, Inc. This manual is subject to all applicable copyright laws. Reproduction or duplication in any form, whole or in part, is strictly prohibited.

## 12.6 Front Shock Absorber

### Inspection

Inspect front shock absorber appearance for damage **2**, cracks **1** or other damage. Replace if any defect is found.

Clean dust and mud **3** on front shock absorber.

Press down handlebar several times to check compression/rebound function of front shock absorber.

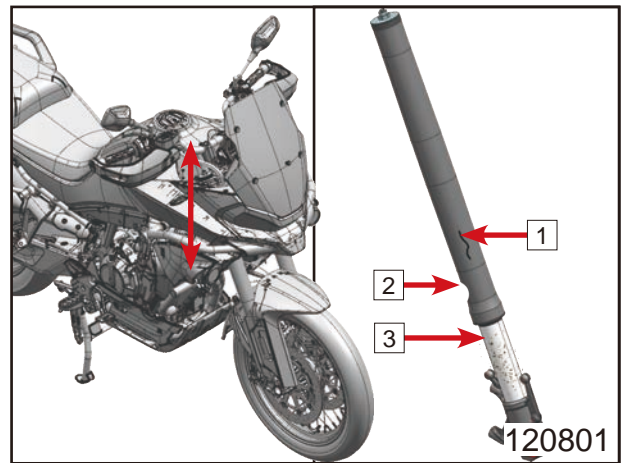

### Installation

Reverse the removal procedures for installation.

**⚠ CAUTION:** During installation, the upper surfaces **4** of both shock absorbers should be parallel.

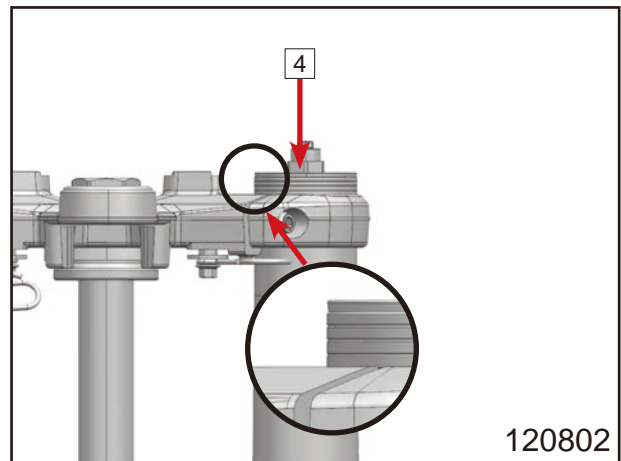

## 12.7 Rear Shock Absorber

Inspect rear shock absorber appearance for damage **2**, cracks **1** or other damage. Replace if any defect is found.

Clean dust and mud **3** on rear shock absorber.

Press down seat several times to check compression/rebound function of front shock absorber.

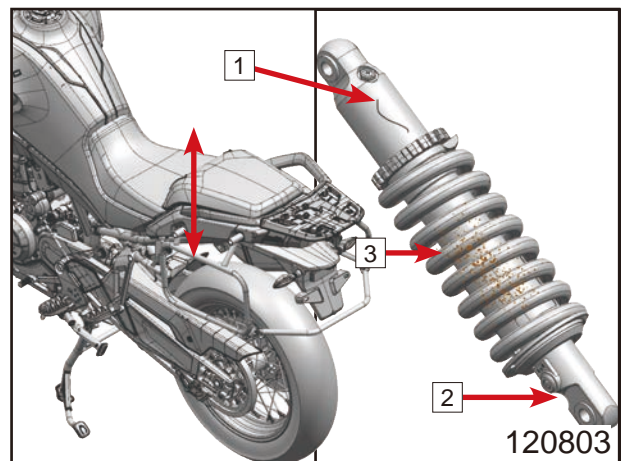

<b>13.1 Special Tools.....</b>	<b>13-5</b>
<b>13.2 Removing the Engine.....</b>	<b>13-7</b>
<b>13.3 Engine Disassembly.....</b>	<b>13-13</b>
13.3.1 Draining the Engine Oil .....	13-13
13.3.2 Removing the Oil Filter .....	13-13
13.3.3 Removing the Starter Motor .....	13-14
13.3.4 Removing the Valve Cover .....	13-14
13.3.5 Removing Shift Shaft Sensor.....	13-15
13.3.6 Removing the Gear Position Sensor .....	13-15
13.3.7 Removing the Spacer .....	13-16
13.3.8 Removing the Alternator Cover .....	13-16
13.3.9 Removing the Torque Limiter and Starter Intermediate Gear .....	13-17
13.3.10 Removing the Ignition Pulse Generator.....	13-17
13.3.11 Removing the Heat Exchanger .....	13-18
13.3.12 Removing the Thermostat.....	13-18
13.3.13 Removing the Water Pump Impeller.....	13-19
13.3.14 Removing the Clutch Cover .....	13-20
13.3.15 Removing the Clutch Discs.....	13-20
13.3.16 Removing the Clutch Basket .....	13-21
13.3.17 Removing Locking Lever .....	13-23
13.3.18 Removing the Shift Shaft .....	13-23
13.3.19 Removing the Spark Plugs.....	13-24
13.3.20 Removing the Camshafts .....	13-24
13.3.21 Removing the Cylinder Head .....	13-26
13.3.22 Removing the Timing Chain Rails .....	13-27
13.3.23 Removing the Rotor .....	13-27
13.3.24 Removing the Oil Pan .....	13-28
13.3.25 Removing the Oil Pump Unit.....	13-29
13.3.26 Removing the Engine Case Downwards.....	13-30
13.3.27 Removing the Transmission Shafts .....	13-31
13.3.28 Removing Oil Spray Tube.....	13-33

© CFMOTO Powersports, Inc. This manual is subject to all applicable copyright laws. Reproduction or duplication in any form, whole or in part, is strictly prohibited.

13.3.29 Removing the Piston .....	13-34
<b>13.4 Working on Individual Parts .....</b>	<b>13-35</b>
13.4.1 Checking the Radial Clearance of Crankshaft Bearings .....	13-35
13.4.2 Changing the Main Bearing Shells .....	13-36
13.4.3 Checking the Balancer Shaft .....	13-37
13.4.4 Working on the Upper Section of the Engine Case .....	13-37
13.4.5 Working on the Lower Section of the Engine Case .....	13-39
13.4.6 Selecting the Main Bearing Shells.....	13-40
13.4.7 Installing the Primary Gear Wheel.....	13-40
13.4.8 Radial Shaft Seal Ring of Water Pump, Changing .....	13-41
13.4.9 Checking the Radial Clearance of Lower Conrod Bearing .....	13-42
13.4.10 Changing the Conrod Bearing .....	13-43
13.4.11 Checking/Measuring the Cylinder .....	13-45
13.4.12 Checking/Measuring the Piston.....	13-46
13.4.13 Checking the Piston Ring End Gap.....	13-47
13.4.14 Determining the Piston/Cylinder Mounting Clearance .....	13-47
13.4.15 Removing the Oil Pumps.....	13-48
13.4.16 Checking the Oil Pumps for Wear .....	13-50
13.4.17 Checking the Oil Pressure Control Valve .....	13-51
13.4.18 Installing the Oil Pumps .....	13-51
13.4.19 Preparing Timing Chain Tensioner for Installation .....	13-53
13.4.20 Checking the Timing Assembly .....	13-55
13.4.21 Working on the Camshaft Bearing Bridge .....	13-56
13.4.22 Working on the Cylinder Head.....	13-58
13.4.23 Checking the Cylinder Head .....	13-63
13.4.24 Checking the Clutch .....	13-65
13.4.25 Removing the Shift Drum Locating Unit.....	13-66
13.4.26 Checking the Shift Mechanism .....	13-67
13.4.27 Preassembling the Shift Shaft .....	13-69
13.4.28 Installing the Shift Drum Locating Unit.....	13-69
13.4.29 Disassembling the Main Shaft .....	13-71
13.4.30 Disassembling the Countershaft .....	13-72

13.4.31	Checking the Transmission .....	13-73
13.4.32	Assembling the Main Shaft .....	13-75
13.4.33	Assembling the Countershaft .....	13-76
13.4.34	Checking the Electric Starter Drive .....	13-77
13.4.35	Checking the Freewheel .....	13-78
13.4.36	Working on the Alternator Cover .....	13-78
<b>13.5</b>	<b>Engine Assembly .....</b>	<b>13-80</b>
13.5.1	Installing the Piston .....	13-80
13.5.2	Installing the Oil Spray Tube .....	13-81
13.5.3	Installing the Transmission Shafts .....	13-82
13.5.4	Installing the Lower Engine Case .....	13-83
13.5.5	Installing the Oil Pump Unit .....	13-87
13.5.6	Installing the Oil Pan .....	13-87
13.5.7	Installing the Rotor .....	13-89
13.5.8	Installing the Timing Chain Rails .....	13-90
13.5.9	Installing the Cylinder Head .....	13-90
13.5.10	Installing the Camshafts .....	13-92
13.5.11	Checking the Valve Clearance .....	13-96
13.5.12	Adjusting the Valve Clearance and Cleaning the Oil Screen .....	13-97
13.5.13	Installing the Spark Plugs .....	13-98
13.5.14	Installing the Shift Shaft .....	13-98
13.5.15	Installing the Locking Lever .....	13-99
13.5.16	Installing the Clutch Basket .....	13-99
13.5.17	Installing the Clutch Discs .....	13-101
13.5.18	Installing the Clutch Cover .....	13-102
13.5.19	Mounting the Water Pump Cover .....	13-103
13.5.20	Installing the Thermostat .....	13-104
13.5.21	Installing the Heat .....	13-104
13.5.22	Installing the Crankshaft Speed Sensor .....	13-105
13.5.23	Installing the Torque Limiter and the Starter Intermediate Gear .....	13-105
13.5.24	Installing the Alternator Cover .....	13-106
13.5.25	Installing the Spacer .....	13-107

13.5.26 Installing the Gear Position Sensor .....	13-107
13.5.27 Installing the Shift Shaft Sensor .....	13-107
13.5.28 Installing the Valve Cover.....	13-108
13.5.29 Installing the Starter Motor .....	13-110
13.5.30 Installing the Oil Filter .....	13-110
13.5.31 Installing the Oil Drain Plug .....	13-110

© CFMOTO Powersports, Inc. This manual is subject to all applicable copyright laws. Reproduction or duplication in any form, whole or in part, is strictly prohibited.

## 13.1 Special Tools

### Magneto Rotor Removal Tool

CKM601700-00300



### Balancer Shaft Alignment Testing Tool

CKM601700-00038



### Timing Camshaft Testing Tool

CKM601700-00036



### Insertion for Piston Ring Lock

CKM601700-00013



© CFMOTO Powersports, Inc. This manual is subject to all applicable copyright laws. Reproduction or duplication in any form, whole or in part, is strictly prohibited.

## Crankshaft Locking Screw

CKM601700-00033



## Release Device for Timing Chain Tensioner

CKM601700-02311



## Clutch Stop Tool

CKM601700-00515

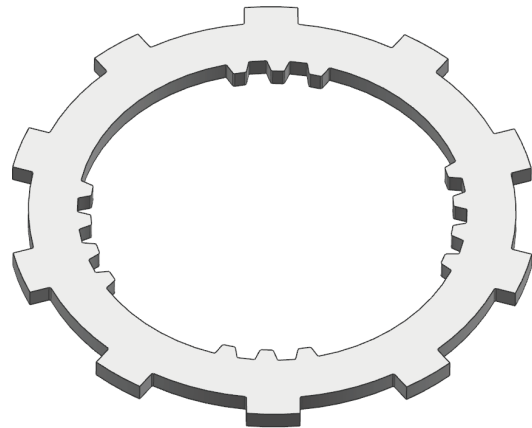

## 13.2 Removing the Engine

### Preparatory Work

Switch off the ignition by turning the ignition key to the position  $\otimes$ .

Remove the seat.

Disconnect the negative cable of the 12-V battery.

Remove main silencer.

Raise motorcycle with rear lifting gear.

Remove the left side cover.

Remove the battery cover.

Remove left fuel tank cover.

Remove the right side cover.

Remove right fuel tank spoiler.

Remove engine guard.

Remove the fuel tank.

Remove the exhaust system.

Drain the coolant.

### Main Work

Remove screws **1**.

Hang the activated charcoal filter to the side.

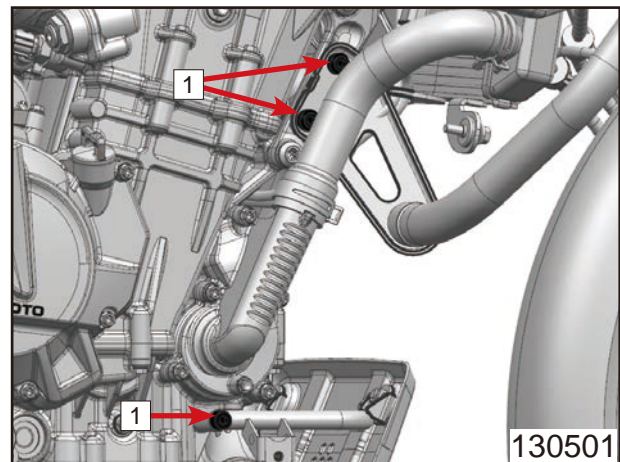

Loosen hose clips **2**.

Pull off the radiator hoses.

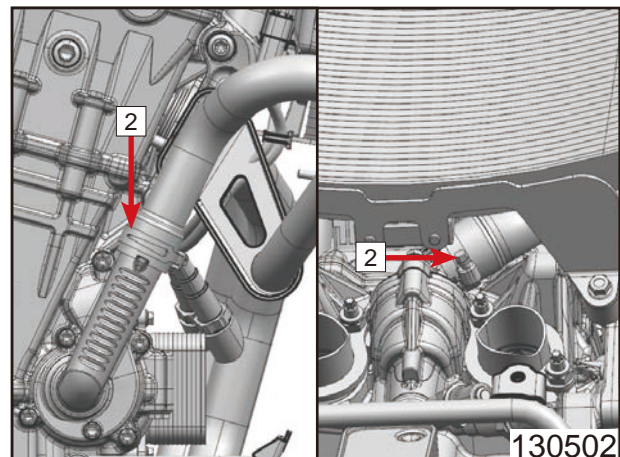

# CFMOTO

Remove screws **3**.  
Swing the radiator forward.

**NOTE**

Pay attention to the cooling fins.

Remove the cable ties.  
Disconnect plug-in connector.

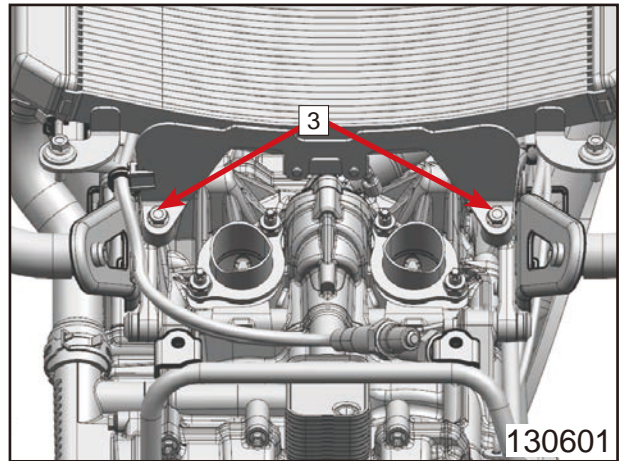

Remove hose clamp **4** and pull off the vent hose.

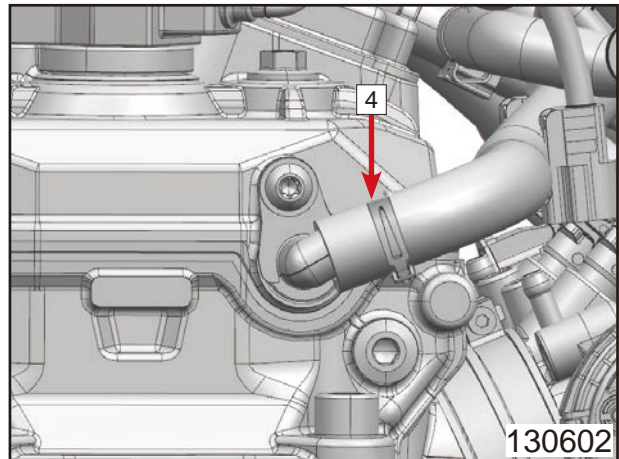

Swivel clutch release lever **5** counterclockwise and detach the inner clutch cable.

Remove screws **6**.

Hang the inner clutch cable with bracket to the side.

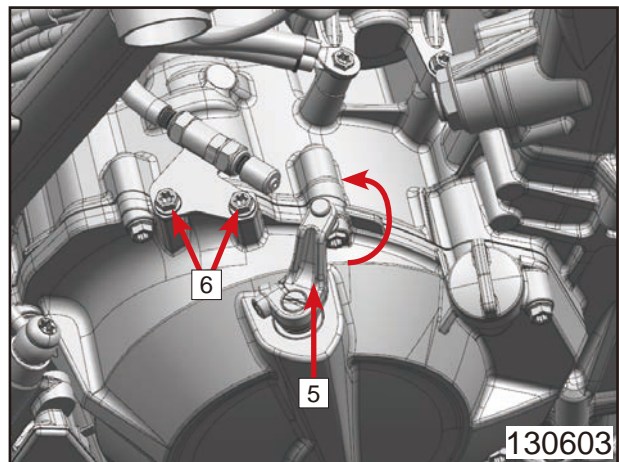

Push back protection cap **7** and remove the nut.

Hang the positive cable to the side.

Remove screws **8**.

Hang the ground wire to the side.

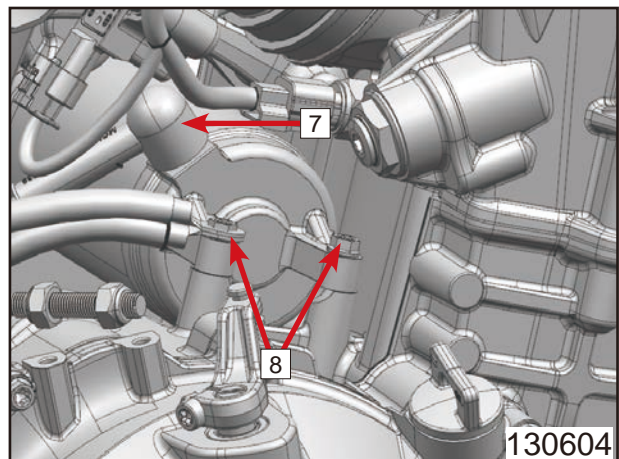

## 13 Engine

Disconnect connector **9** from the coolant temperature sensor.  
Unplug connector **10** from the oil pressure sensor.

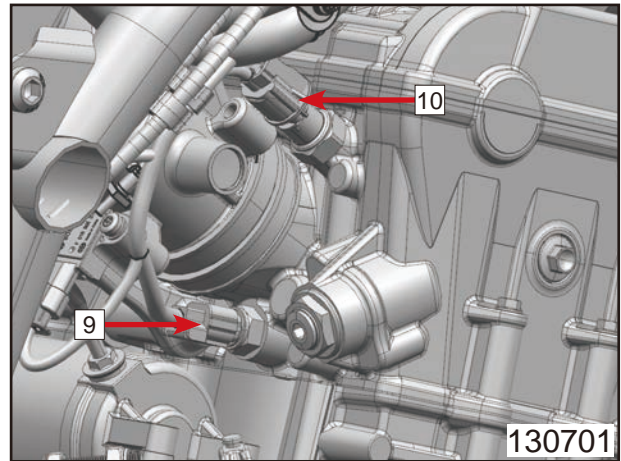

Bend up the lock washer.  
Have an assistant operate the rear brake.  
Loosen nut **11**.

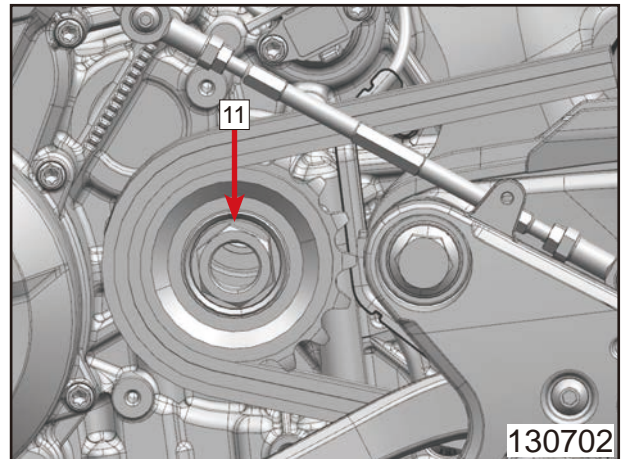

Remove nut **12**.  
Remove the chain adjuster.  
Push the rear wheel into the foremost position.

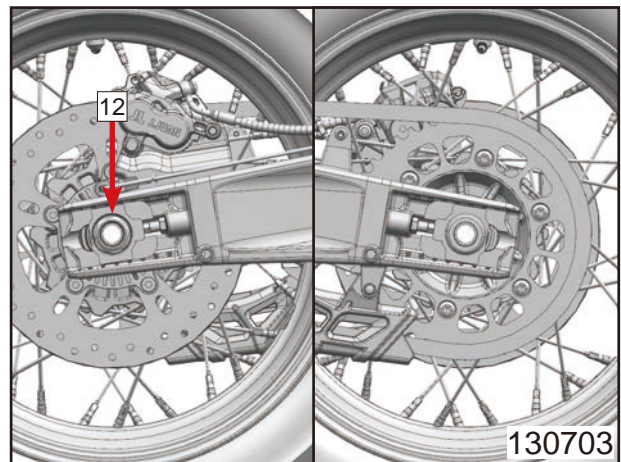

Remove nut **13** with the lock washer.  
Take off the engine sprocket.

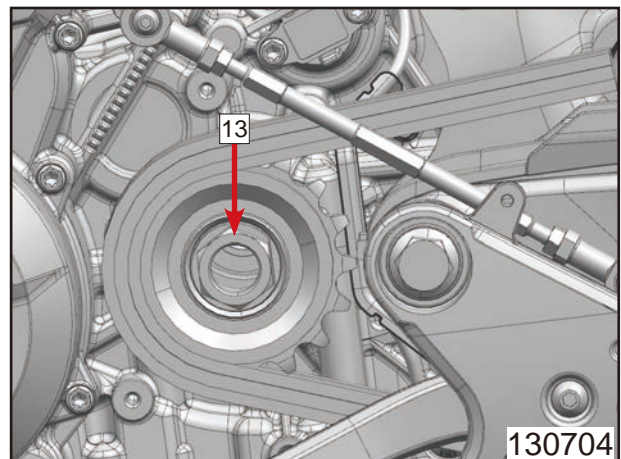

© CFMOTO Powersports, Inc. This manual is subject to all applicable copyright laws. Reproduction or duplication in any form, whole or in part, is strictly prohibited.

# CFMOTO

Loosen hose clips **14**.

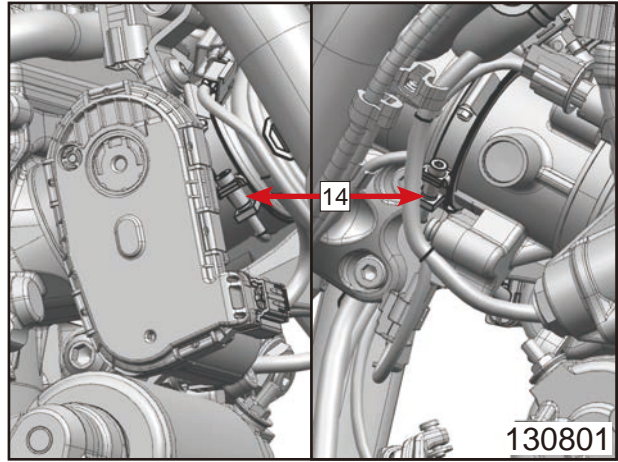

Loosen screws **15**.  
Remove screws **16**.  
Swivel the subframe downward.

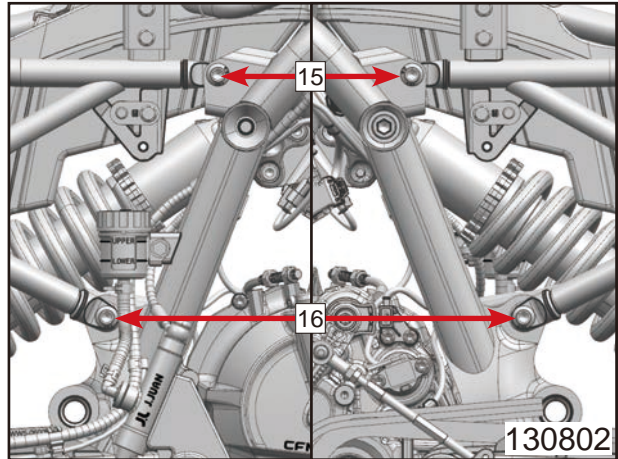

Remove hose clips **17**.

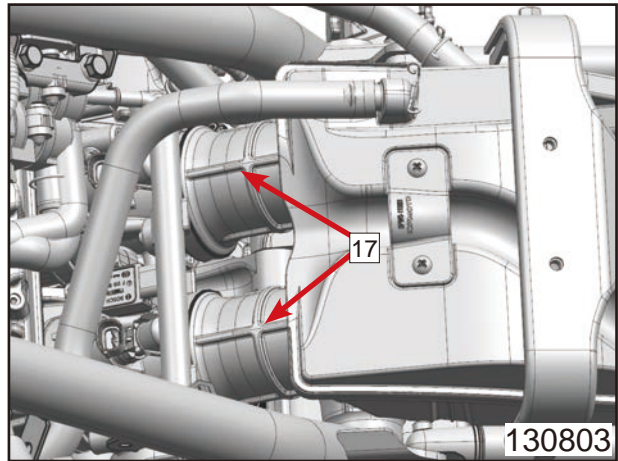

Pull off hose **18**.

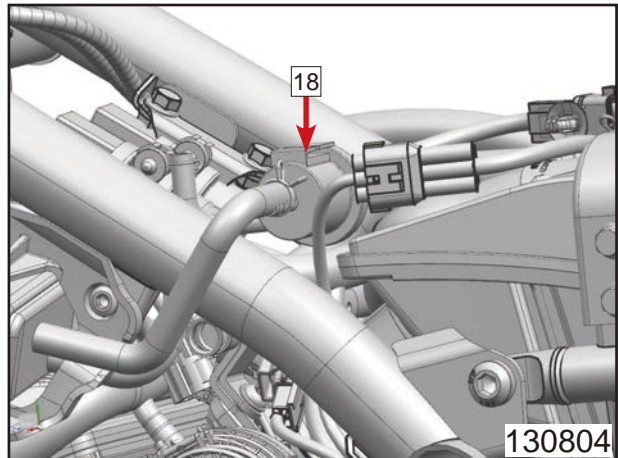

## 13 Engine

Loosen hose clips **19**.  
Pull off the throttle valve body toward the rear and remove to the side.

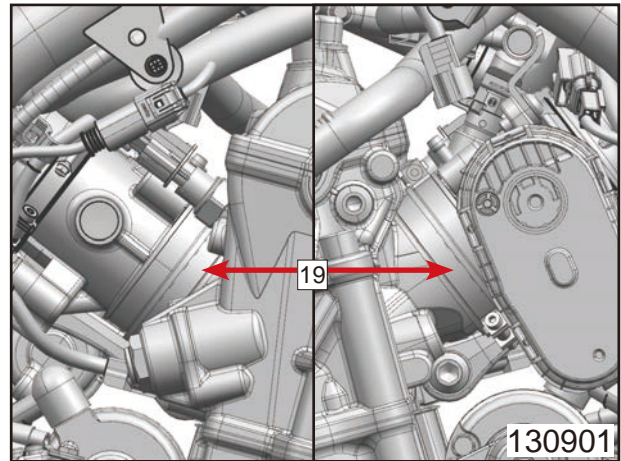

Use support to prop up the bottom of the engine.  
Remove protection cap.  
Loosen screw **20**.

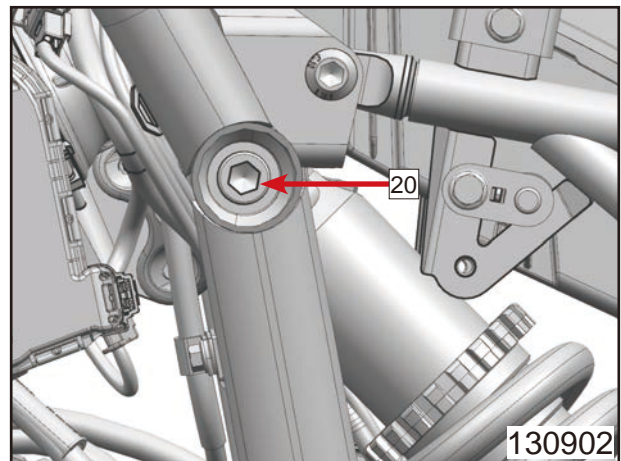

Remove screw **21**.  
Remove the footrest bracket.

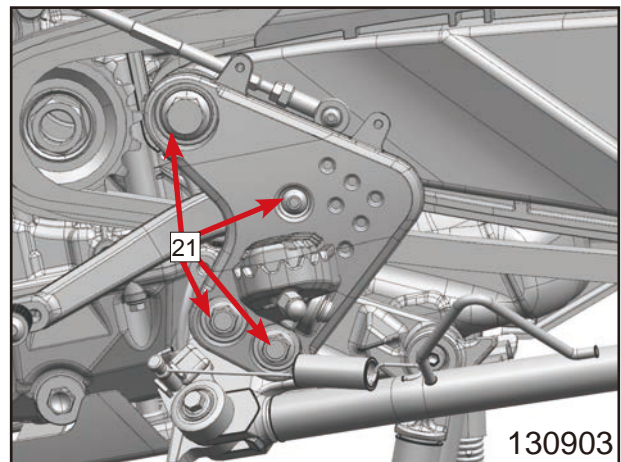

Remove screw **22**.  
Pull out swingarm pivot **23** far enough so that the engine is released but the link fork remains secured.

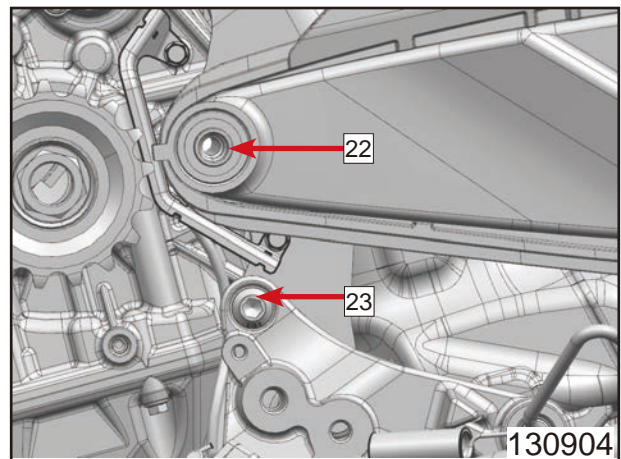

# CFMOTO

Remove screw 24.  
Remove screws 25.  
Take off the engine bearer.

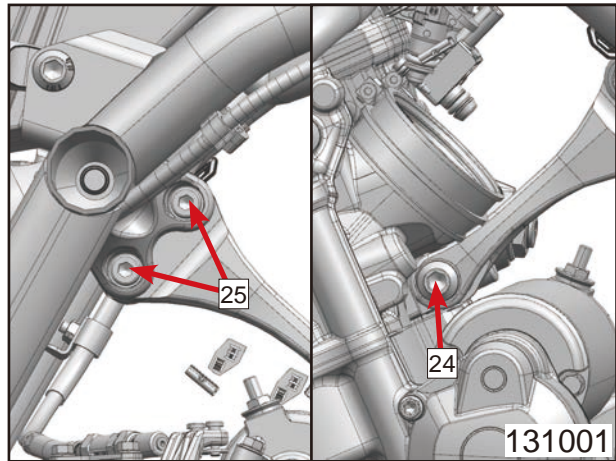

Remove screws 26.  
Remove screws 27.

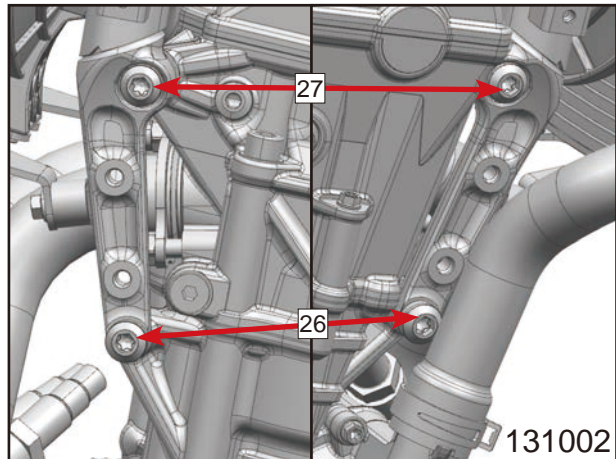

Remove screws 28.

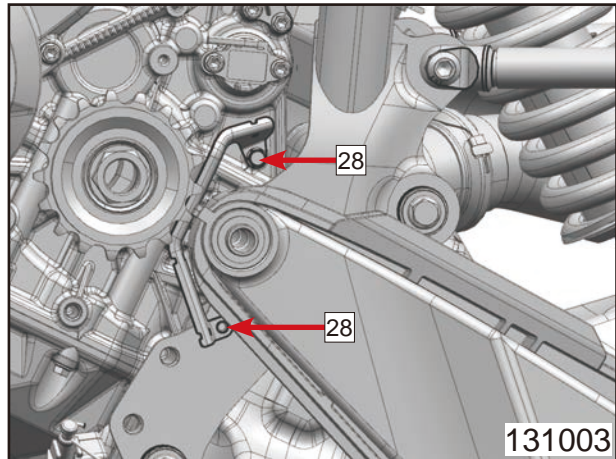

Remove the engine.

## NOTE

The help of an assistant is useful in this step.  
Make sure that the motorcycle is sufficiently secured against falling over.  
Cover the components them against damage.

## 13.3 Engine Disassembly

### 13.3.1 Draining the Engine Oil

Remove oil drain plugs (1) with the magnet, O-rings, and oil screen. Completely drain the engine oil.

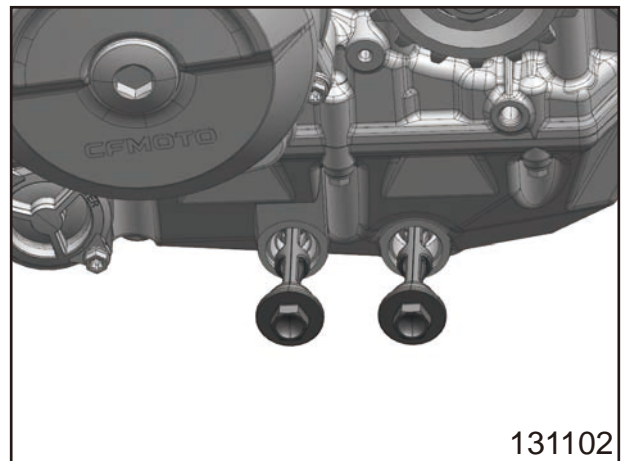
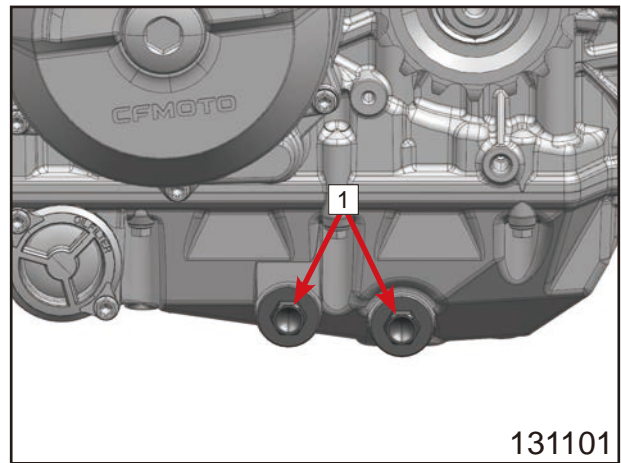

### 13.3.2 Removing the Oil Filter

Remove screws (1).

Take off oil filter cover (2) with the O-ring.

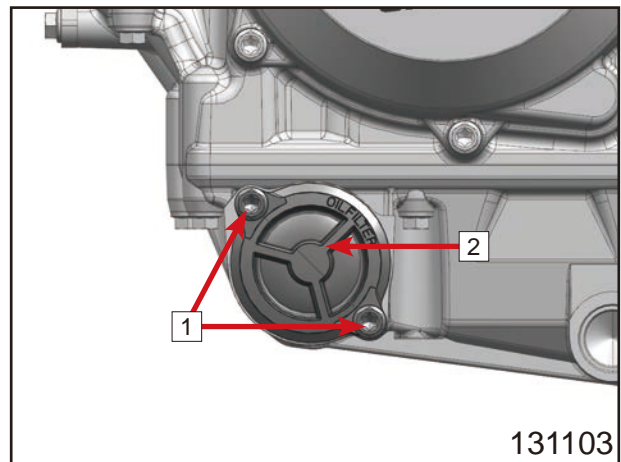

Remove oil filter (3).

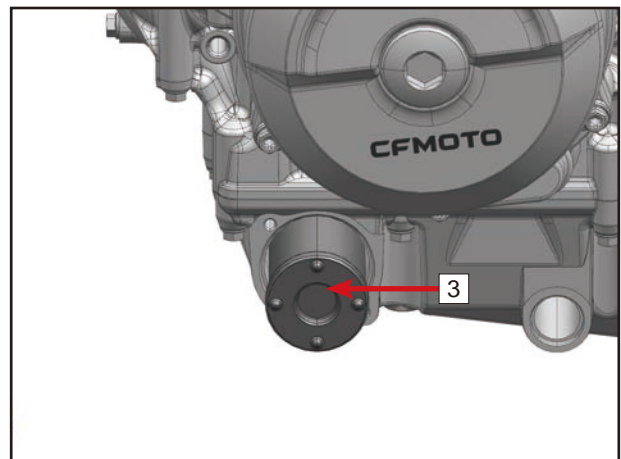

© CFMOTO Powersports, Inc. This manual is subject to all applicable copyright laws. Reproduction or duplication in any form, whole or in part, is strictly prohibited.

## 13.3.3 Removing the Starter Motor

Remove screw (1).

Take off the starter motor.

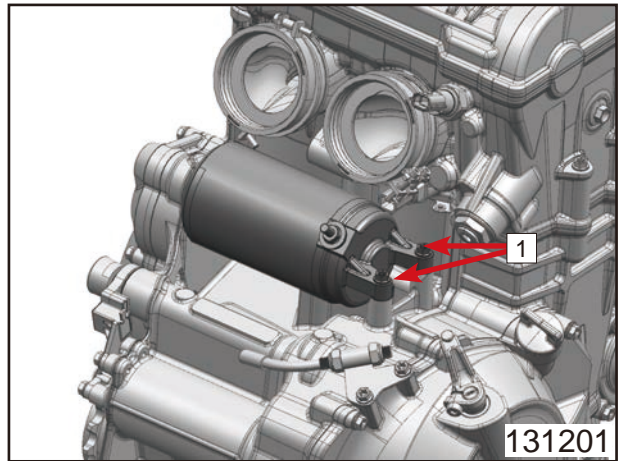

## 13.3.4 Removing the Valve Cover

Remove screws (1).

Remove ignition coils (2).

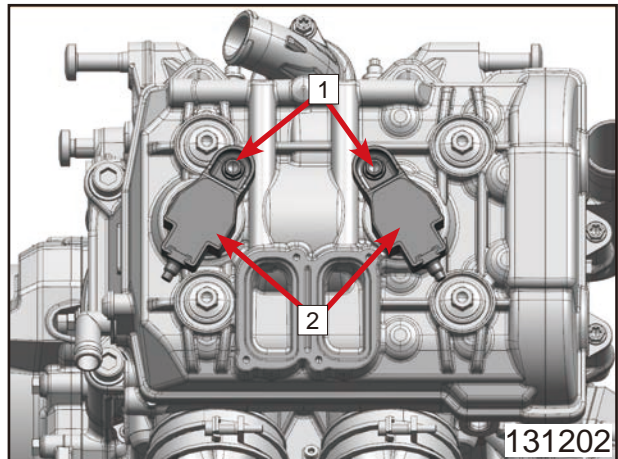

Remove screw (3) with retaining bracket.

Pull off bleeder flange (4).

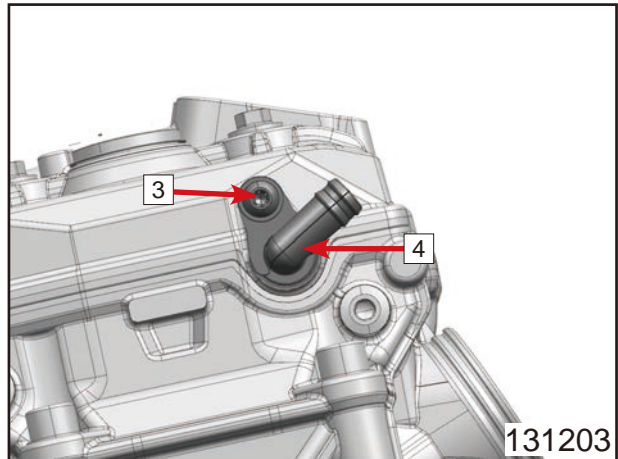

Remove screws (5) with gaskets.

Take off the valve cover with the valve cover seal.

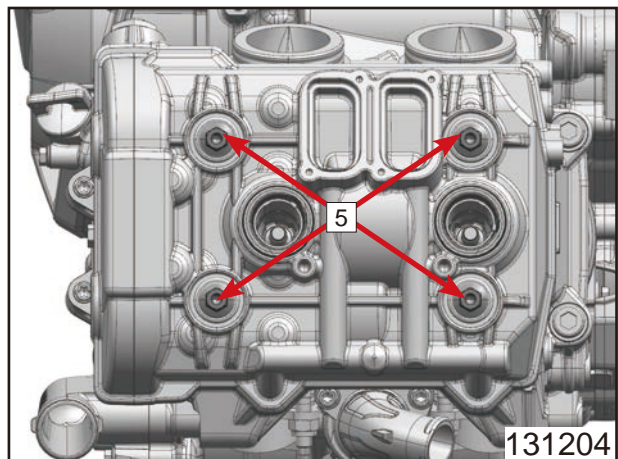

## 13.3.5 Removing Shift Shaft Sensor

Remove screws (1).

Take off the shaft sensor (2).

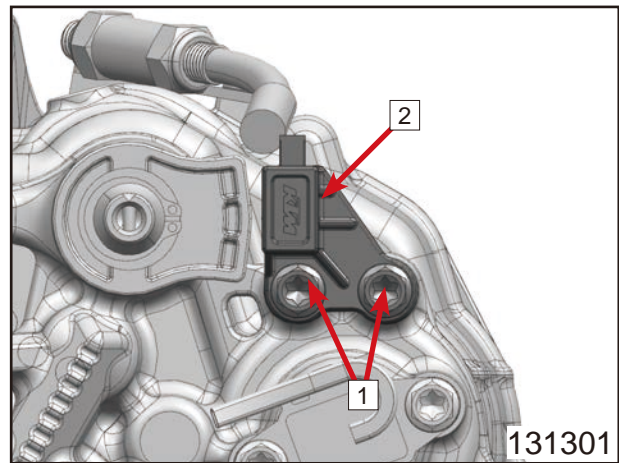

Remove lock ring (3).

Remove washer (4).

Remove locating washer (5).

Take off magnetic holder (6).

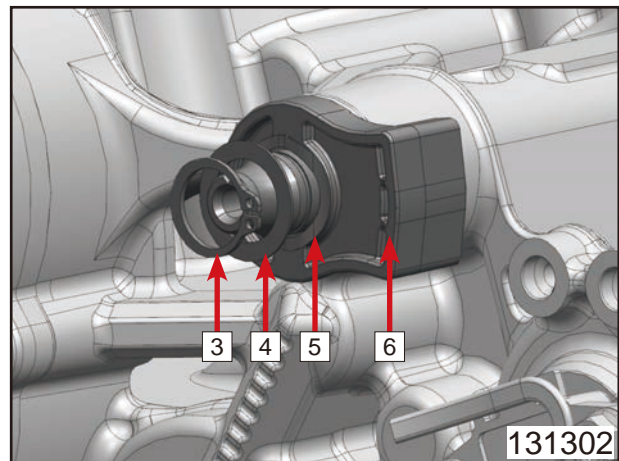

Remove pin (7).

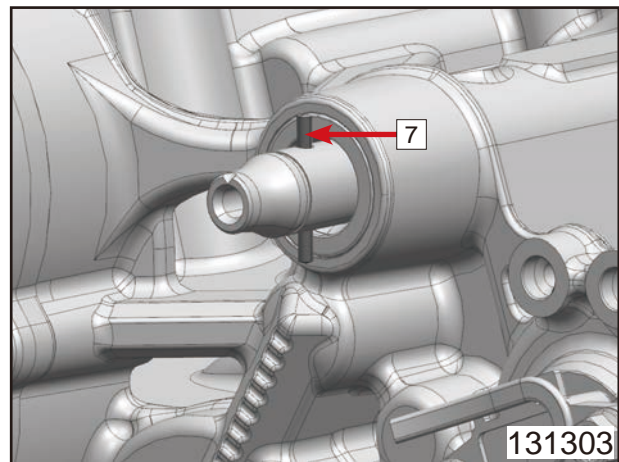

## 13.3.6 Removing the Gear Position Sensor

Remove the cable tie.

Remove screws (1).

Take off gear position sensor (2).

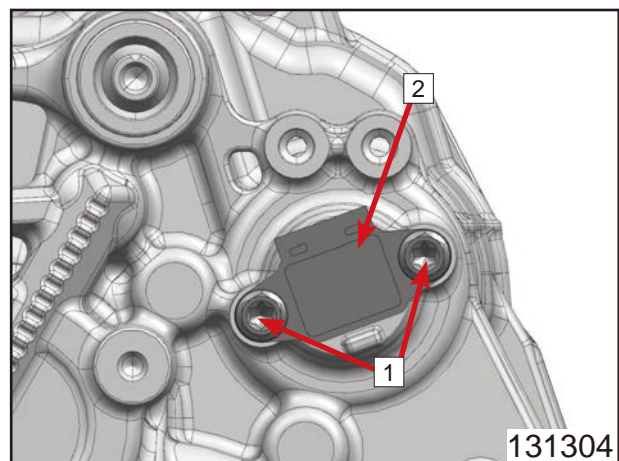

## 13.3.7 Removing the Spacer

Remove spacer (1) of the countershaft.  
Remove the O-ring.

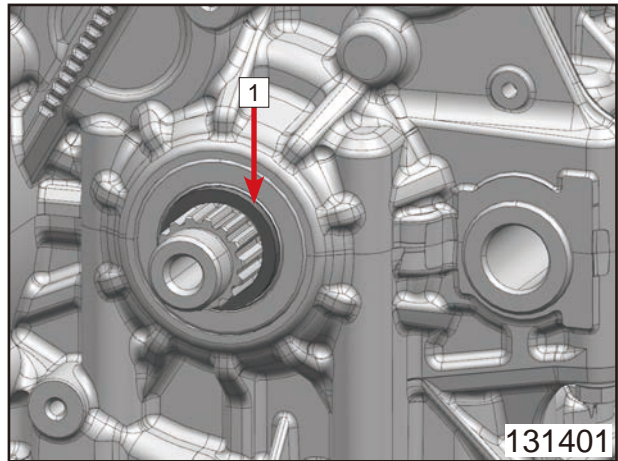

## 13.3.8 Removing the Alternator Cover

Remove screw plug (1) with the O-ring.

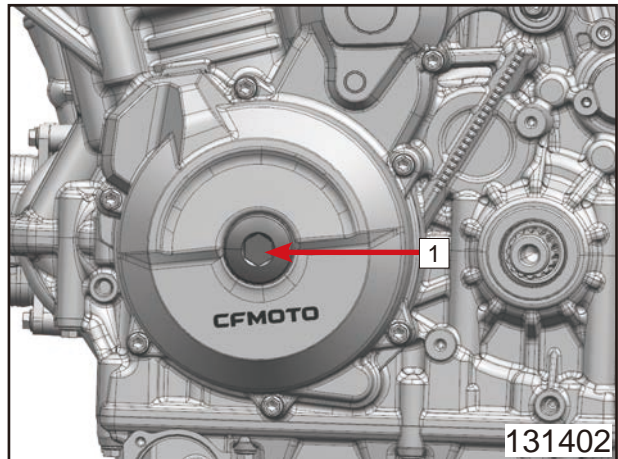

Remove screws (2) and (3).

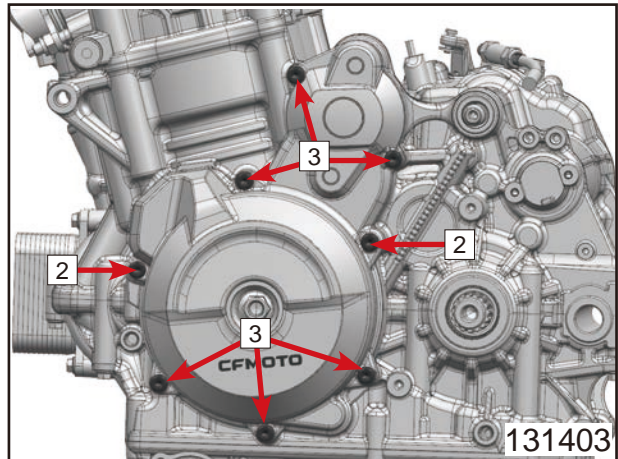

Remove the alternator cover.  
Take off alternator cover gasket (4).  
Remove dowels (5).

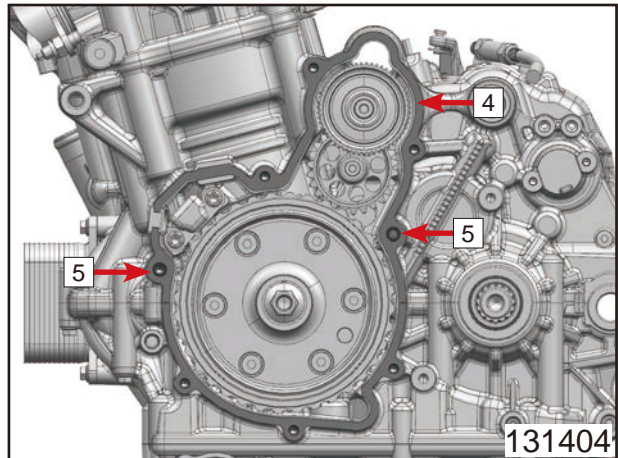

## 13.3.9 Removing the Torque Limiter and Starter Intermediate Gear

Take off torque limiter (1) with washer.

<b>NOTE</b>
-------------

The washer usually sticks to the engine case.
---

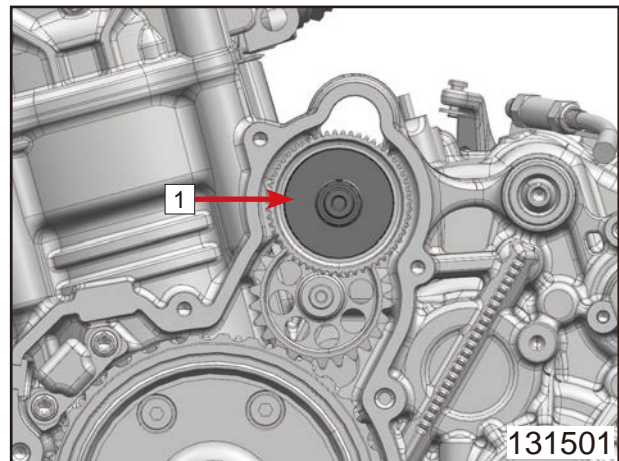

Take off shaft (2) and starter intermediate gear (3) with needle bearing and washers (4).

<b>NOTE</b>
-------------

The rear washer usually sticks to the engine case.
--

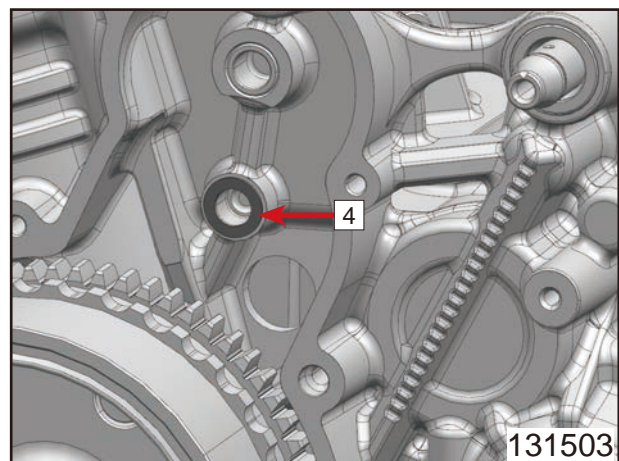
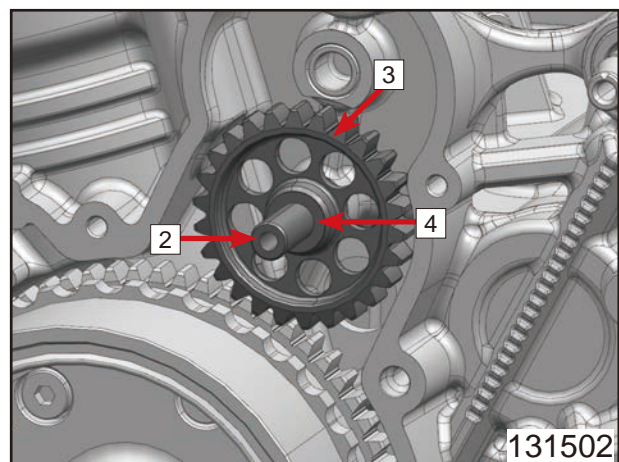

## 13.3.10 Removing the Ignition Pulse Generator

Remove screws (1).

Pull cable sleeve (2) out of the engine case.

Remove the ignition pulse generator.

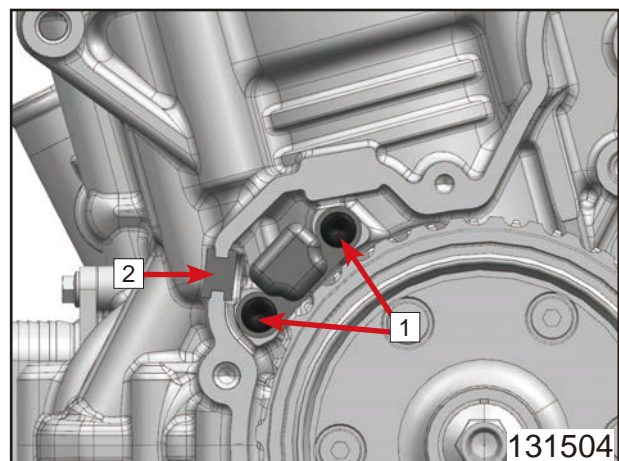

## 13.3.11 Removing the Heat Exchanger

Remove screws (1).

Take off heat exchanger (2).

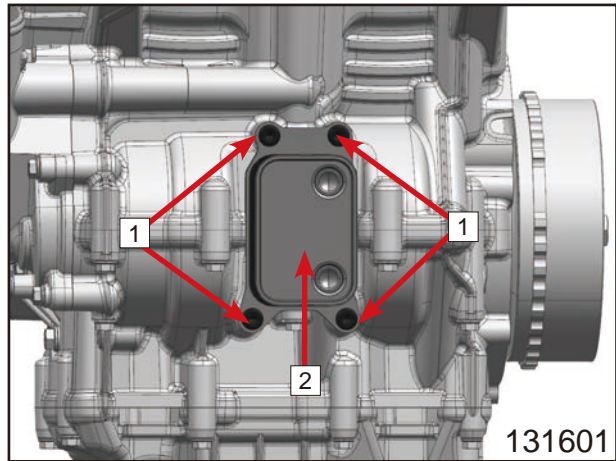

Remove gasket (3).

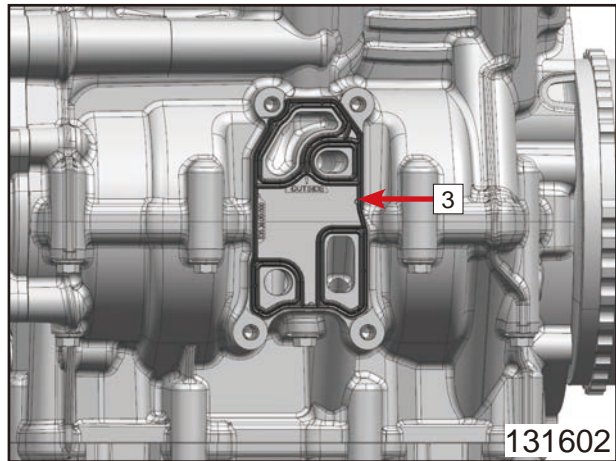

## 13.3.12 Removing the Thermostat

Remove screws (1).

Take off the thermostat case.

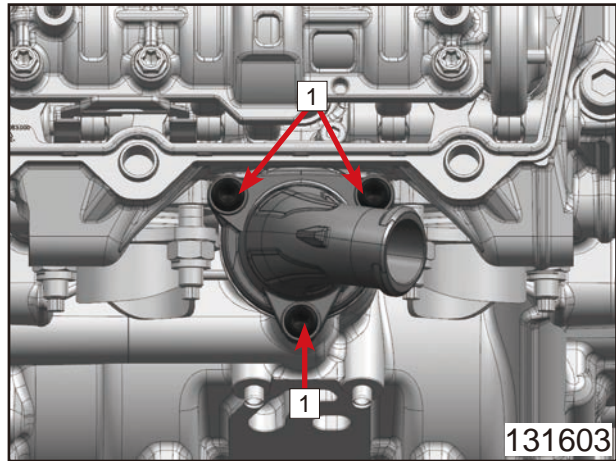

Remove thermostat (2).

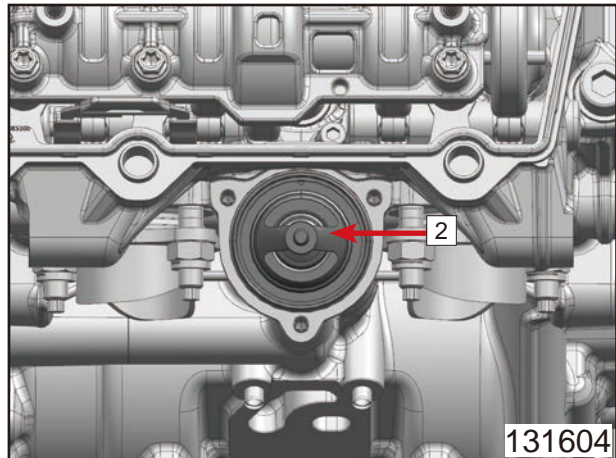

## 13.3.13 Removing the Water Pump Impeller

Remove screws (1).

Take off water pump cover with the gasket.

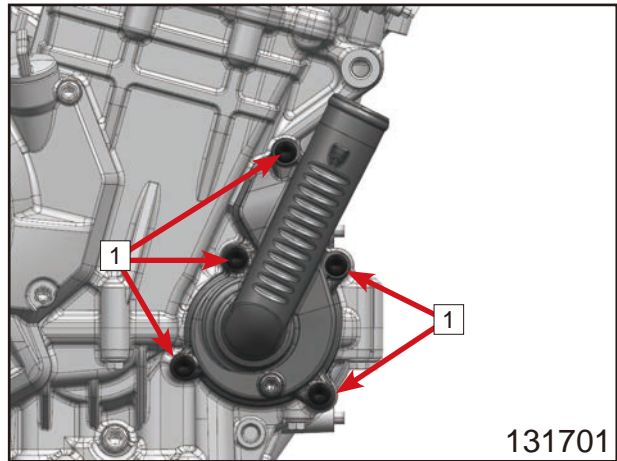

Remove dowels (2).

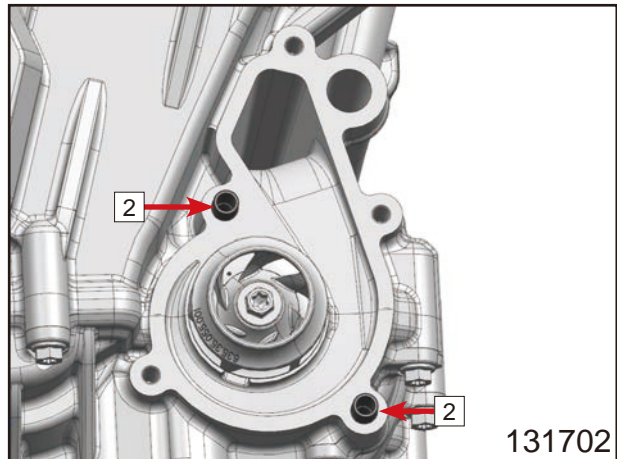

Remove screw (3).

Remove water pump impeller (4).

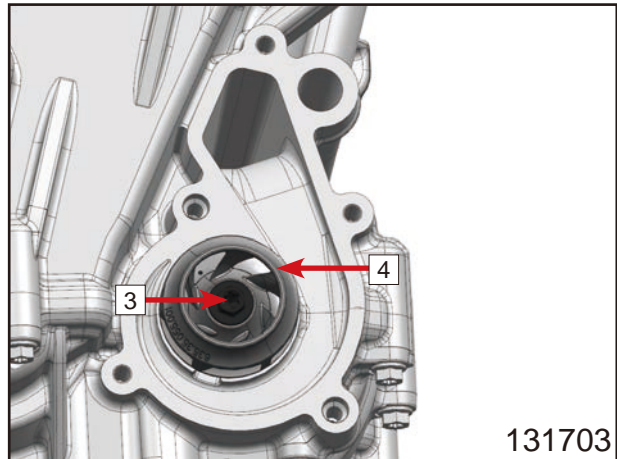

Remove from washer (5).

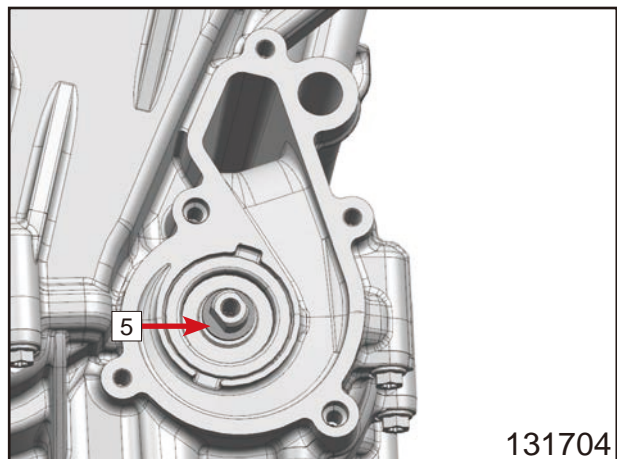

## 13.3.14 Removing the Clutch Cover

Remove screws (1).

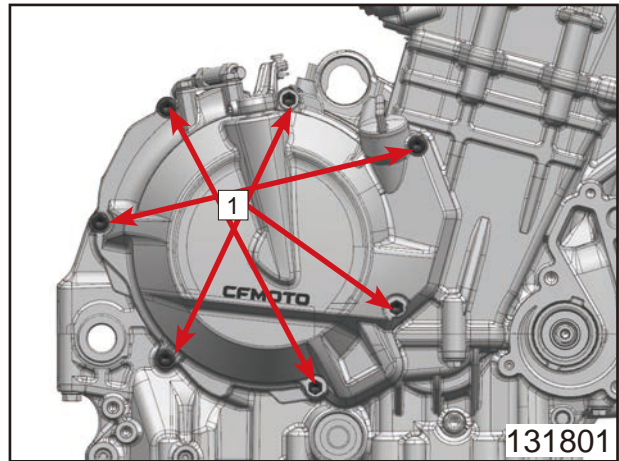

Swivel the clutch lever (2) clockwise and take off clutch cover with clutch cover gasket.

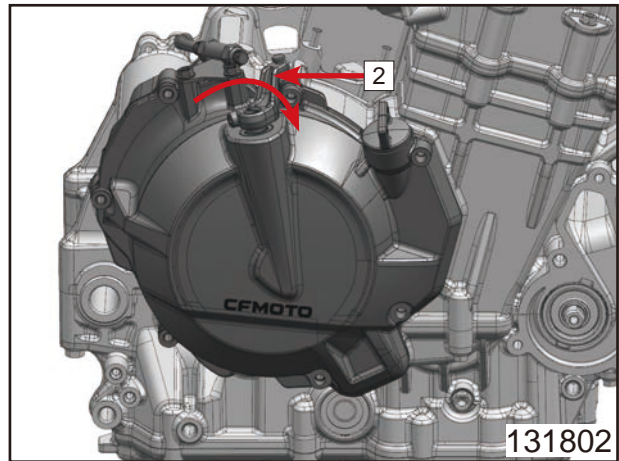

Remove dowels (3).

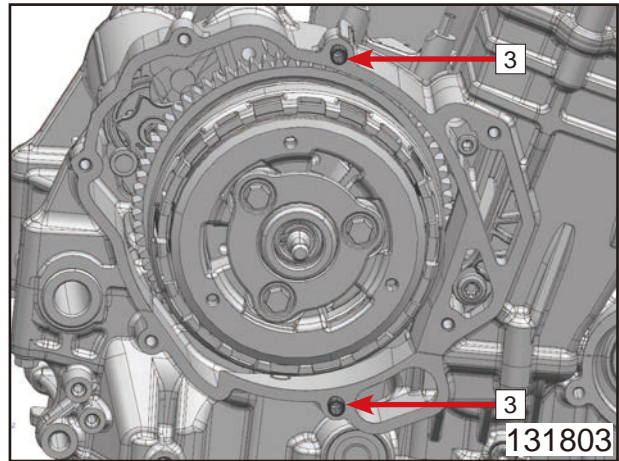

## 13.3.15 Removing the Clutch Discs

Remove screws (1).

Take off clutch center (2) and the springs.

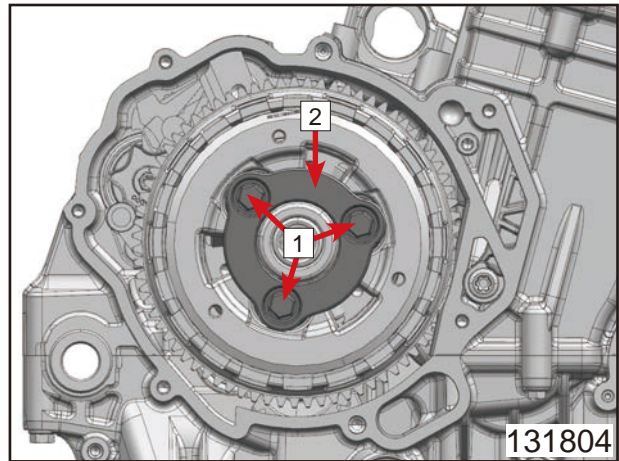

Remove clutch pressure cap (3).

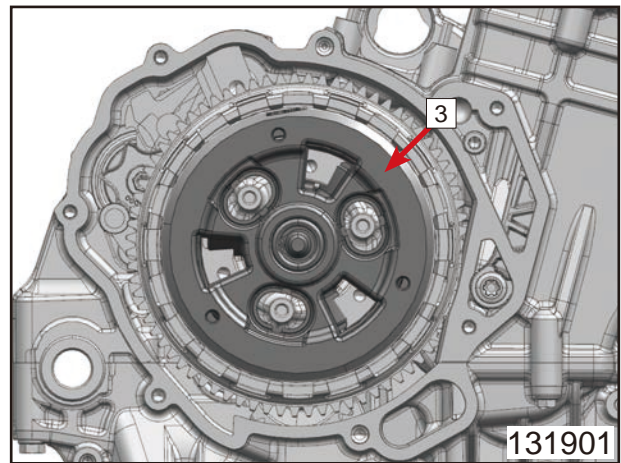

Remove clutch discs (4), support ring, and pretension ring.

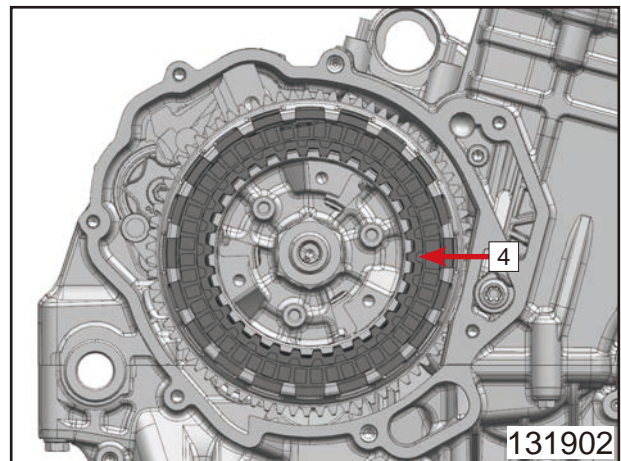

### 13.3.16 Removing the Clutch Basket

Lock crankshaft with crankshaft locking screw. (Refer to Section 13.3.20.)

Hold the inner clutch hub (1) with the special tool (A) (Clutch stop tool).

Clutch Stop Tool  
(See Section 13.1 for details.)

Remove nut (2) with the washer.  
Remove the tool (A).

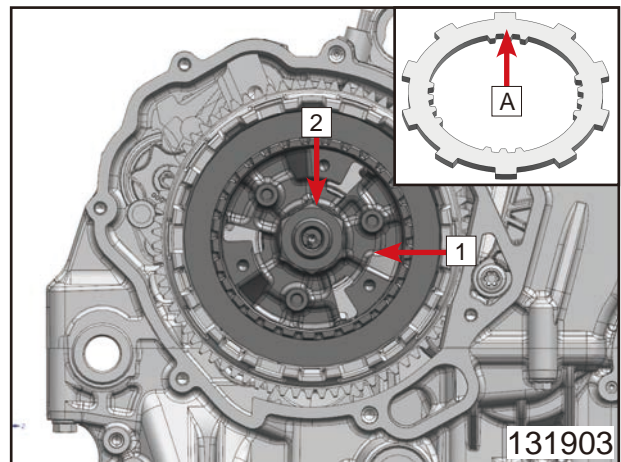

Take off inner clutch hub (1) and washer (3).

**NOTE**

The washer usually sticks to the inner clutch hub.

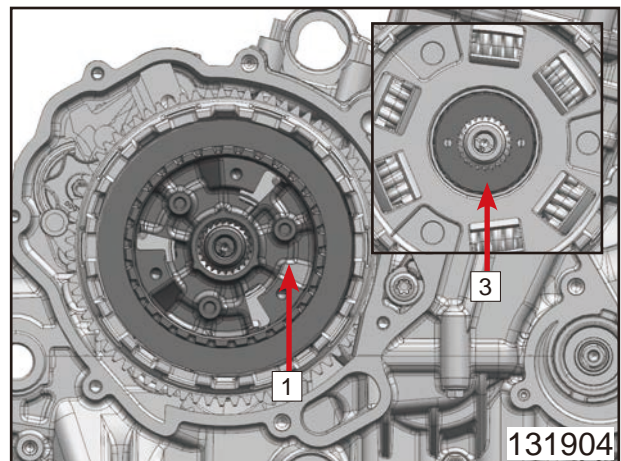

# CFMOTO

Remove needle bearing (4).

**NOTE**

Use a magnetic rod to make disassembly easier.

Do not use pliers, as otherwise the needle bearing will be damaged.

Take off clutch basket (5).

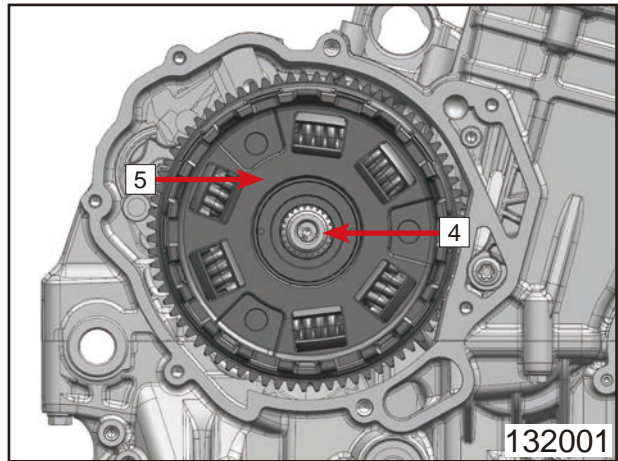

Remove washer (6).

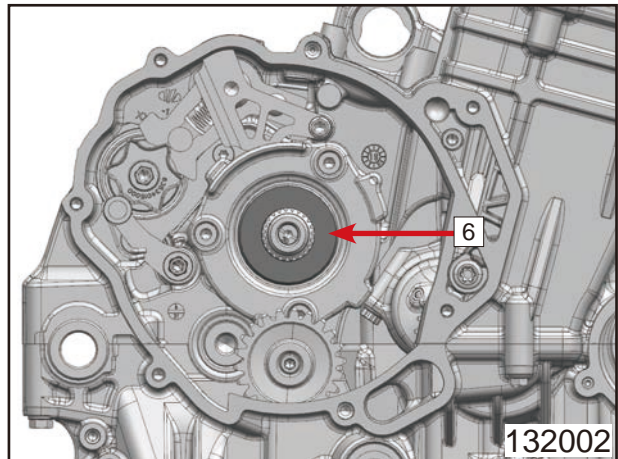

Remove screw (7).

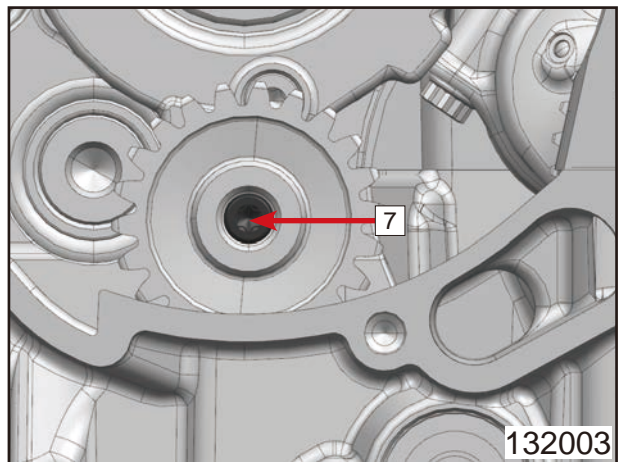

Take off intermediate gear (8) with collar bushing (9).

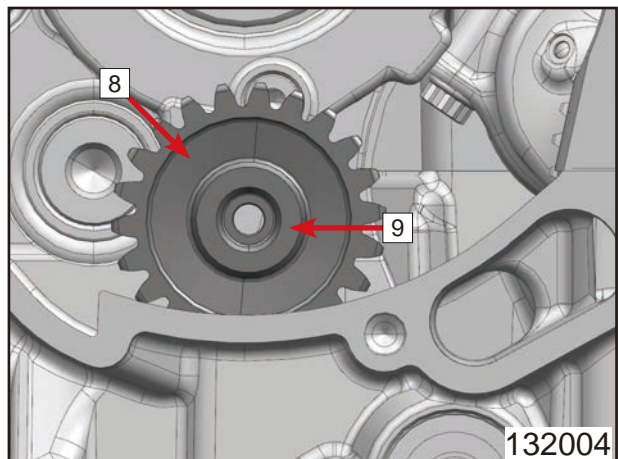

## 13.3.17 Removing Locking Lever

Remove screw (1).

Take off locking lever (2) with the sleeve and spring.

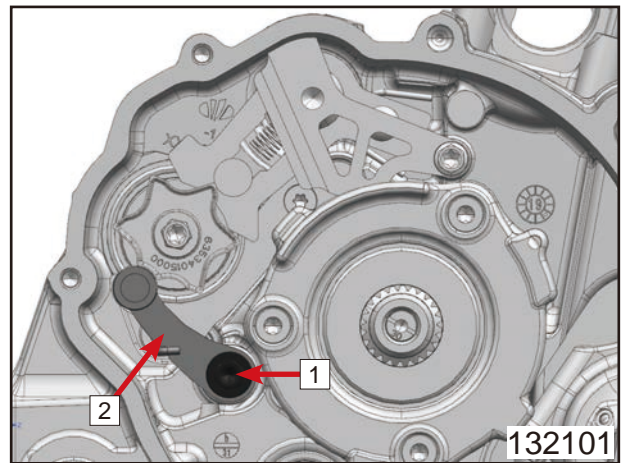

## 13.3.18 Removing the Shift Shaft

Remove screw (1).

Take off retaining bracket (2).

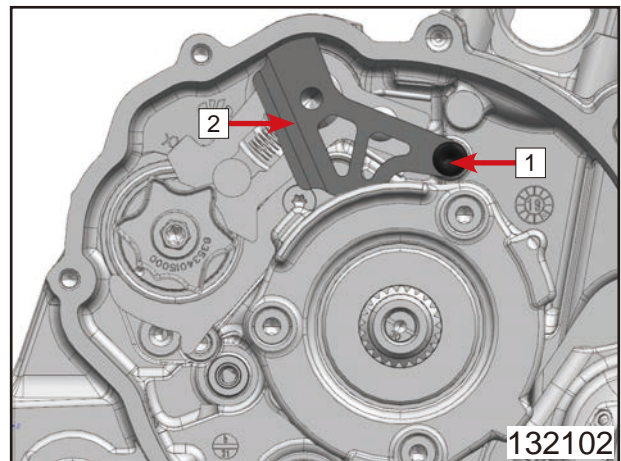

Twist shift drum until the neutral position (A) is aligned with the sliding plate (3).

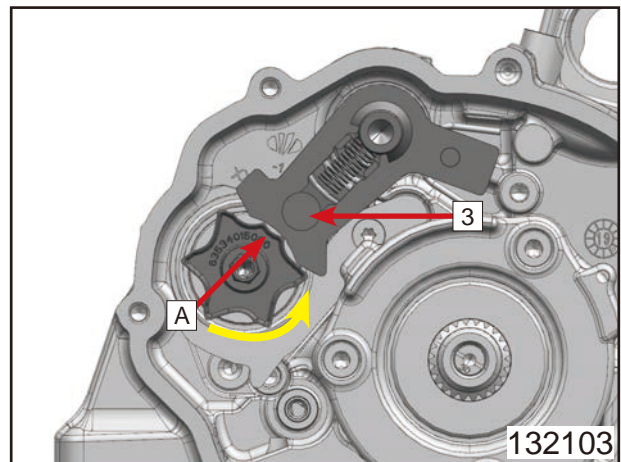

Push sliding plate (3) away from shift drum locating unit (4).

Remove shift shaft (5) with washer (6)

<b>NOTE</b>
The washer usually sticks to the engine case.

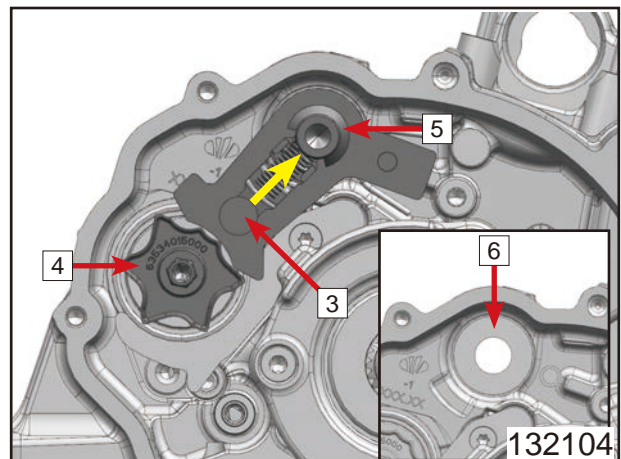

## 13.3.19 Removing the Spark Plugs

Remove spark plug shaft inserts (1) with the gaskets.

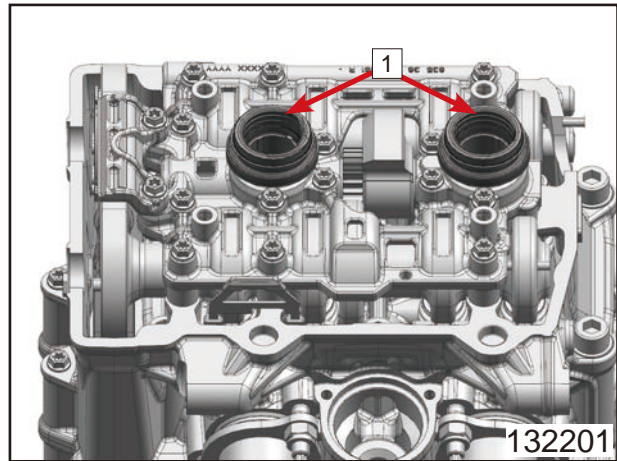

Remove the spark plugs (2).

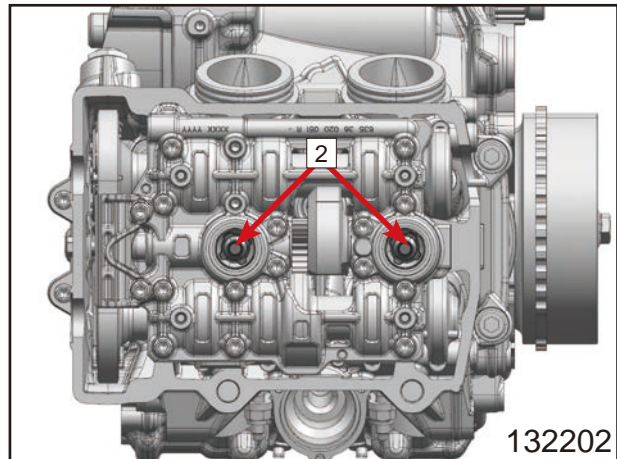

## 13.3.20 Removing the Camshafts

Turn the crankshaft counterclockwise and set it to ignition top dead center of cylinder 2.

The OT2 marking (A) are aligned with the sealing surface.

<b>NOTE</b>
The OT2 markings are dot markings.

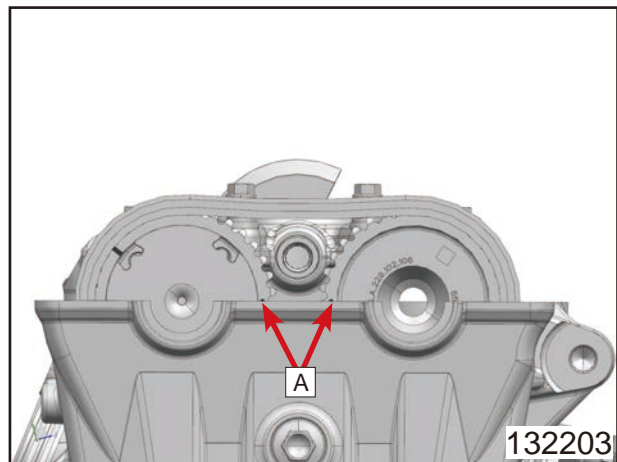

Remove cam lever clip (1).

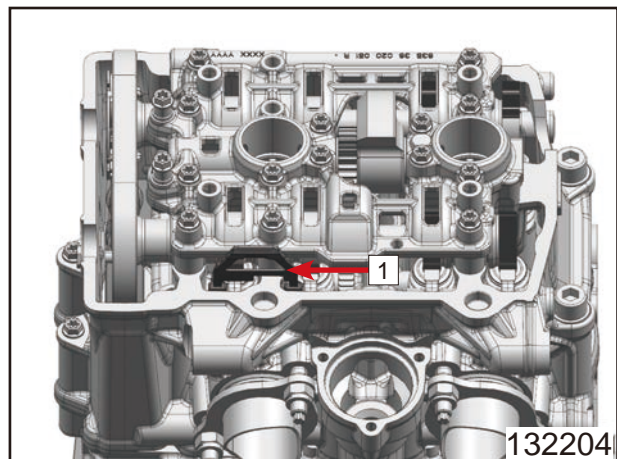

Push exhaust cam lever (2) on cylinder 2 to the side.

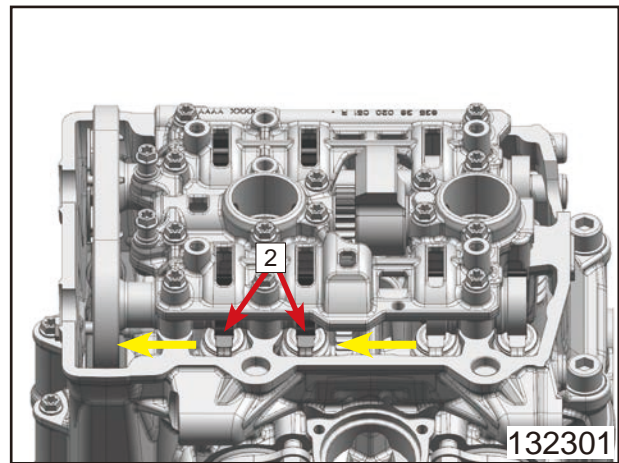

Set the crankshaft to ignition top dead center of cylinder 1.  
The OT1 marking (B) are aligned with the sealing surface.

<b>NOTE</b>
The OT1 markings are line markings.

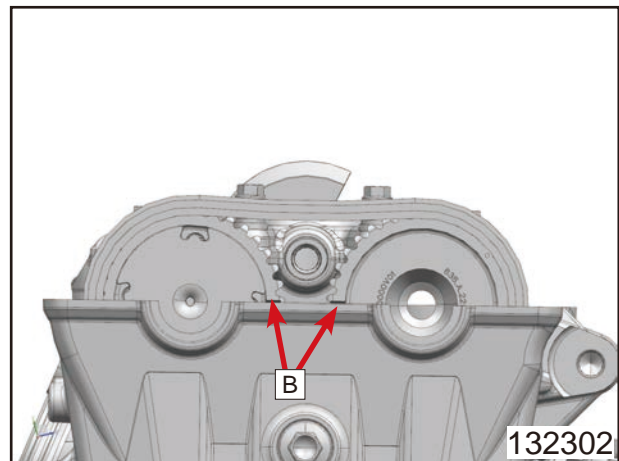

Remove screw (3) with the washer.

<b>NOTE</b>
Look through the hole to check that the position hole of the crankshaft is visible.

Mount special tool (A) (locking screw).

Crankshaft Locking Screw (See Section 13.1 for details.)
---

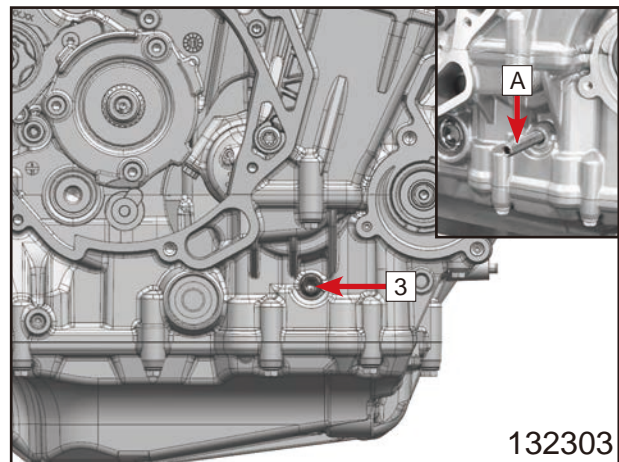

Remove screw (4) with the O-ring.  
Take off timing chain tensioner (5) with O-ring.

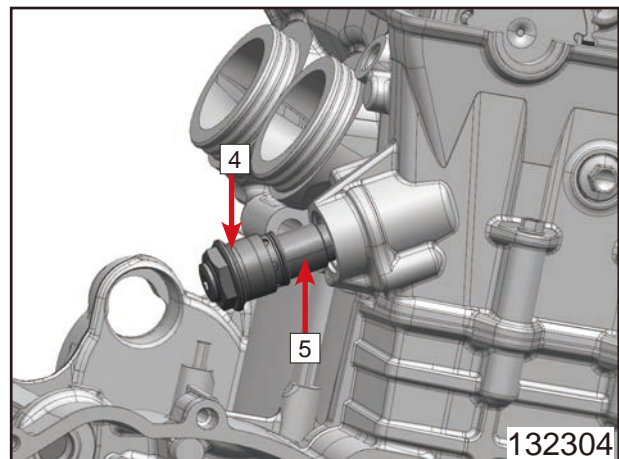

© CFMOTO Powersports, Inc. This manual is subject to all applicable copyright laws. Reproduction or duplication in any form, whole or in part, is strictly prohibited.

Loosen and remove screws (6) from the outside to the inside.  
Take off camshaft bearing bridge with balancer shaft.

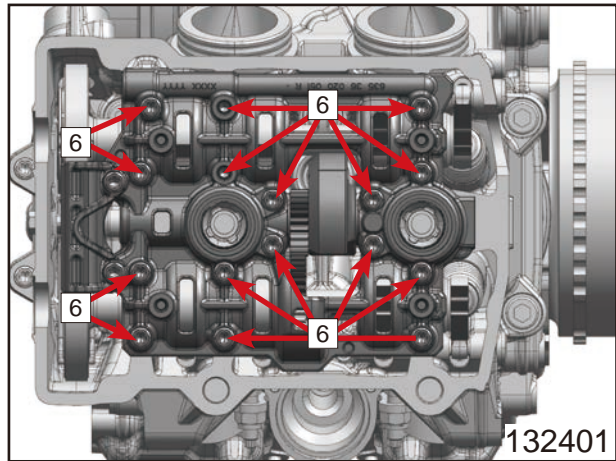

Raise the camshafts at the rear and take the timing chain off the rear sprocket.  
Remove the camshafts.

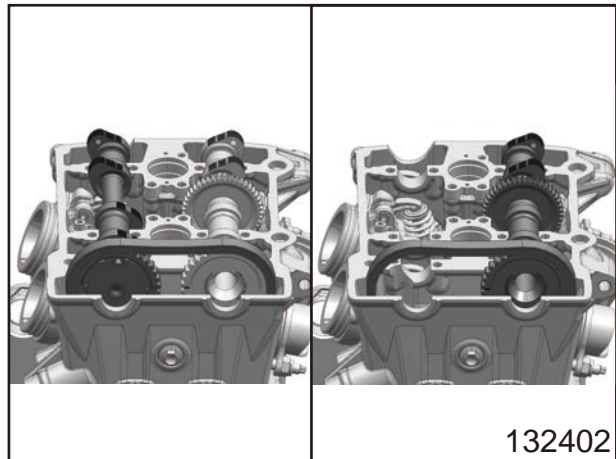

### 13.3.21 Removing the Cylinder Head

Remove screw (1) with gasket.  
Remove screw (2).

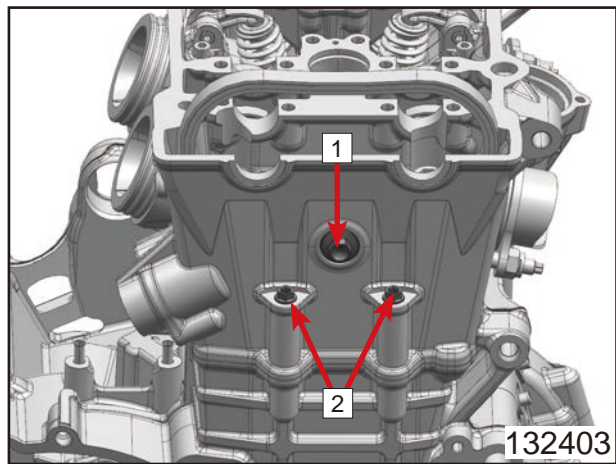

Loose screws (3) in a crisscross pattern and remove them with the washers.  
Take off the cylinder head.

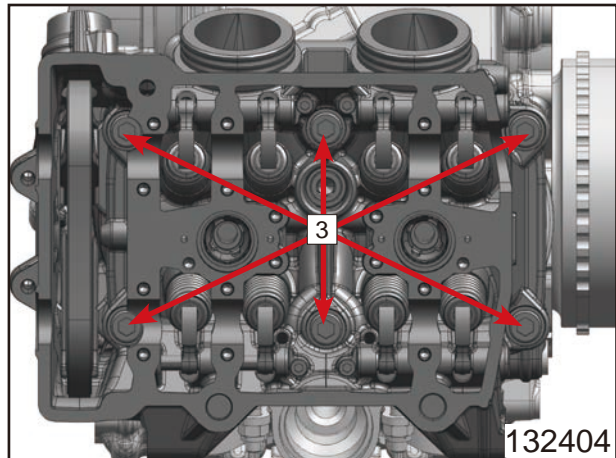

Take off cylinder head gasket (4).  
Remove dowels (5).

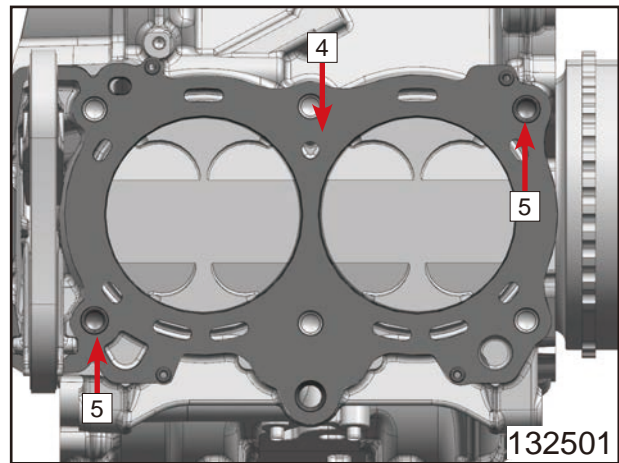

### 13.3.22 Removing the Timing Chain Rails

Remove guide rail (1) from the top.  
Remove screw (2).  
Remove tensioning rail (3) with support bushing upward.

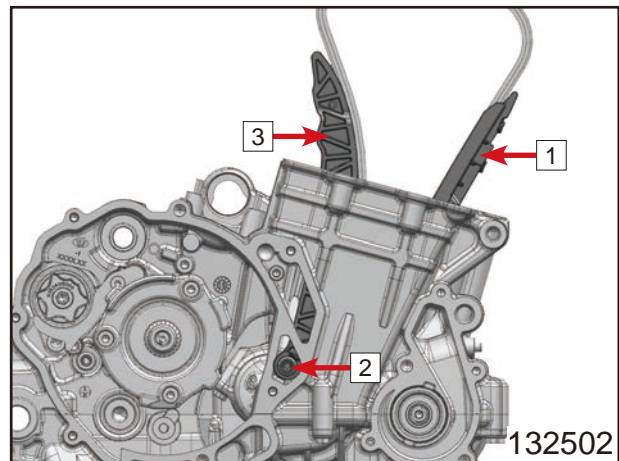

### 13.3.23 Removing the Rotor

Remove screw (1).  
Mount special tool (A) (Magneto rotor removal tool) on the rotor, then pull off the rotor by turning the screw in.

Magneto Rotor Removal Tool  
(See Section 13.1 for details.)

Remove the special tool (A).

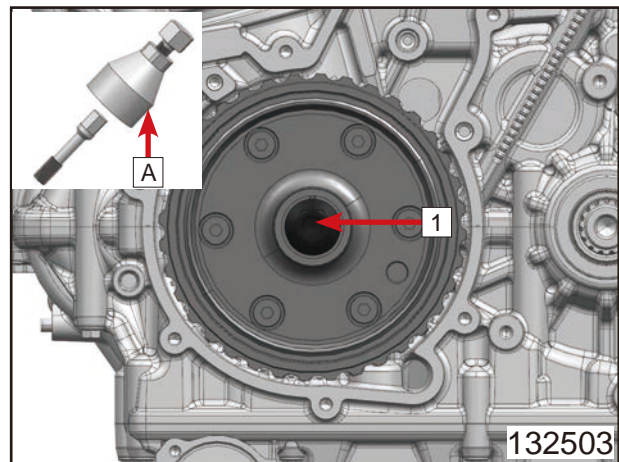

Remove woodruff key (2).

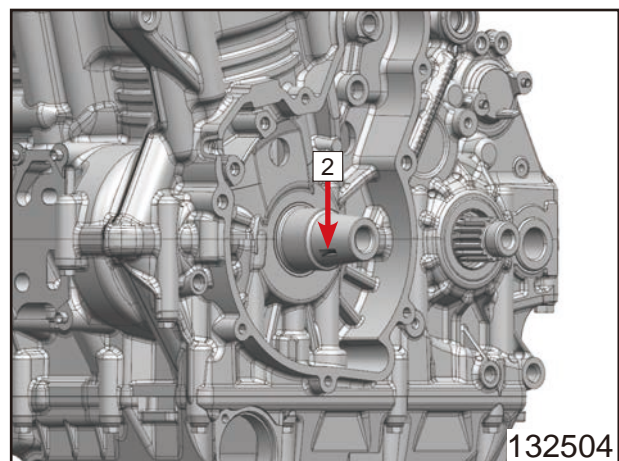

# CFMOTO

Remove special tool (A) (locking screw).

Crankshaft Locking Screw  
(See Section 13.1 for details.)

Replace screw (B) with the washer.

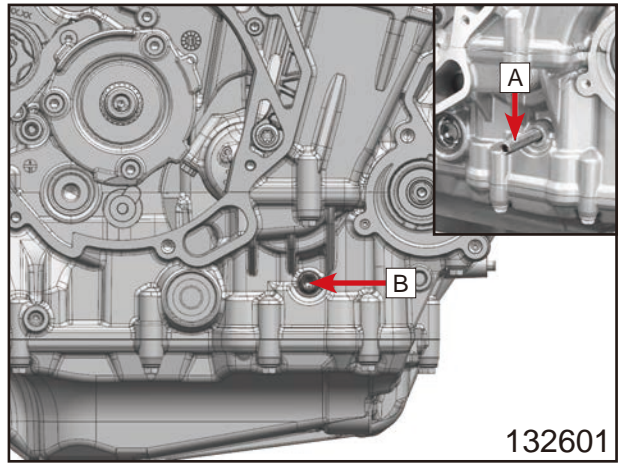

Take off freewheel gear (3) from rotor (4).

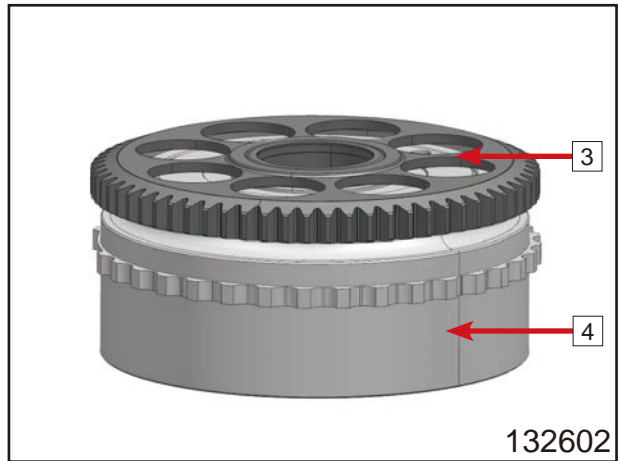

### 13.3.24 Removing the Oil Pan

Remove screws (1).

Take off oil pan.

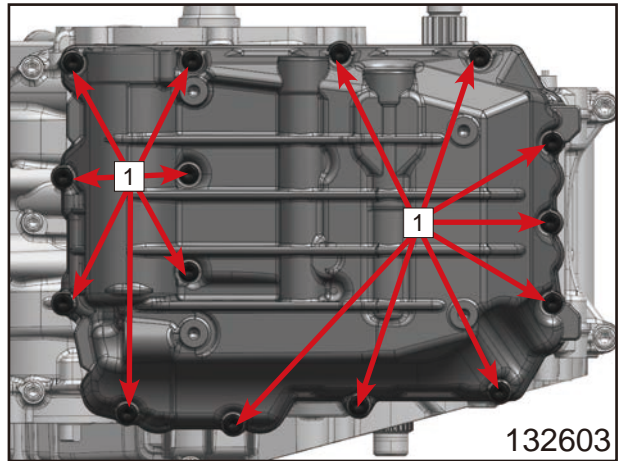

Take off gasket (2).

Remove dowels (3).

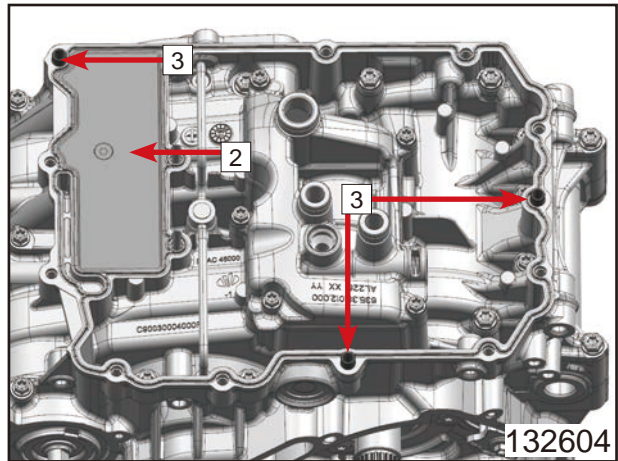

© CFMOTO Powersports, Inc. This manual is subject to all applicable copyright laws. Reproduction or duplication in any form, whole or in part, is strictly prohibited.

Remove O-ring (4).

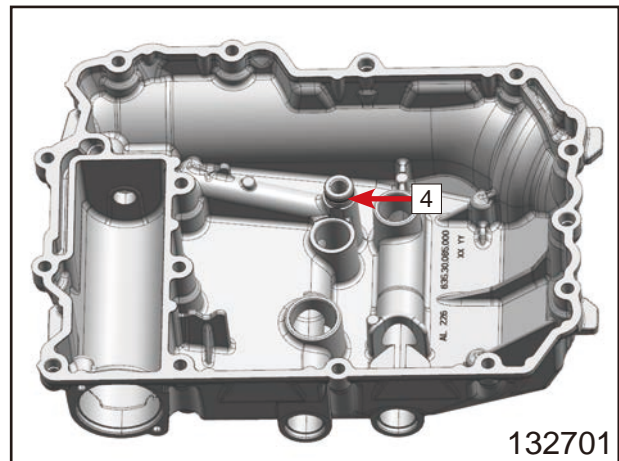

Remove screw (5).  
Remove pressure plate (6).  
Take off oil line (7).

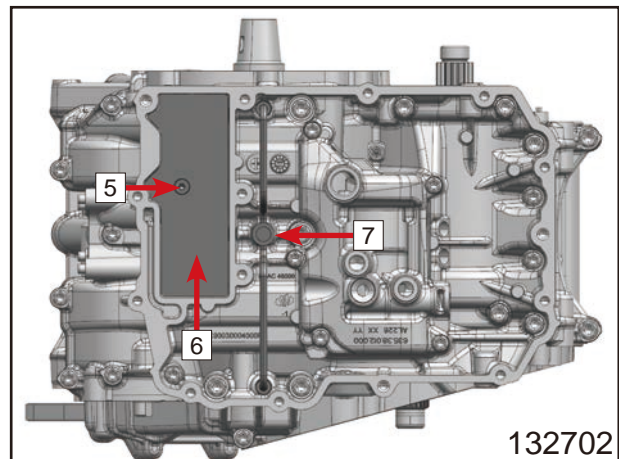

Take off O-rings (8) from the oil line.

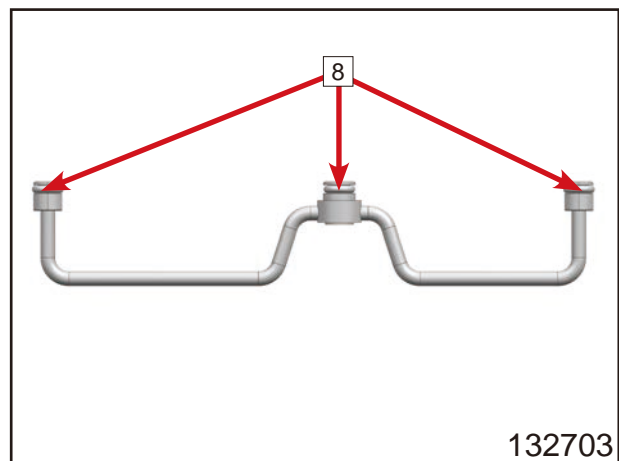

### 13.3.25 Removing the Oil Pump Unit

Remove screws (1).  
Take off oil pump unit (2).

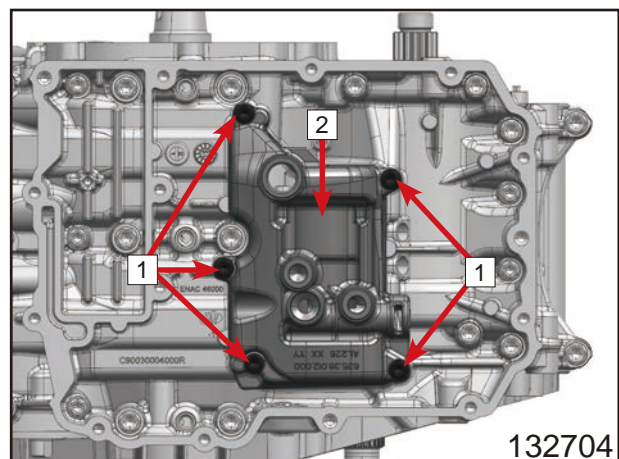

© CFMOTO Powersports, Inc. This manual is subject to all applicable copyright laws. Reproduction or duplication in any form, whole or in part, is strictly prohibited.

Remove locating pins (3).

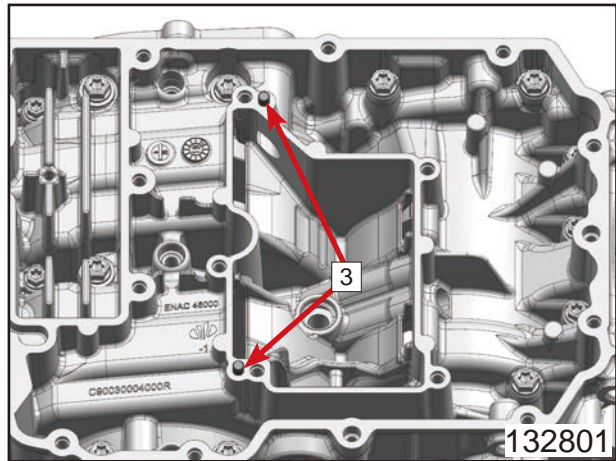

### 13.3.26 Removing the Engine Case Downwards

Remove screws (1).

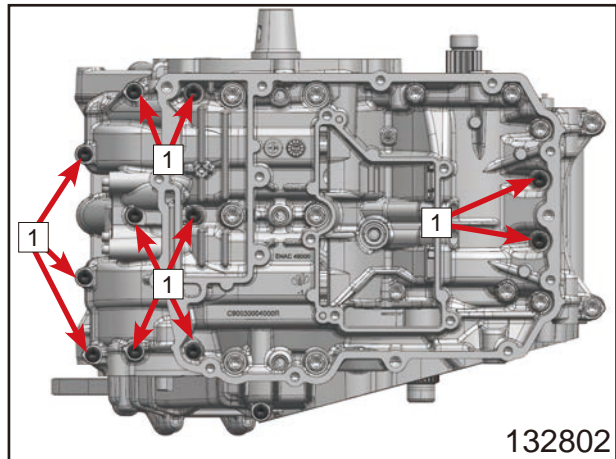

Remove screws (2).

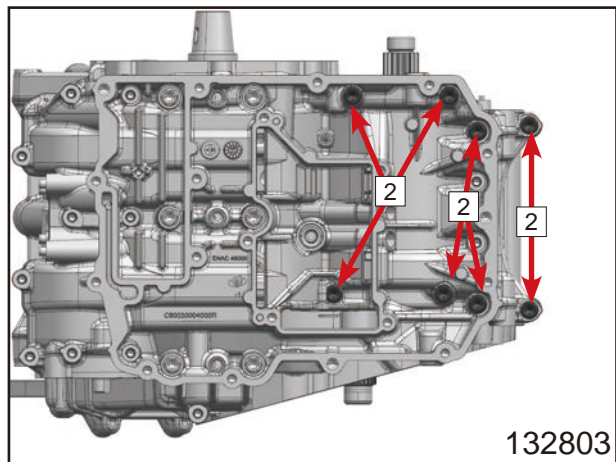

Loosen screws (3) in a crisscross pattern and remove them with the washers. Take off lower section of the engine case.

**NOTE**

Ensure that the bearing shells remain in place.

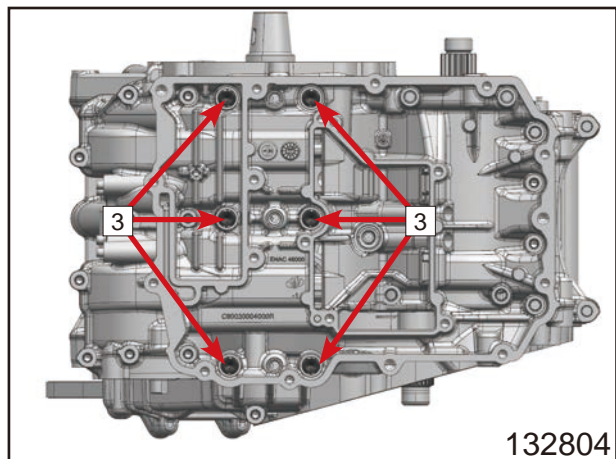

## 13 Engine

Remove balancer shaft (4) with radial shaft seal ring (5).

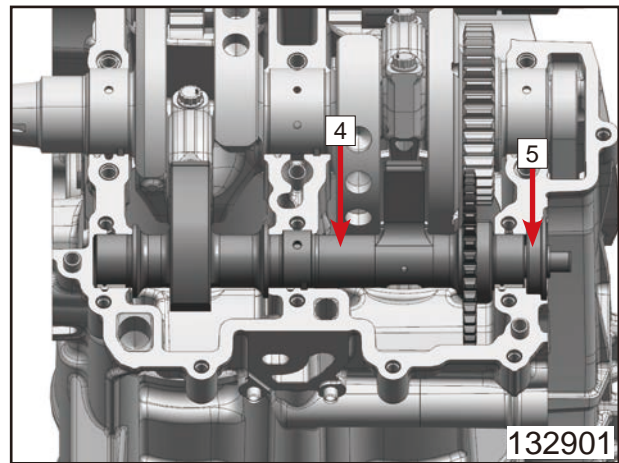

Remove screws (6).  
Take off conrod bearing covers (7) and (8).

### NOTE

The conrod bearing covers and connecting rods are marked together and must never be mixed up.

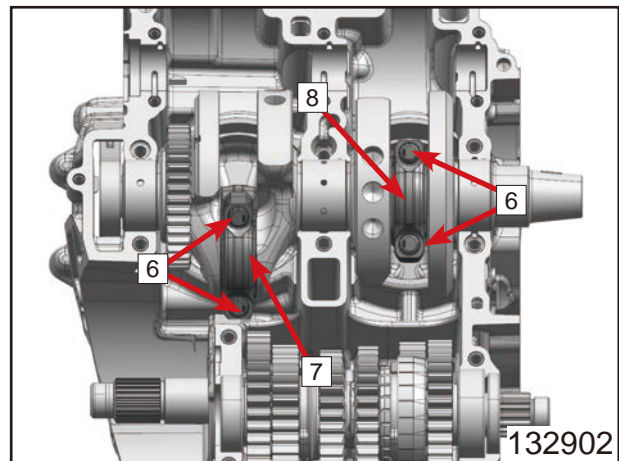

Remove crankshaft (9) with timing chain (10).

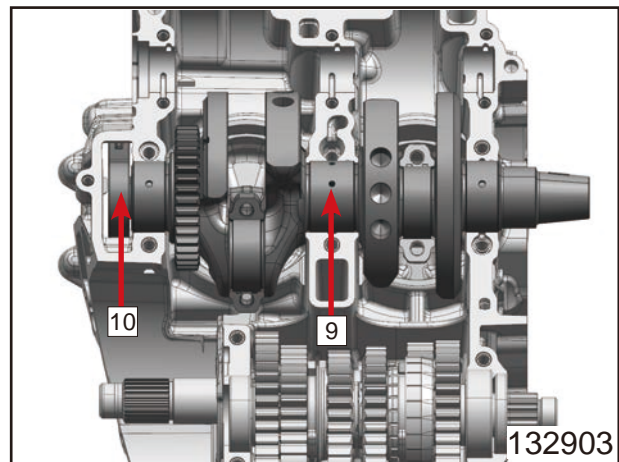

### 13.3.27 Removing the Transmission Shafts

Remove radial shaft seal ring (1).

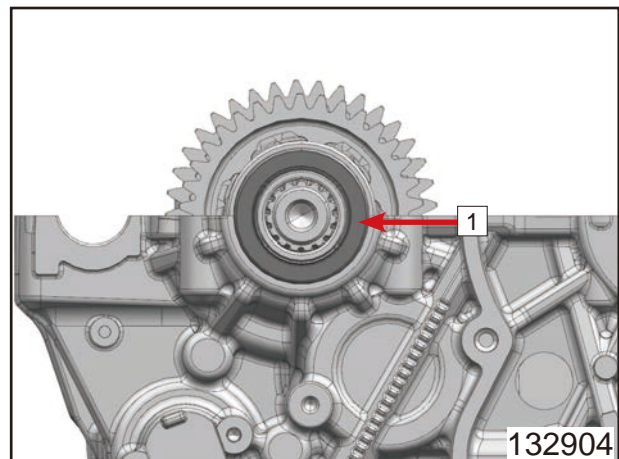

Take off countershaft (2).

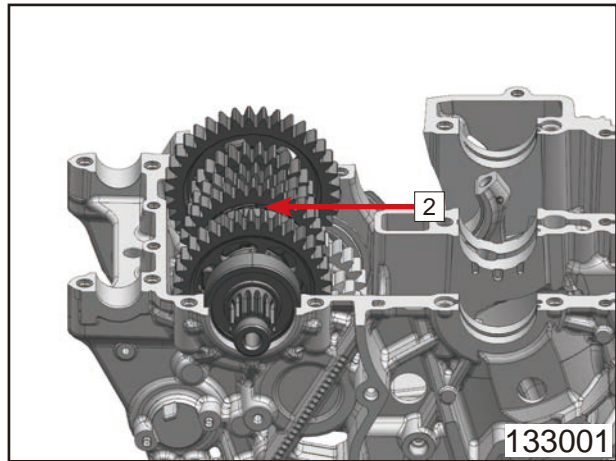

Remove screws (3).  
Take off bearing support (4) with bearing.

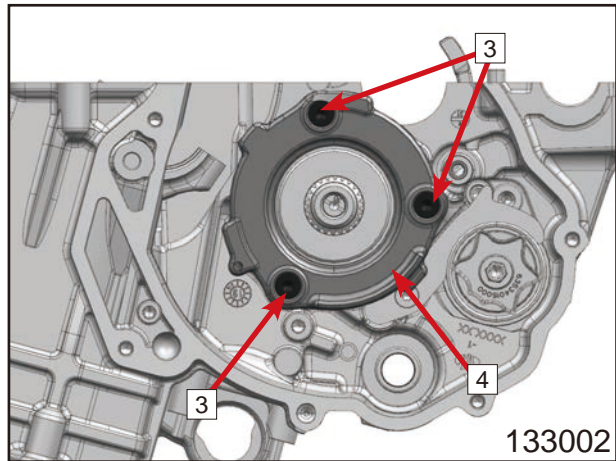

Remove screw (5).  
Take off retaining bracket (6).

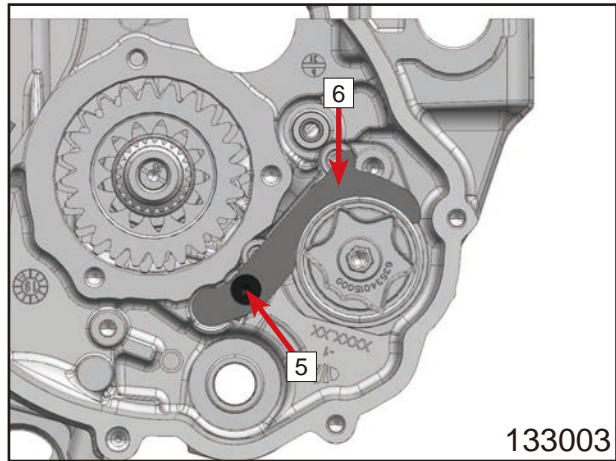

Mount appropriate M8 screw in the shift rail (7).  
Remove shift rail (7).  
Remove shift forks (8) and (9).

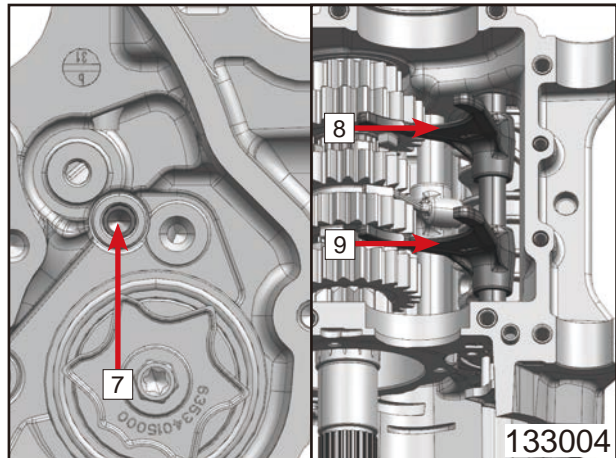

## 13 Engine

Mount appropriate M8 screw in the shift rail (10).  
Remove shift rail (10).  
Remove shift forks (11).

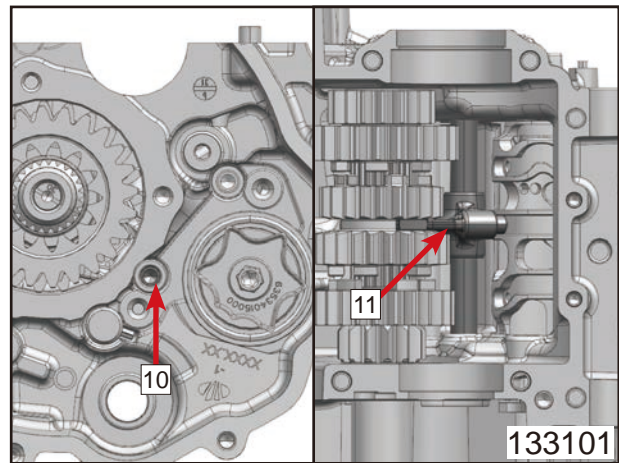

Remove main shaft (12).

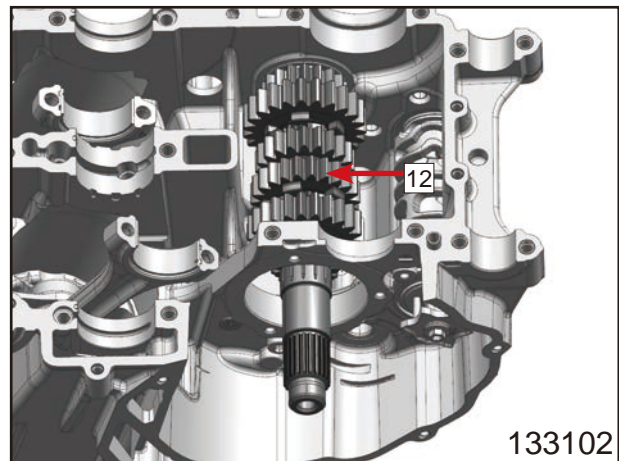

Remove shift drum (13).

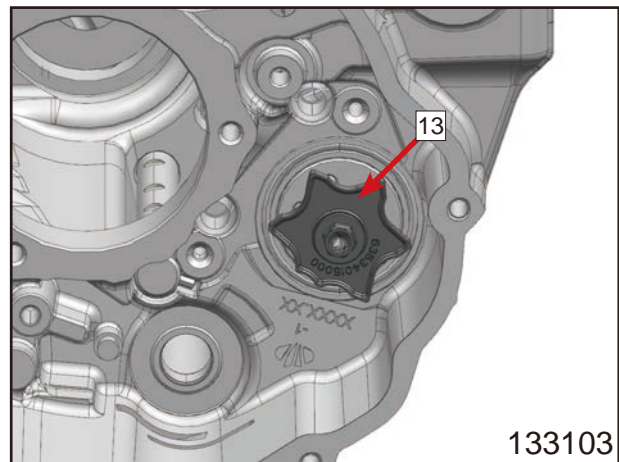

### 13.3.28 Removing Oil Spray Tube

Remove oil spray tube (1).  
Remove O-ring (2).

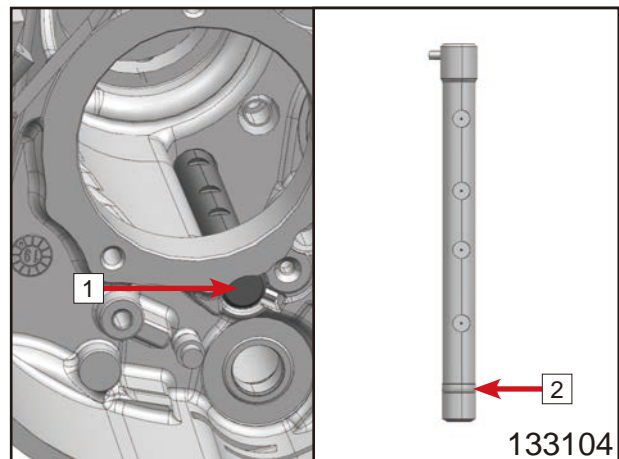

© CFMOTO Powersports, Inc. This manual is subject to all applicable copyright laws. Reproduction or duplication in any form, whole or in part, is strictly prohibited.

## 13.3.29 Removing the Piston

Swing the upper section of the engine case upward.

Mark the piston (1) and (2).

Remove any deposits in the upper area of the cylinders.

### NOTE

Ensure that the cylinders are not damaged.

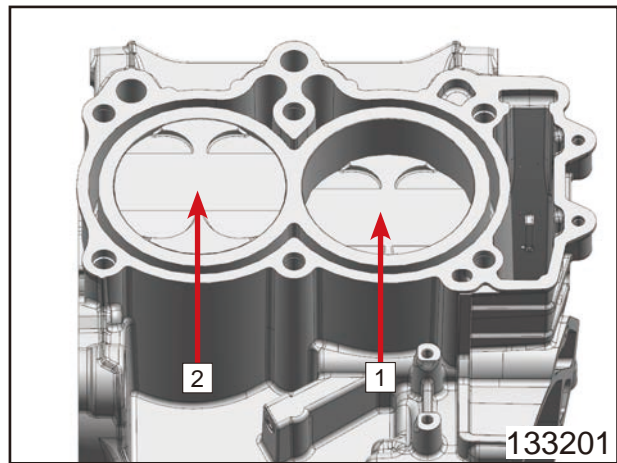

Remove piston with connecting rod upward out of the cylinder.

### NOTE

Make sure that the connecting rod does not damage the cylinder.

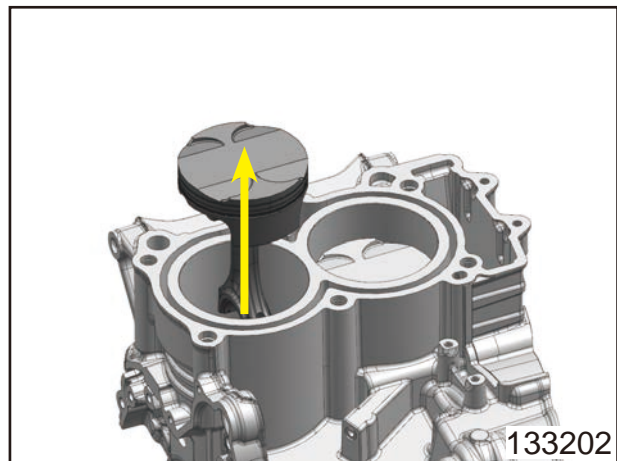

Clamp connecting rod in the vise.

**Guideline: Use soft jaws.**

Remove piston ring lock (3).

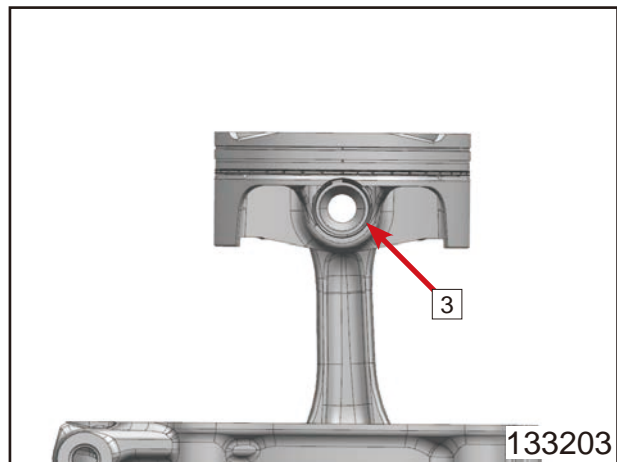

Remove piston pin (4).

Take off the piston.

Make the piston and connecting rods belonging together correspondingly.

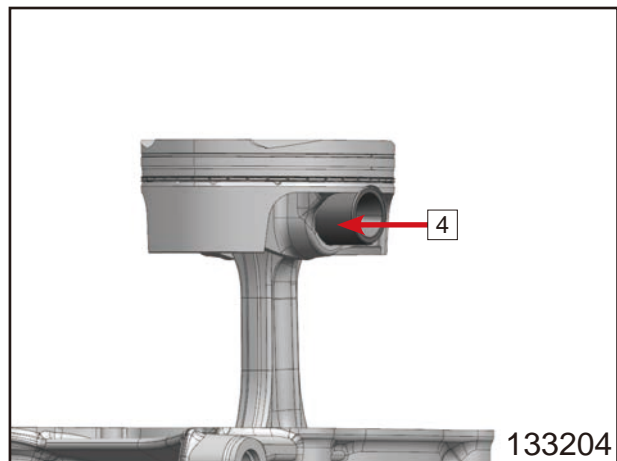

## 13.4 Working on Individual Parts

### 13.4.1 Checking the Radial Clearance of Crankshaft Bearings

Remove any remnants of sealing compound and clean the sections of the engine case thoroughly.

Clean bearing shells (1) and (2).

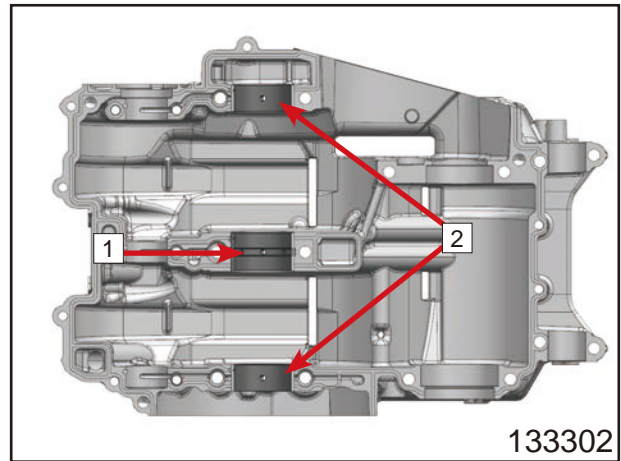
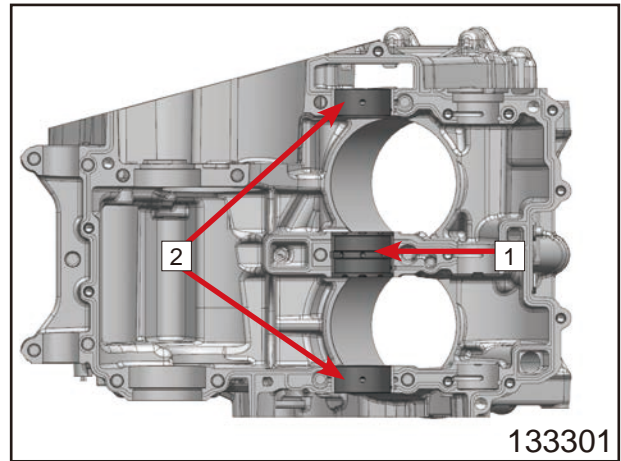

Position crankshaft in the upper section of the engine case.

Insert plastigauge clearance gauge (3) 90° offset to the bearing joint.

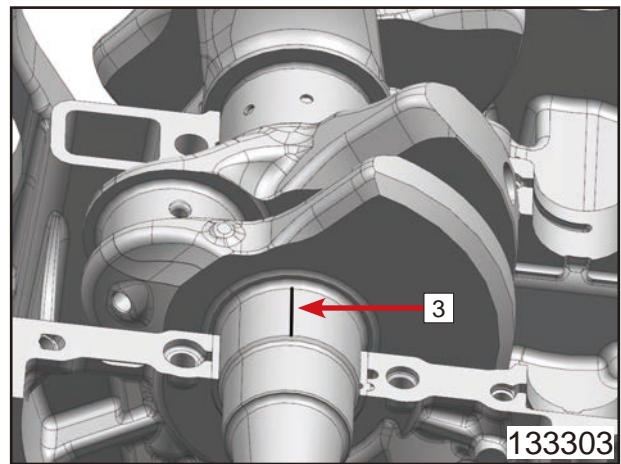

Mount lower engine case.

mount screws with washers and tighten in the order (4) to (9).

**guideline:**

Screw,engine case	M8x90	25N•m(18.4lbf•ft)
		Screw support greased

**NOTE**

Do not twist crankshaft.

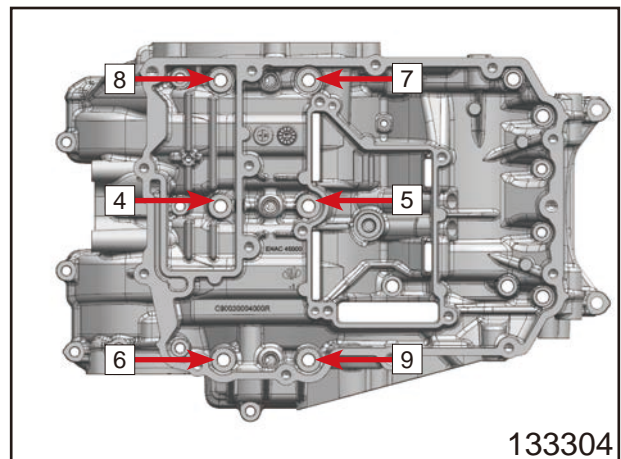

© CFMOTO Powersports, Inc. This manual is subject to all applicable copyright laws. Reproduction or duplication in any form, whole or in part, is strictly prohibited.

# CFMOTO

Remove lower section of the engine case again. Compare plastigauge clearance gauge with the data on the packaging. Guideline :

Crankshaft bearing	
New condition	0.030mm~0.060mm
Wear limit	0.080mm

**NOTE**

The width of the plastigauge clearance gauge indicates the bearing play.

Clean the part.

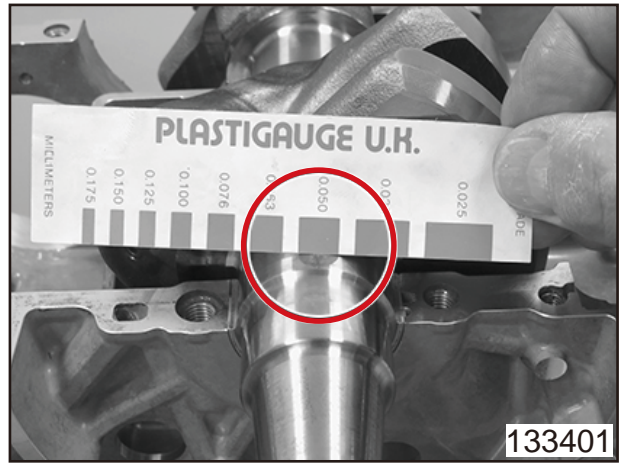

133401

### 13.4.2 Changing the Main Bearing Shells

Remove bearing shells (1) of the balancer shaft from the upper section of the engine case.

Remove bearing shells (2) and (3) of the crankshaft from the upper section of the engine case.

Clean seat of the bearing shells.

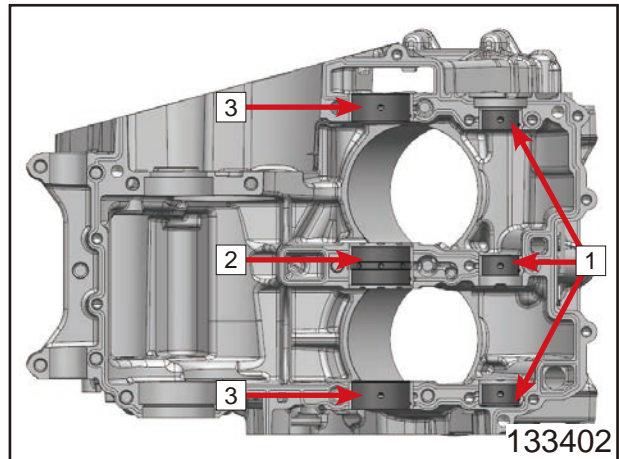

133402

Remove bearing shells (1) of the balancer shaft from the lower section of the engine case.

Remove bearing shells (2) and (3) of the crankshaft from the lower section of the engine case.

Clean seat of the bearing shells.

Select the main bearing shells.

Mount new bearing shells (2) and (3) in the lower section of the engine case.

Mount new bearing shells (1) in the lower section of the engine case

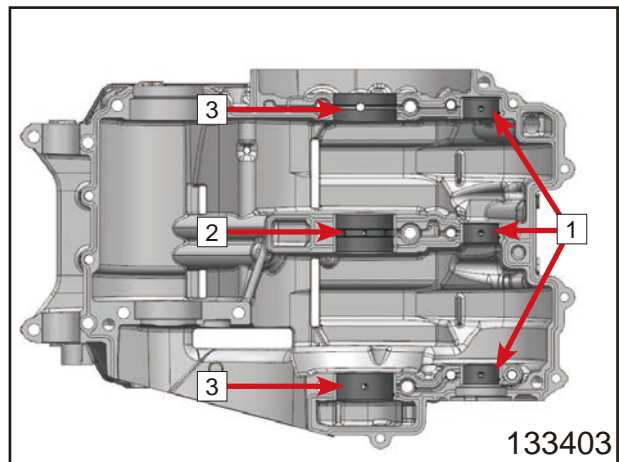

133403

Mount new bearing shells (2) and (3) in the upper section of the engine case.

Mount new bearing shells and (1) in the upper section of the engine case.

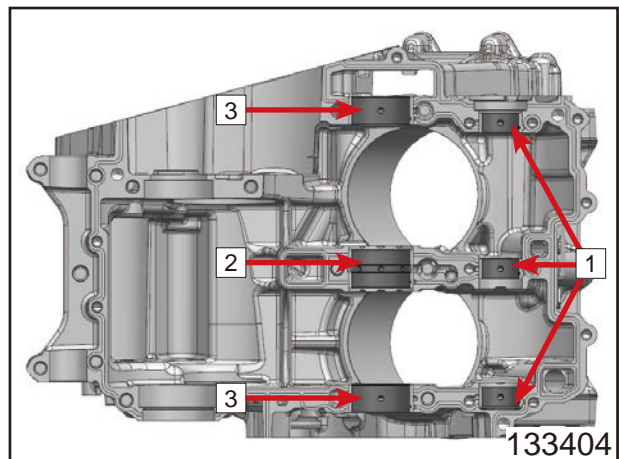

133404

© CFMOTO Powersports, Inc. This manual is subject to all applicable copyright laws. Reproduction or duplication in any form, whole or in part, is strictly prohibited.

## 13.4.3 Checking the Balancer Shaft

Clean all parts well.

Check the pivot points of the balancer shaft for damage and wear.

If there is damage or wear:

Change the balancer shaft.

Check the bearing shells of the balancer shaft for damage, abrasion and wear.

If there is damage, abrasion or wear:

Change bearing shells.

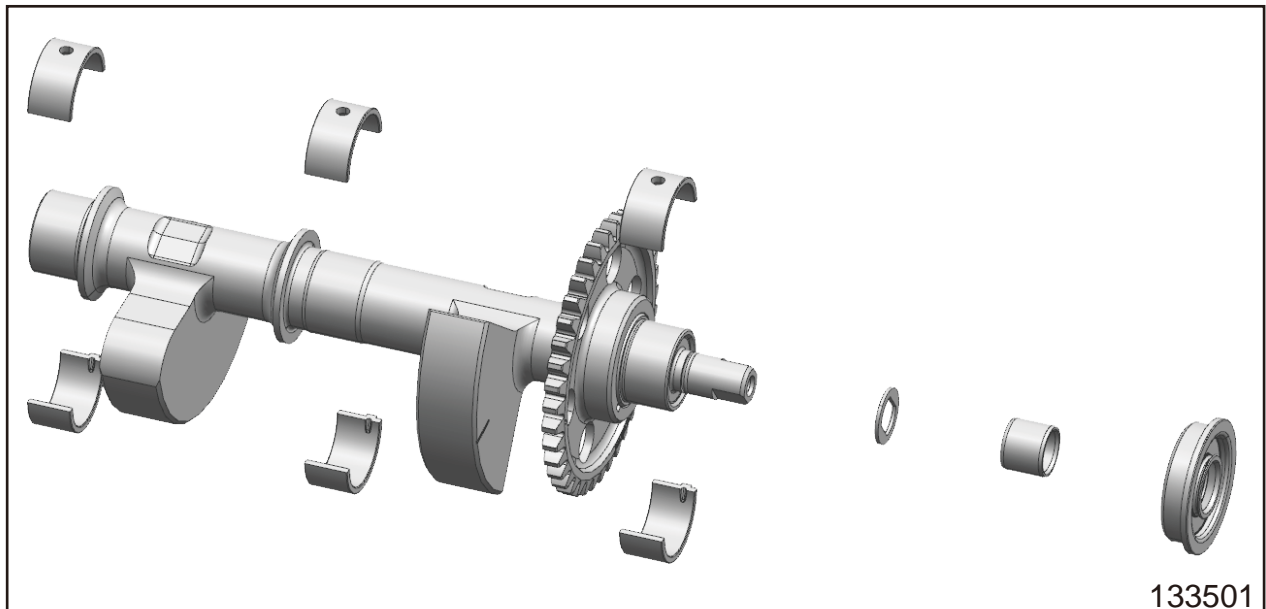

## 13.4.4 Working on the Upper Section of the Engine Case

Remove oil nozzles (1).

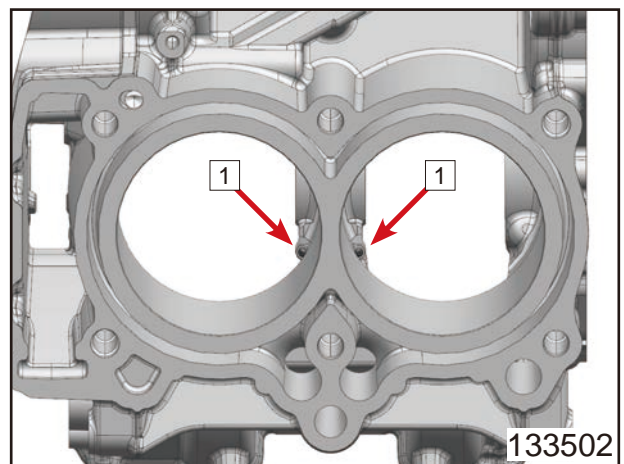

Remove radial shaft seal ring (2) of the shift shaft.

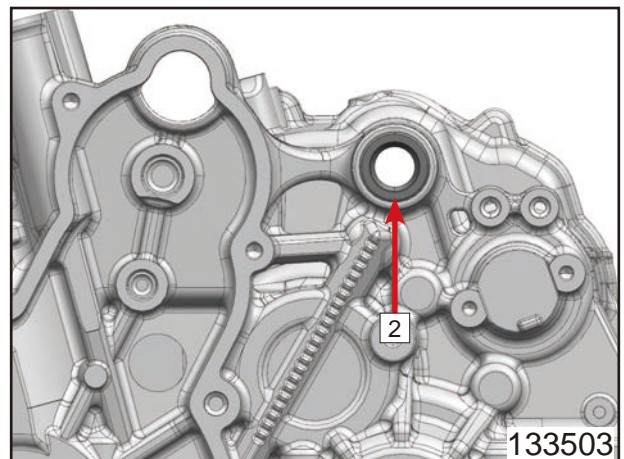

# CFMOTO

Remove any remnants of the sealing compound and clean the section of the engine case thoroughly.

Warm the section of the engine case in an oven.

## Guideline

130 °C (266°F)

Knock the section of the engine case with the right and left side against a level wooden board. This will cause the bearings to drop out of the bearing seats.

## NOTE

Any bearings that remain in the section of the engine case must be removed using a suitable tool.

A washer is located behind the bearing (7). Make sure that this washer is not damaged.

Warm the section of the engine case again.

## Guideline

130 °C (266°F)

Insert new cold bearings (3) and (4) in the bearing seat on the left side of the heated section of the engine case; if necessary, use a suitable pressing tool to push them all the way in and make them flush.

## NOTE

When pressing in, ensure that the section of the engine case lies flat in order to prevent damage.

Only press the bearings in using the outer bearing race; otherwise, the bearings will be damaged when they are pressed in.

Insert new cold bearings (5), (6) and (7) in the bearing seat on the right side of the heated section of the engine case; if necessary, use a suitable pressing tool to push them all the way in and make them flush.

## NOTE

Do not forget the washer under the bearing (7).

When pressing in, ensure that the section of the engine case lies flat in order to prevent damage.

Only press the bearings in using the outer bearing race; otherwise, the bearings will be damaged when they are pressed in.

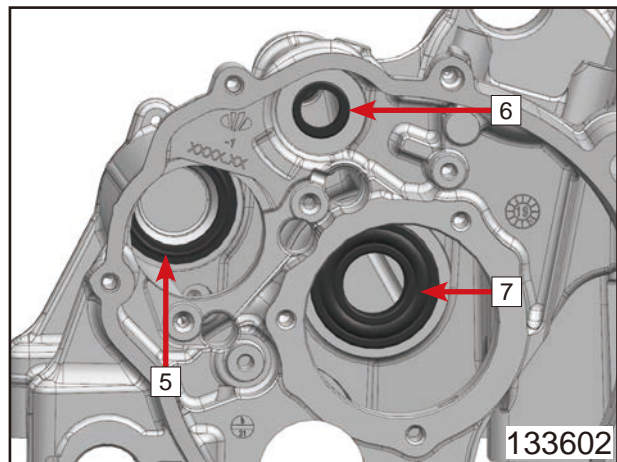
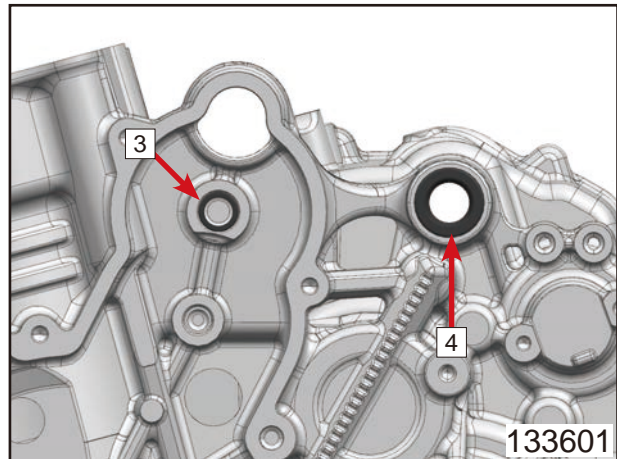

After the section of the engine case has cooled, check that the bearings are firmly seated.

**NOTE**

If the bearings are not firmly seated after cooling, it is likely that they will rotate in the engine case when warm. In this case, the engine case must be renewed.

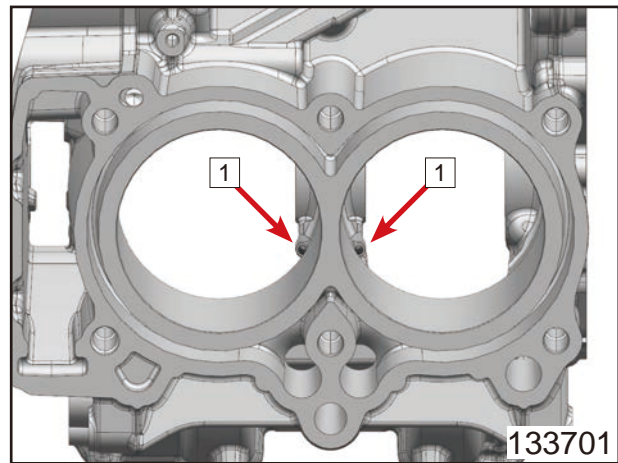

Press in new radial shaft seal ring (2) of the shift shaft from the outside to the inside with the open side facing in.

**NOTE**

The radial shaft seal ring must be flush on the outside.

Blow compressed air through all oil channels and oil nozzles, and check that they are clear.

Mount and tighten oil nozzles (1).

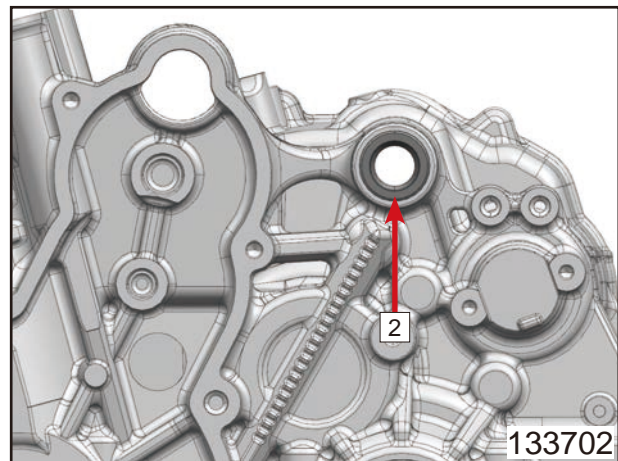

**Guideline**

Oil nozzle for piston cooling	M5	2 N•m (1.5 lbf •ft) 243 Thread locker
-------------------------------	----	--

### 13.4.5 Working on the Lower Section of the Engine Case

Remove oil nozzle (1).

Blow compressed air through all oil channels and oil nozzles, and check that they are clear.

Mount and tighten oil nozzle (1).

**Guideline**

Nozzle, engine vent	M5	2 N•m (1.5 lbf •ft) 243 Thread locker
---------------------	----	--

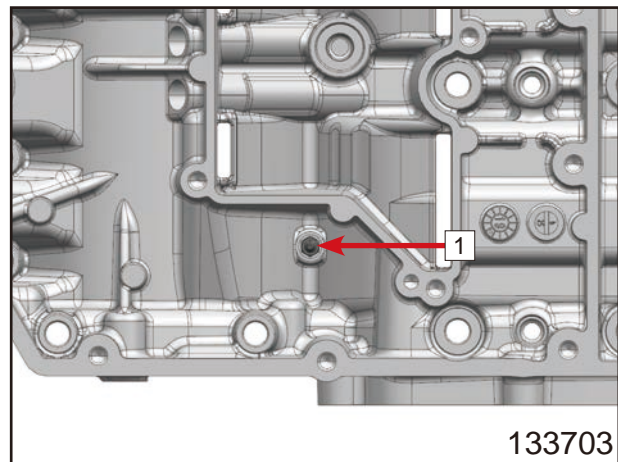

Swivel section of the engine case.

Check that dowels (2) are seated correctly.

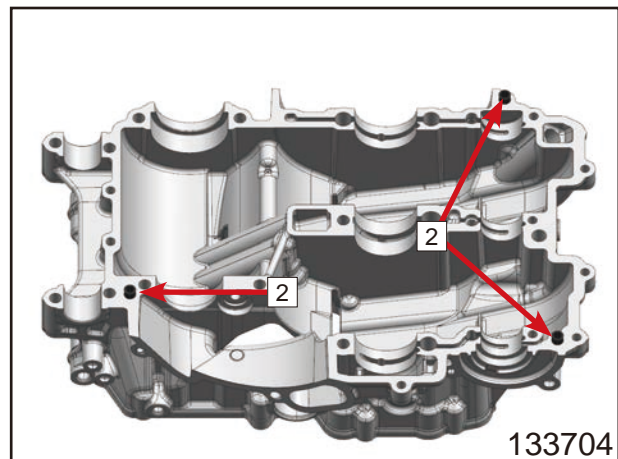

## 13.4.6 Selecting the Main Bearing Shells New Crankshaft

Select the new bearing shells according to color coding (1).

NOTE
Color coding (2) refers to the conrod bearing.

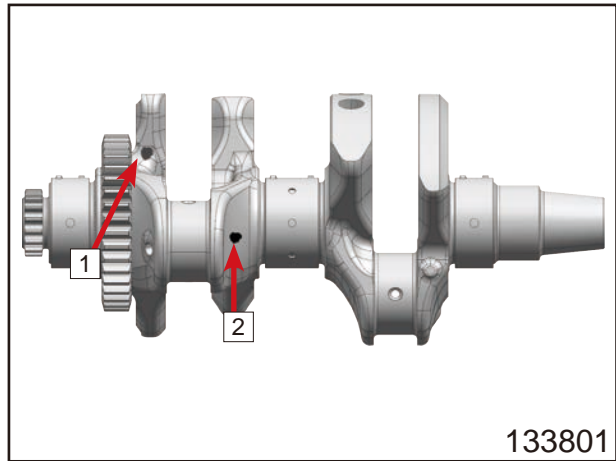

## Used Crankshaft

Measure all main bearing shells and select the new bearing shells accordingly.

Guideline

Crankshaft - main bearing diameter
Blue 37.985mm ~ 37.995 mm
Red 37.995mm ~ 38.005 mm

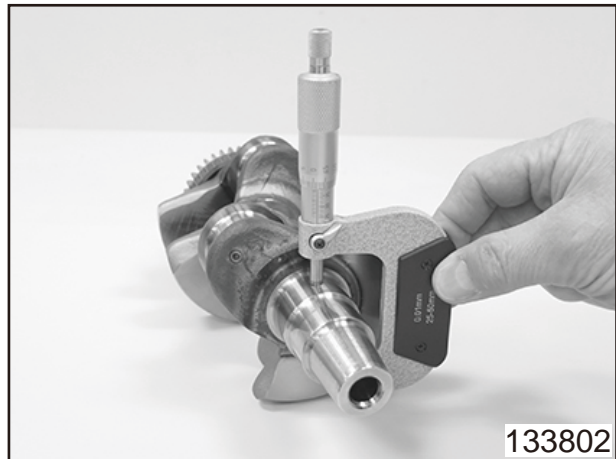

## 13.4.7 Installing the Primary Gear Wheel

Mount dowel pin (1) in the primary gear wheel.

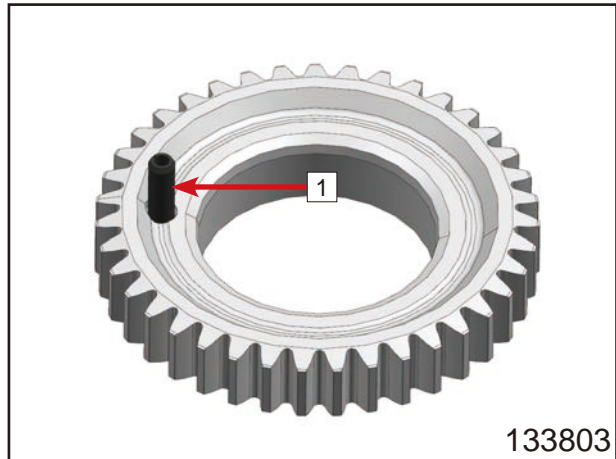

Position the crankshaft with a proper plate in the press.

Heat up primary gear wheel.

Guideline: 150 °C (302 °F)

Position primary gear wheel on the crankshaft.

Dowel pin (1) engages in hole (2).

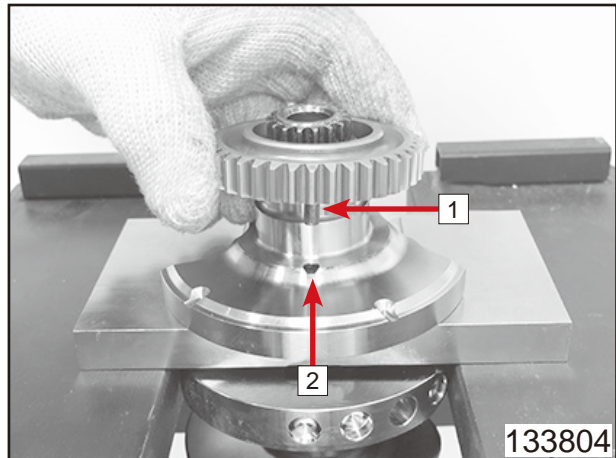

Mount primary gear wheel all the way with a proper pressing tool.

The marking is visible after mounting.

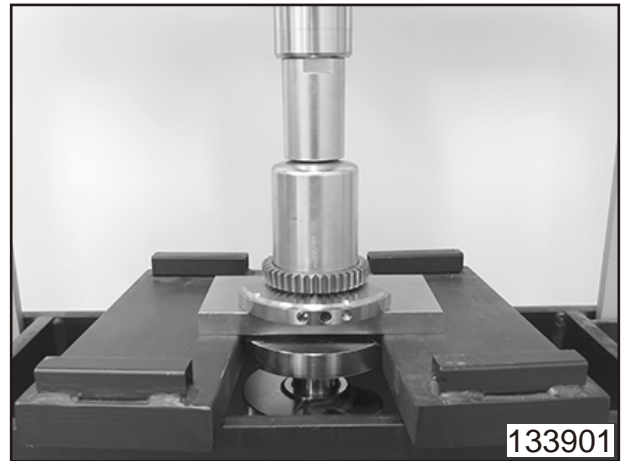

### 13.4.8 Radial Shaft Seal Ring of Water Pump, Changing Preparatory Work

Remove the water pump impeller.

#### Main Work

Remove radial shaft seal ring (1) of the water pump.

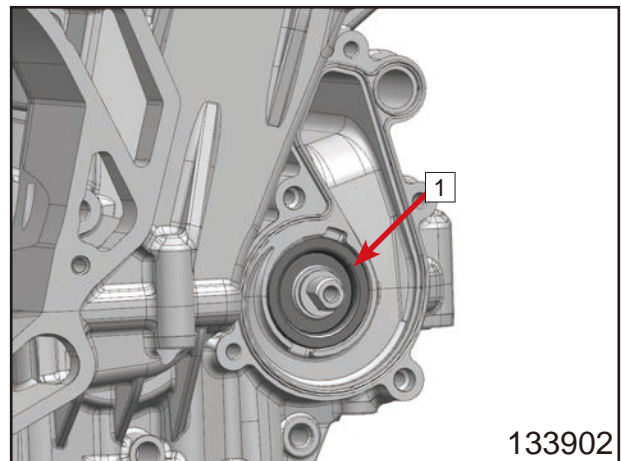

Remove water pump impeller (2).

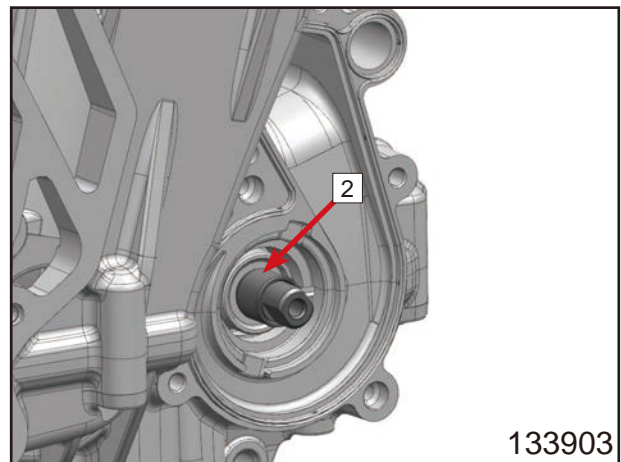

Remove O-ring (3).

Grease and mount the new O-ring (3).

Long-life grease

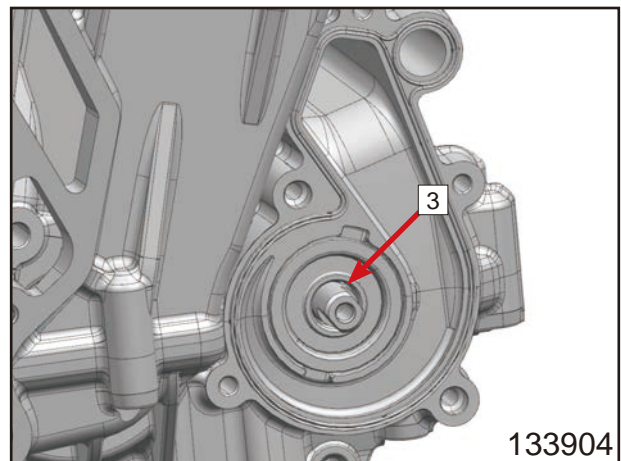

Grease and mount new radial shaft seal ring (1).

Long-life grease

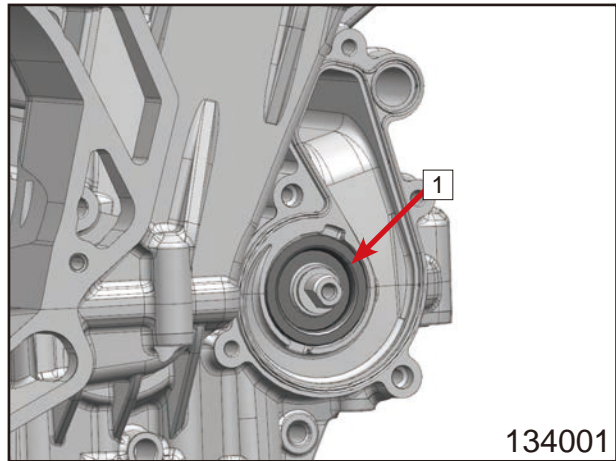

Mount the new water pump impeller (2).

### Finishing Work

Mount the water pump cover.

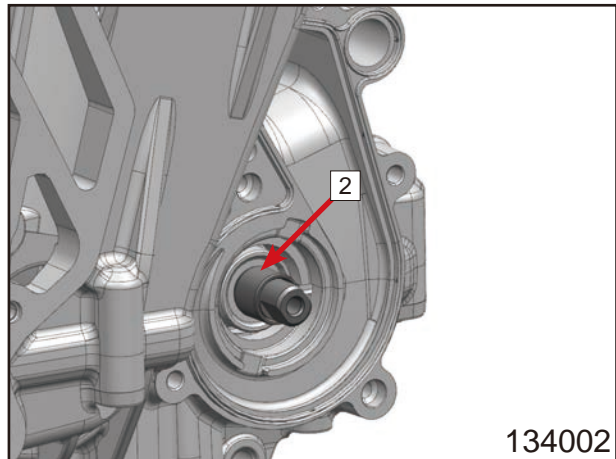

### 13.4.9 Checking the Radial Clearance of Lower Conrod Bearing

#### NOTE

Perform operations for both connecting rods.

Position the bearing shells. Insert Plastigauge clearance gauge (1) 90° offset to the bearing joint.

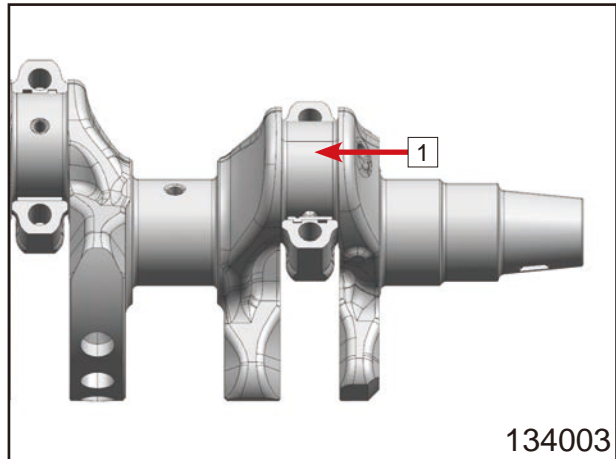

Position the conrod bearing cover. Mount and tighten the screws.

**Guideline:**

Screw, conrod bearing	M8	1st stage: 5 N•m (3.7 lbf•ft)
		2nd stage: 15 N•m (11.1 lbf•ft)
		3rd stage: 90°
Collar and thread oiled		

<b>NOTE</b>
Do not twist connecting rod.

Remove the conrod bearing cover again. Compare Plastigauge clearance gauge with the data on the packaging.

**Guideline:**

Connecting rod - radial clearance of lower conrod bearing
New condition: 0.030mm~0.060 mm
Wear limit: 0.080 mm

<b>NOTE</b>
The width of the Plastigauge clearance gauge indicates the bearing play.

Clean the parts.

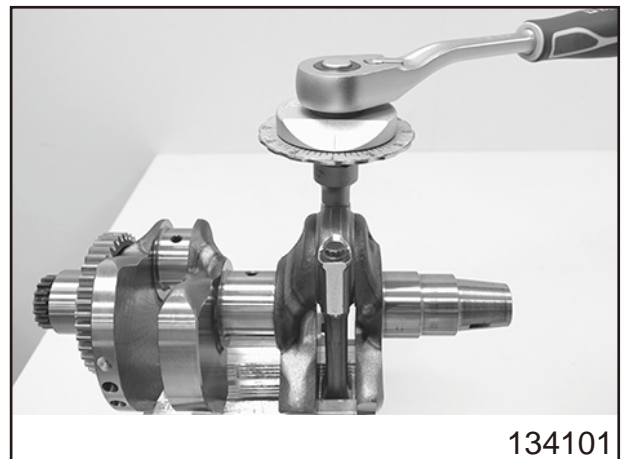

### 13.4.10 Changing the Conrod Bearing

<b>NOTE</b>
Perform operations for both connecting rods.

**Condition**

Connecting rod removed

**Main Work**

Take off bearing cover and remove bearing shells (1).

<b>NOTE</b>
The conrod bearing cover and connecting rod are jointly marked. Make sure that each conrod bearing cover is mounted on the same connecting rod.

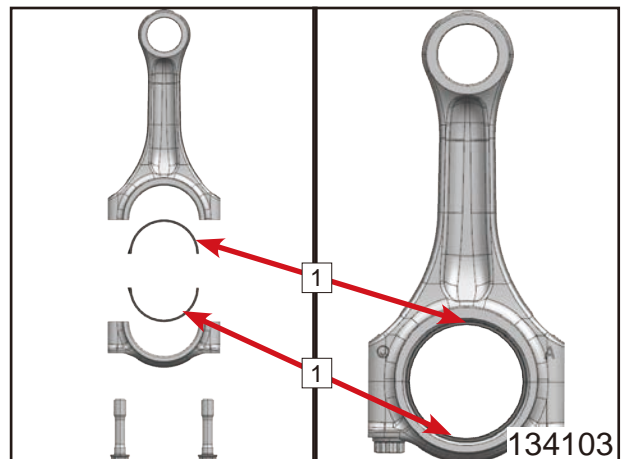

# CFMOTO

## New Crankshaft

Select the new bearing shells according to color coding (2).

NOTE
Color coding (3) refers to the crankshaft bearing.

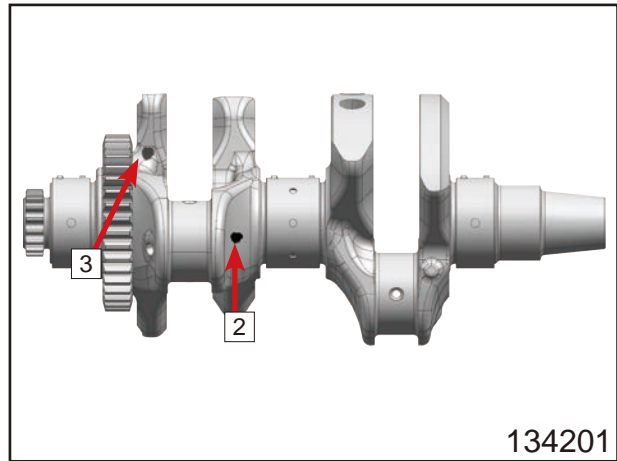

## Used Crankshaft

Measure the crank pin diameter and select the new bearing shells accordingly.

Guideline:

Crankshaft - crank pin diameter
Blue: 37.983 mm~ 37.993 mm
Red: 37.993 mm~ 38.003 mm

Check pivot points for damage and abrasion.

If damage or abrasion is discernible:  
Change the crankshaft.

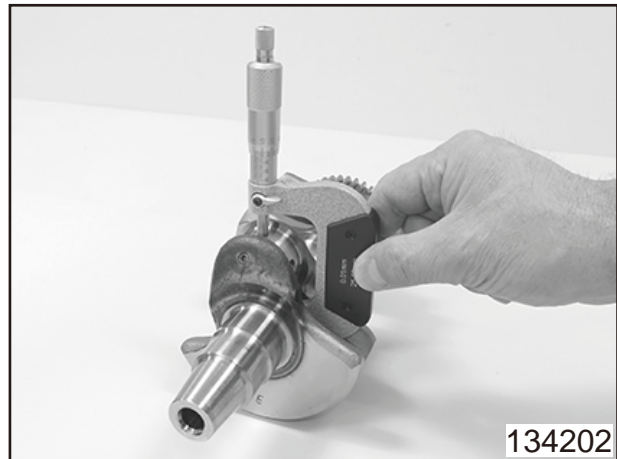

Mount new bearing shells (1) on conrod bearing cover and connecting rod.

NOTE
The conrod bearing cover and connecting rod are jointly marked. Make sure that each conrod bearing cover is mounted on the same connecting rod.

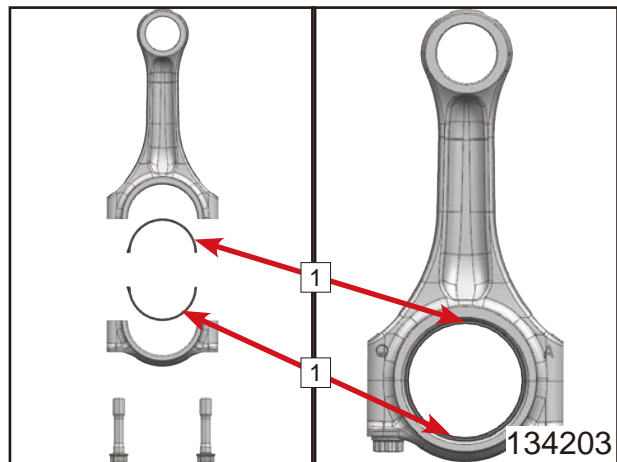

## Finishing Work

Check the radial clearance of lower conrod bearing.

## 13.4.11 Checking/Measuring the Cylinder

Check the O-ring of the chain adjuster for damage and wear.

If there is damage or wear: Change the O-ring.

Check the cylinder bearing surface for damage.

If the cylinder bearing surface is damaged: Change the cylinder and piston.

Measure the bore diameter at several locations on the (X)- and (Y)-axes using a micrometer to identify oval wear.

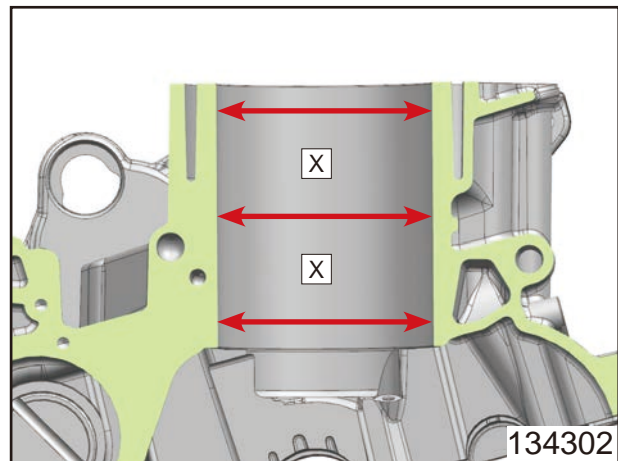
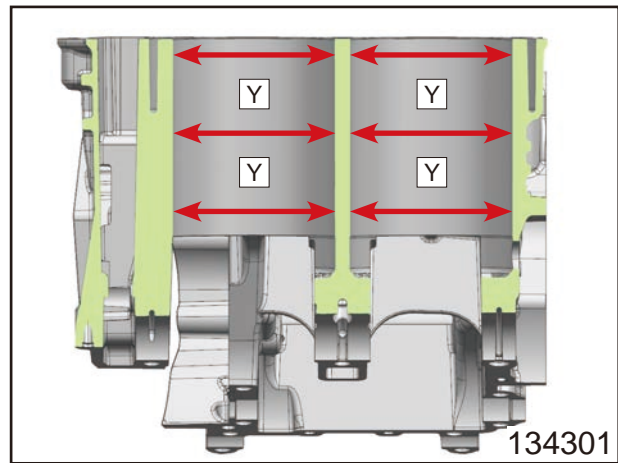

### Guideline:

Cylinder - bore diameter
Size: 88.000mm~88.012 mm

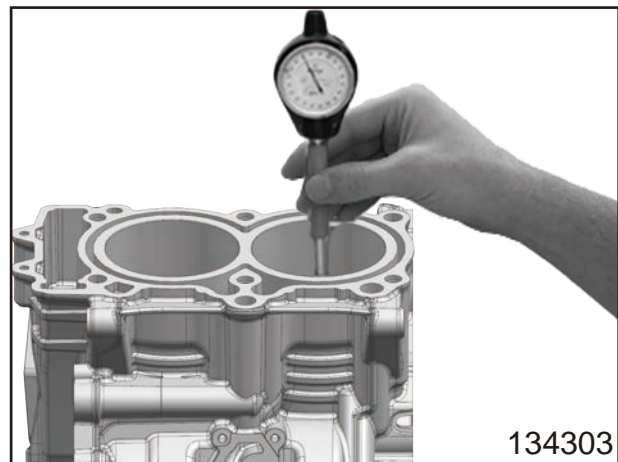

Using a straightedge and feeler gauge, check the sealing surface of the cylinder head for distortion.

Cylinder/cylinder head - sealing area distortion
$\leq 0.05$ mm

If the measured value does not meet specifications: Change engine case.

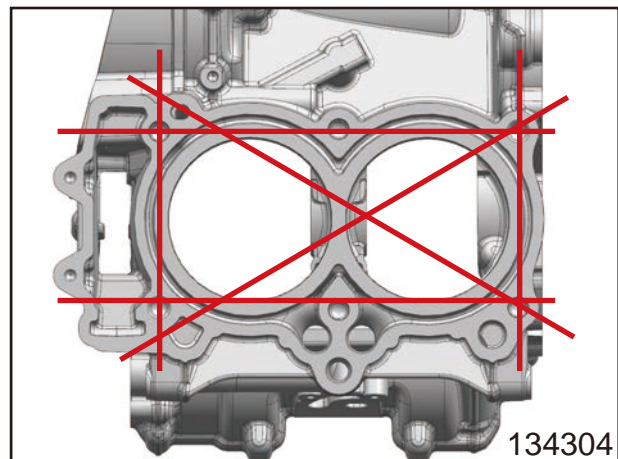

## 13.4.12 Checking/Measuring the Piston

Check the piston bearing surface for damage.

If the piston bearing surface is damaged: Replace the piston and, if necessary, the cylinder.

Check that the piston rings move easily in the piston ring grooves.

If the piston ring is stiff: Clean the piston ring groove.

### NOTE

An old piston ring can be used to clean the piston ring groove.

Check the piston rings for damage.

If the piston ring is damaged: Change the piston ring.

### NOTE

Mount the piston ring with the marking facing upward.

Use a feeler gauge to measure clearance (A) of the piston rings in the piston ring groove.

### Guideline

Piston ring - groove clearance
First ring (rectangular ring) ≤ 0.08 mm (≤ 0.0031 in)
Second ring (lower compression ring) ≤ 0.08 mm (≤ 0.0031 in)
Oil scraper ring ≤ 0.06 mm (≤ 0.0024 in)

If clearance (A) is larger than the specified value:

Change the piston and piston rings.

Check/measure the cylinder.

Check piston pin for discoloration, signs of wear or flaking of the coating.

If the piston pin exhibits significant discoloration/signs of wear, or the coating is flaking: Change the piston pin.

Place the piston pin in the connecting rod and check the seating for play.

If the piston pin seating has excessive play:

Change the connecting rod and piston pin.

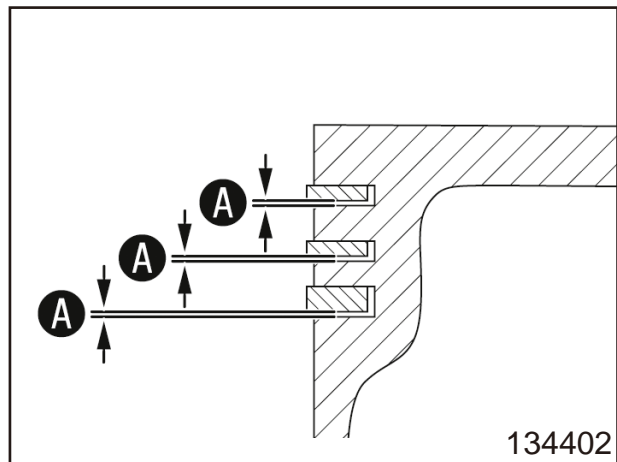

Measure the piston at the piston skirt, at right angles to the piston pin, at a distance (B).

Guideline

Piston - diameter
Size 87.920mm~ 87.980 mm
Distance (B) 6 mm (0.24 in)

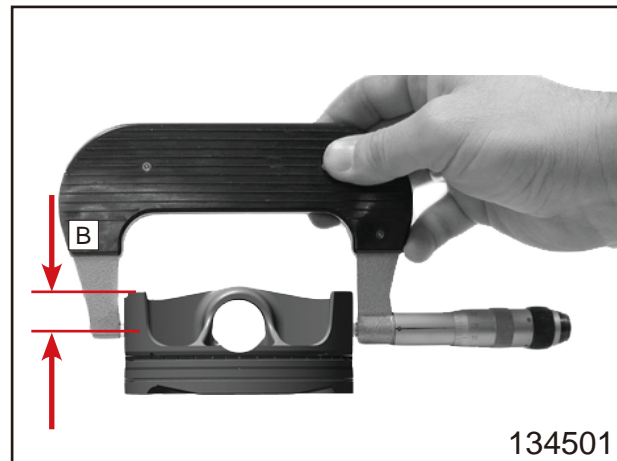

### 13.4.13 Checking the Piston Ring End Gap

Remove the piston ring from the piston.

Place the piston ring in the cylinder and align with the piston.

Guideline

Below the upper edge of the cylinder 10 mm
---

Measure end gap (A) with a feeler gauge.

Guideline

Piston ring end gap
Compression rings: $\leq 0.80$ mm
Oil scraper ring: $\leq 1.00$ mm

If the end gap is greater than the specified value: Check/measure the cylinder.

If cylinder wear lies within the specified tolerance: Change the piston ring.

Mount the piston ring with the marking facing toward the piston head.

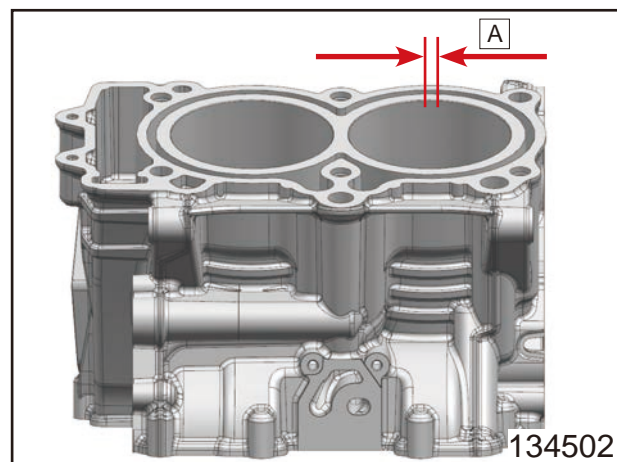

### 13.4.14 Determining the Piston/Cylinder Mounting Clearance

Check/measure the cylinder.

Check/measure the piston.

The smallest piston/cylinder mounting clearance is the result of the smallest cylinder bore diameter minus the largest piston diameter. The largest piston/cylinder mounting clearance is the result of the largest cylinder bore diameter minus the smallest piston diameter.

Guideline

Piston/cylinder - mounting clearance
New condition: 0.035mm~0.070 mm
Wear limit: 0.10 mm

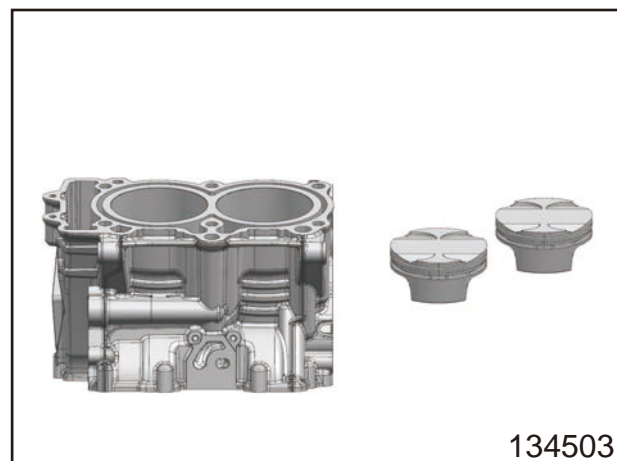

## 13.4.15 Removing the Oil Pumps

Remove lock ring (1) and washer (2).  
Take off oil pump gear wheel (3).

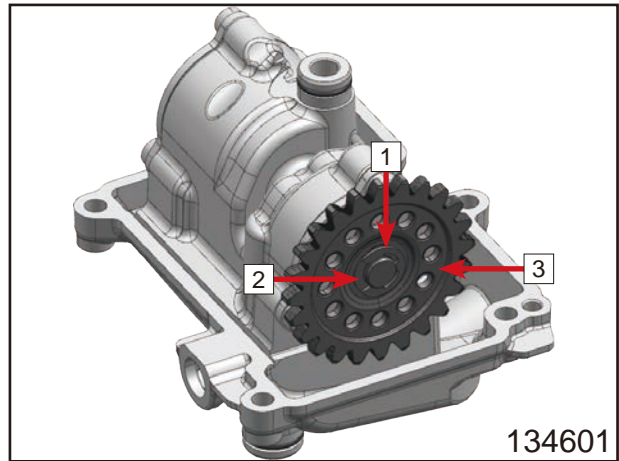

Remove pin (4) and washer (5).  
Remove screws (6).  
Take off the oil pump cover.

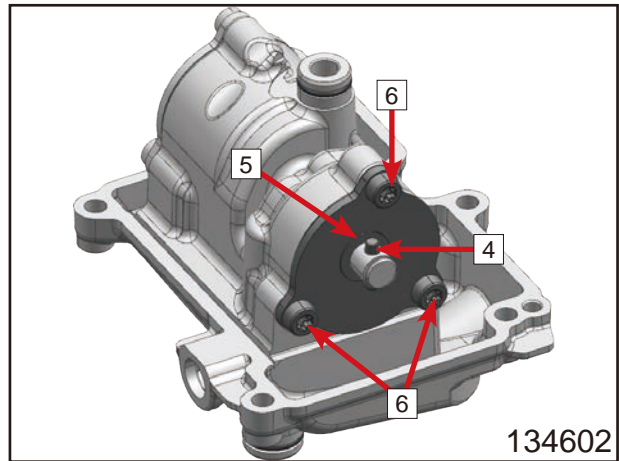

Remove external rotor (7).  
Remove internal rotor (8).

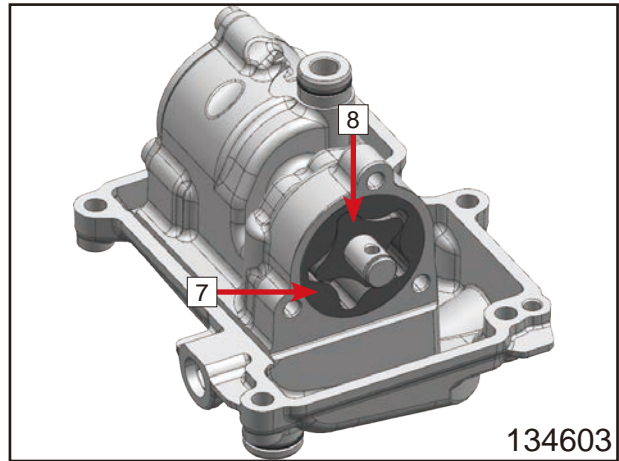

Remove pin (9).

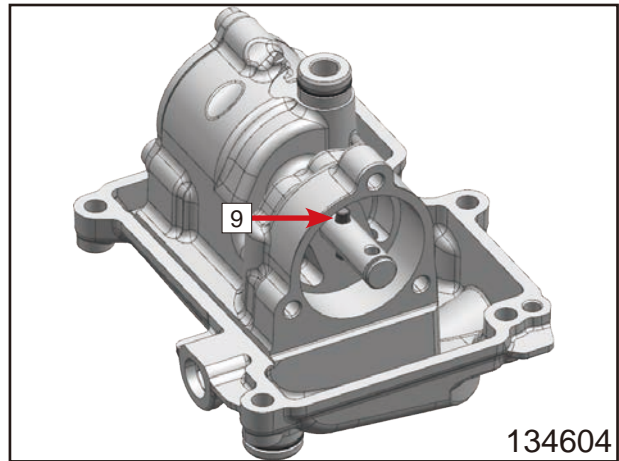

## 13 Engine

Remove screws (10).  
Take off the oil pump cover.

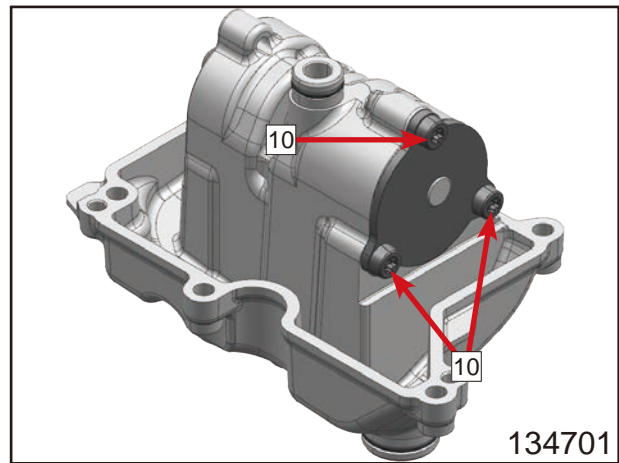

Remove pin (11) and oil pump shaft (12).

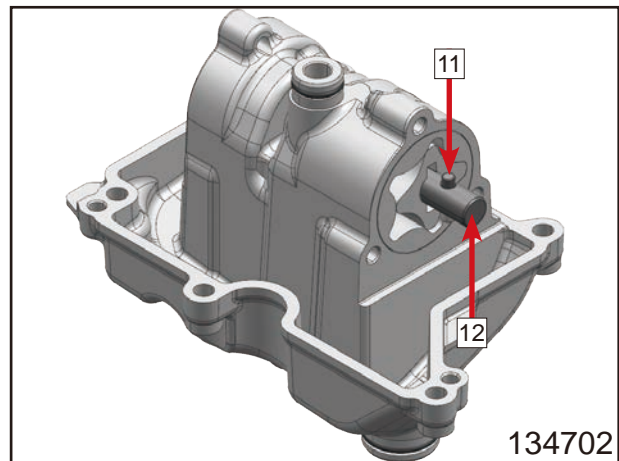

Remove external rotor (13) and internal rotor (14).

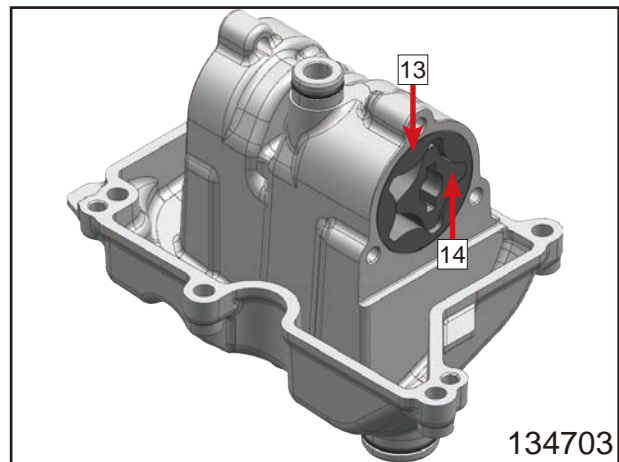

Remove O-rings (15).

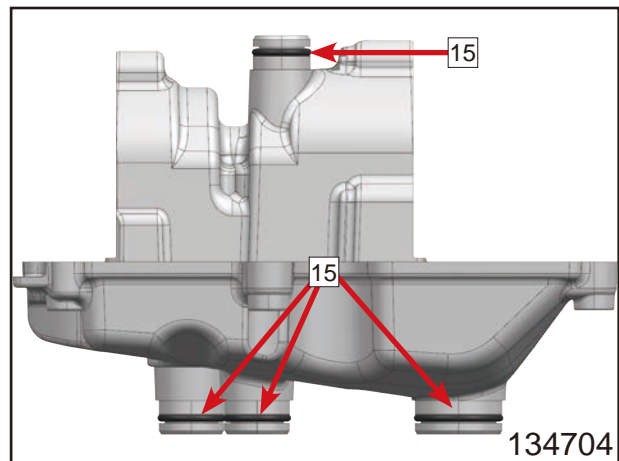

© CFMOTO Powersports, Inc. This manual is subject to all applicable copyright laws. Reproduction or duplication in any form, whole or in part, is strictly prohibited.

# CFMOTO

## 13.4.16 Checking the Oil Pumps for Wear

Use a feeler gauge to measure the play between the external rotor and oil pump housing as well as between the external rotor and internal rotor.

Oil pump
Play between external rotor and oil pump housing: $\leq 0.15$ mm
Clearance, external rotor/internal rotor: $\leq 0.20$ mm
Axial play: 0.03mm~0.08 mm

If the measured value does not meet specifications: Change the oil pump and, if necessary, the oil pump housing.

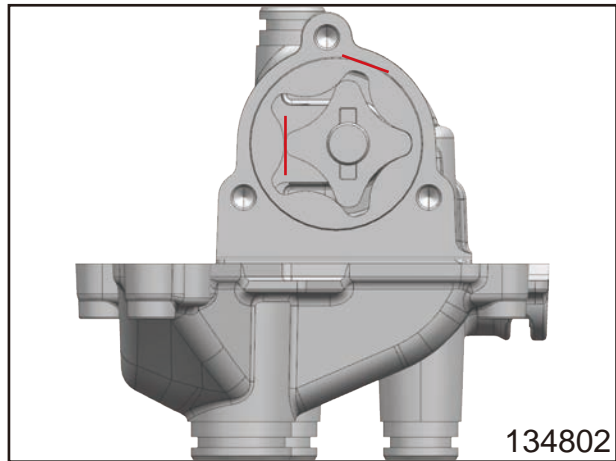
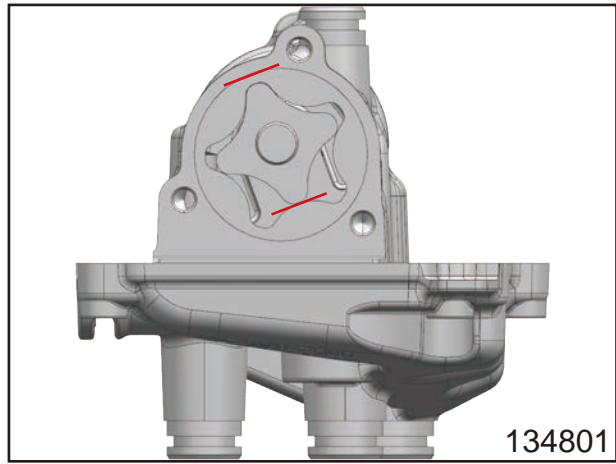

- Check the internal rotor and external rotor of oil pumps (1) for damage and wear.  
If there is damage or wear: Change the oil pumps.
- Check oil pump shaft (2) for damage and wear.  
If there is damage or wear: Change the oil pump shaft.
- Check both oil pump covers for damage and wear.  
If there is damage or wear: Change the oil pump cover.

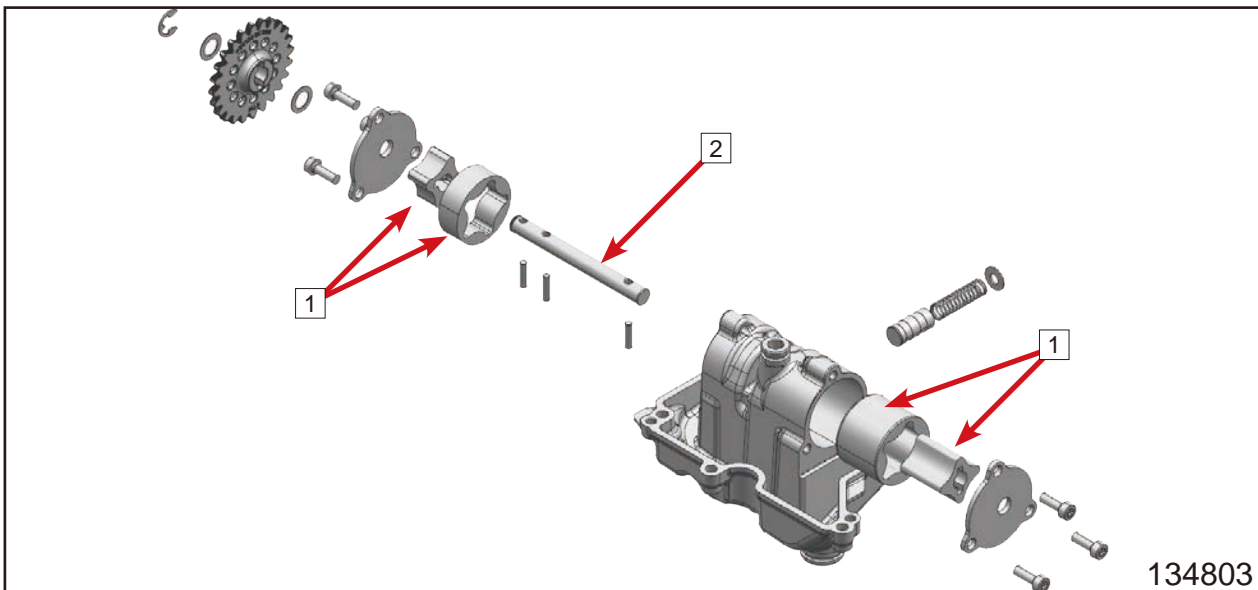

© CFMOTO Powersports, Inc. This manual is subject to all applicable copyright laws. Reproduction or duplication in any form, whole or in part, is strictly prohibited.

## 13.4.17 Checking the Oil Pressure Control Valve

Remove washer (1).

Remove spring (2).

Measure the length of spring (2).

Oil pressure regulator valve - minimum length spring: 40.0 mm

If the measured length is less than the specified value: Change the spring.

Check control piston (3) for damage and wear.

If there is damage or wear: Change the control piston.

Check the control piston for smooth operation in the oil pump housing.

If the control piston is stiff: Change the control piston or the oil pump housing.

Thoroughly oil control piston (3) and spring (2) and mount them.

Mount washer (1).

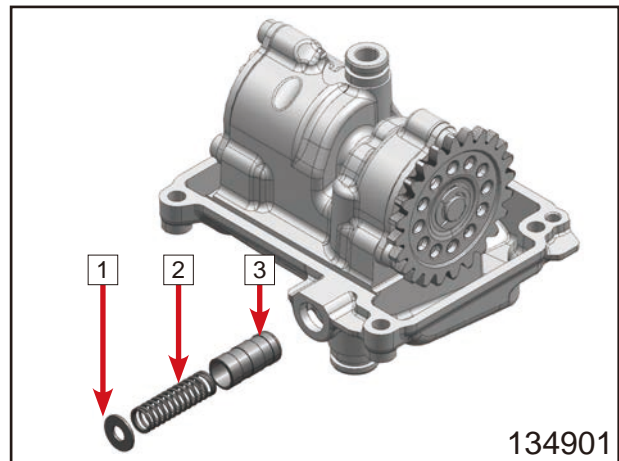

## 13.4.18 Installing the Oil Pumps

Mount and grease the new O-rings (1), (2) and (3).

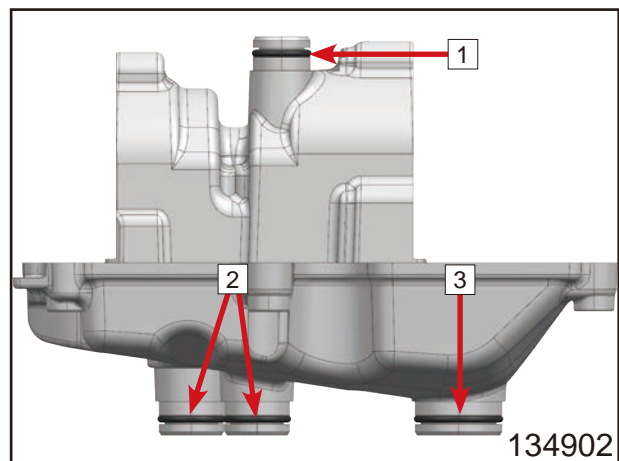

Mount external rotor (4) and internal rotor (5).

The rounded side of the external rotor must face the oil pump housing.

Oil the parts.

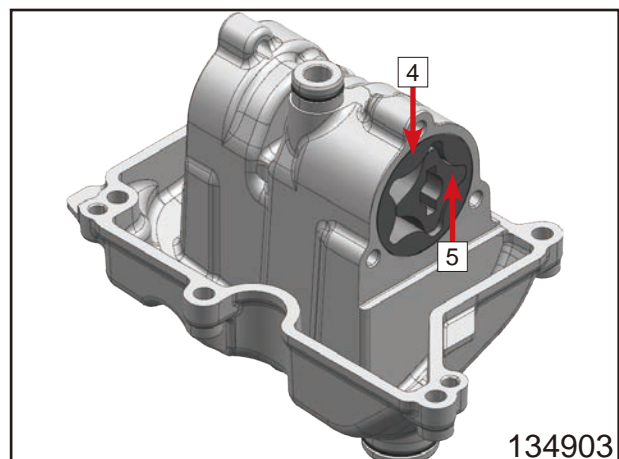

# CFMOTO

Mount oil pump shaft (6) with pin (7).

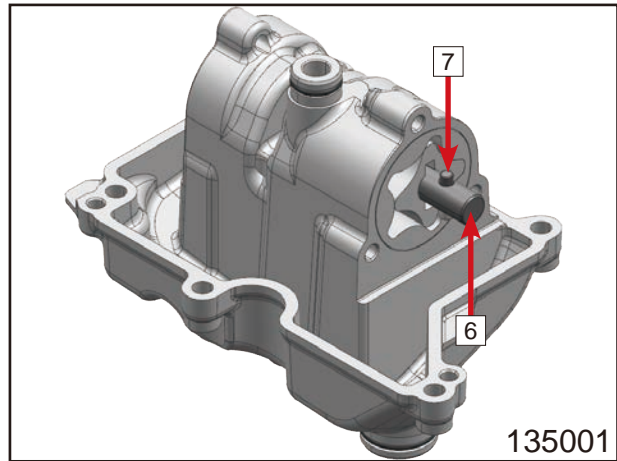

Position the oil pump cover.  
Mount and tighten screws (8).

### Guideline

Screw, oil pump cover	M6	10 N•m 243 Thread locker
-----------------------	----	-----------------------------

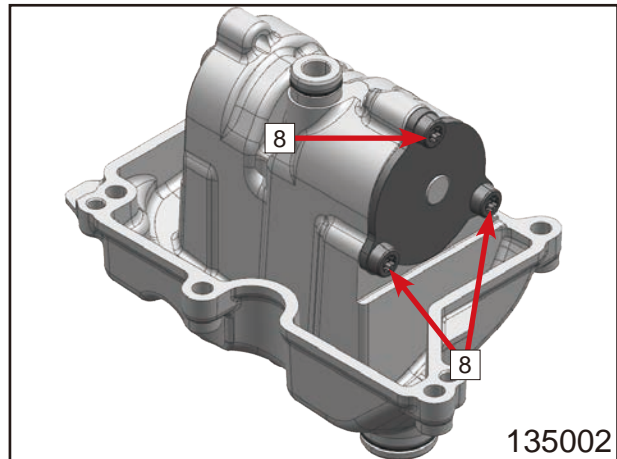

Mount pin (9).

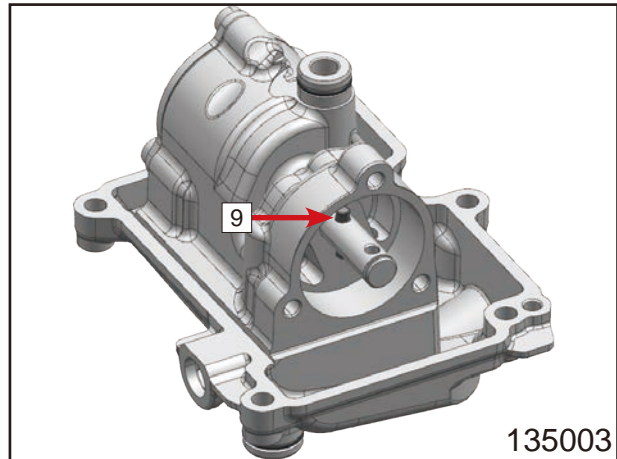

Mount external rotor (10) and internal rotor (11).

The rounded side of the external rotor must face the oil pump housing.

Oil the parts.

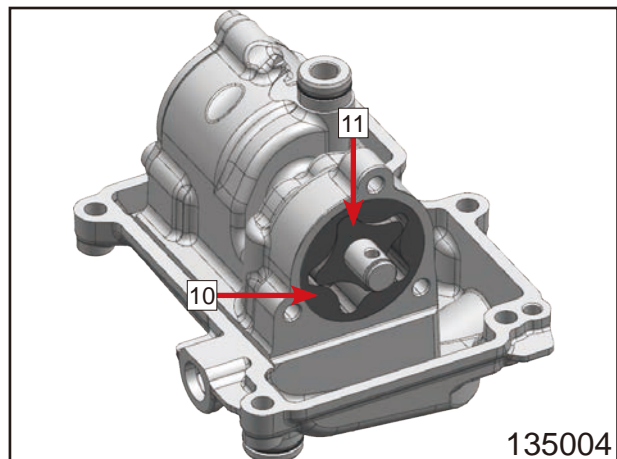

Position the oil pump cover.  
Mount and tighten screws (12).

### Guideline

Screw, oil pump cover	M6	10 N•m 243 Thread locker
-----------------------	----	-----------------------------

Mount washer (13).  
Mount pin (14).

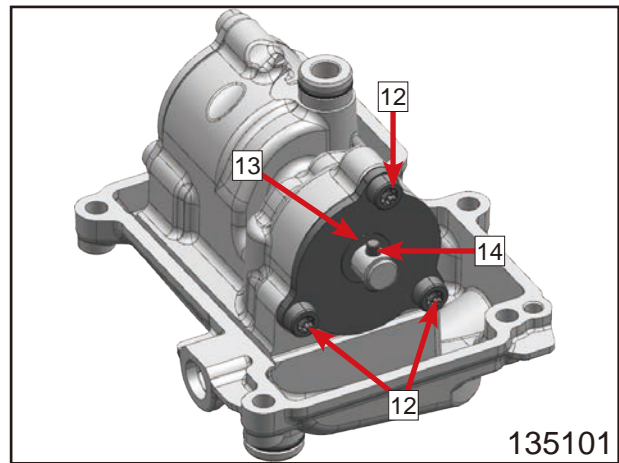

Mount oil pump gear wheel (15).  
Mount washer (16) and lock ring (17).

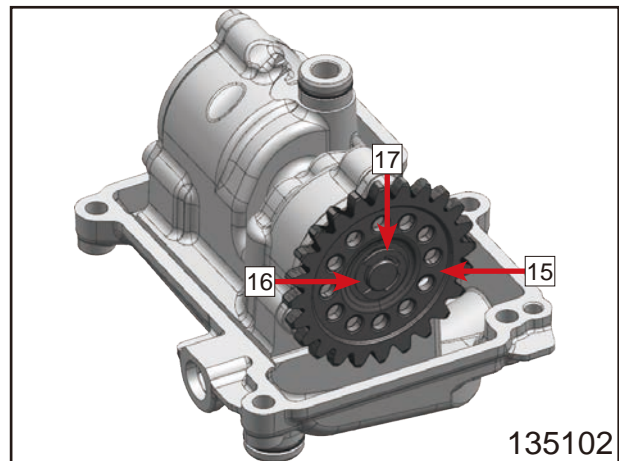

### 13.4.19 Preparing Timing Chain Tensioner for Installation

Fully compress the timing chain tensioner.

#### NOTE

This requires considerable force since the oil has to be pressed out.

Release the timing chain tensioner.

Without pressure, the timing chain tensioner expands fully.



# CFMOTO

Place two compensating disks or similar aids next to the piston of the timing chain tensioner. This should ensure that when pushed down, the piston does not fully withdraw.

## Guideline

Thickness of the compensating disks
2mm~ 2.5 mm

Release the timing chain tensioner.

The latching system locks and the piston stops moving.
--

End position of piston after latching
3 mm

## NOTE

This position is necessary for installation. If the timing chain tensioner is now pressed in once more (while it is installed) and then pulled out no more than halfway (preventing it from coming out fully), the latching system locks and the timing chain tensioner can no longer be compacted; this function is necessary to ensure sufficient tension of the timing chain, even at low oil pressure.



## 13.4.20 Checking the Timing Assembly

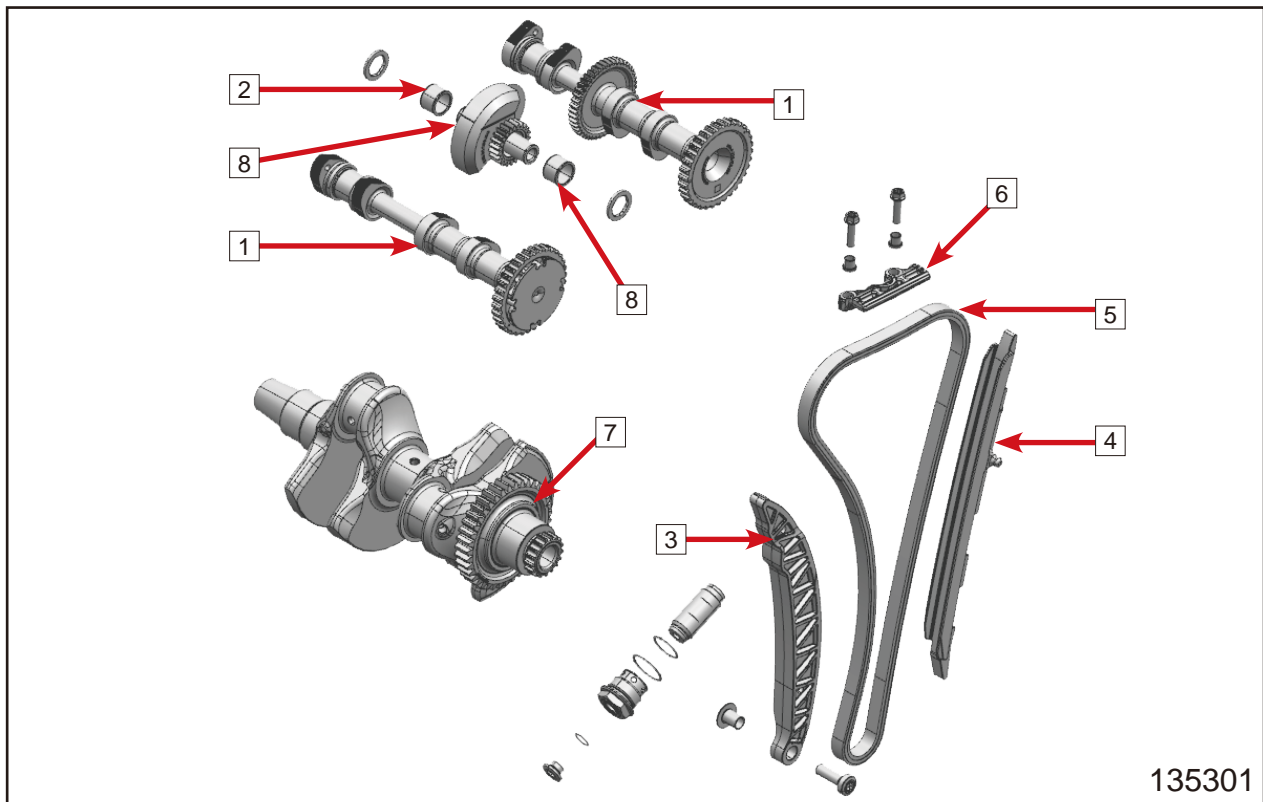

135301

Clean all parts well.

Check camshafts (1) for damage and wear.

If there is damage or wear: Change the camshafts.

Check balancer shaft (2) for damage and wear.

If there is damage or wear: Change the balancer shaft.

Check timing chain sprocket (3) for damage and wear.

If there is damage or wear: Change the timing chain sprocket.

Check guide rail (4) for damage and wear.

If there is damage or wear: Change the guide rail.

Check timing chain (5) for damage and wear.

If there is damage or wear: Change the timing chain.

Check the timing chain links for smooth operation. Let the timing chain hang down freely.

The chain links no longer align in a straight line: Change the timing chain.

Check guide rail (6) for damage and wear.

If there is damage or wear: Change the guide rail.

Check timing chain sprocket (7) for damage and wear.

If there is damage or wear: Change the crankshaft.

Check balancer shaft bearing (8) for damage and wear.

If there is damage or wear: Change the balancer bearing.

# CFMOTO

## 13.4.21 Working on the Camshaft Bearing Bridge

Remove O-rings (1).

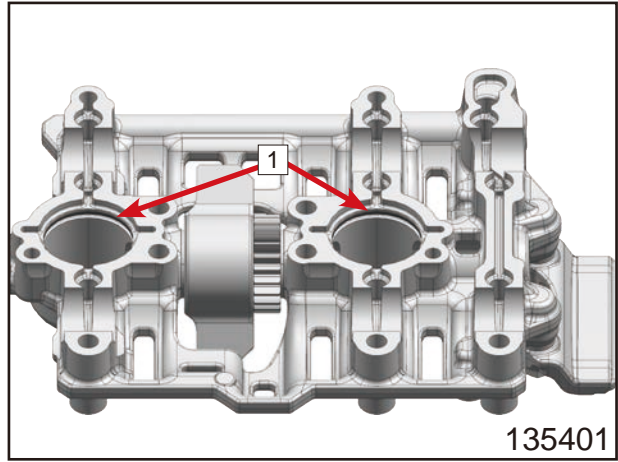

Remove screws (2).  
Take off guide rail (3).

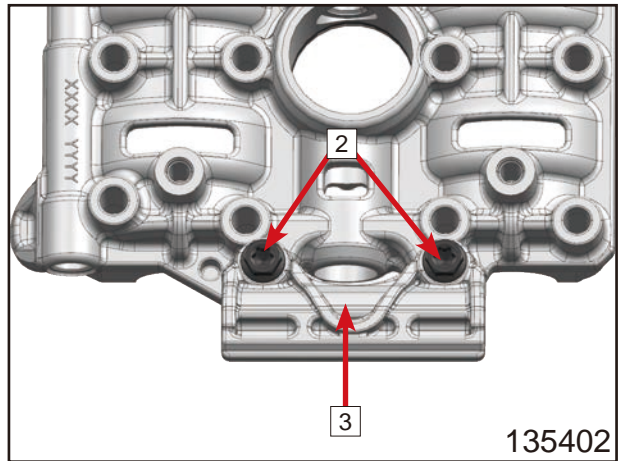

Pull out spindle (4) of the balancer shaft with appropriate screw M10.

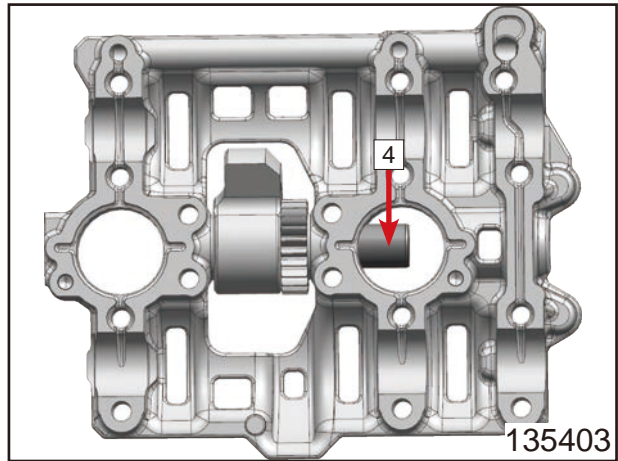

Remove balancer shaft with needle bearings (5) and washers (6).

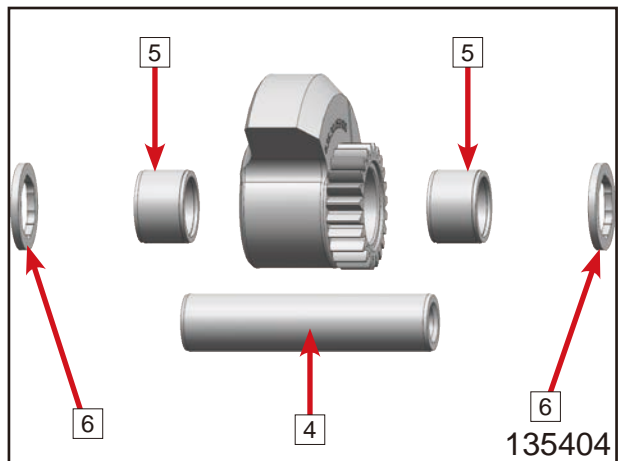

© CFMOTO Powersports, Inc. This manual is subject to all applicable copyright laws. Reproduction or duplication in any form, whole or in part, is strictly prohibited.

Mount new needle bearings (5) in the balancer shaft and oil.  
Position balancer shaft with washers (6) in the camshaft bearing bridge.

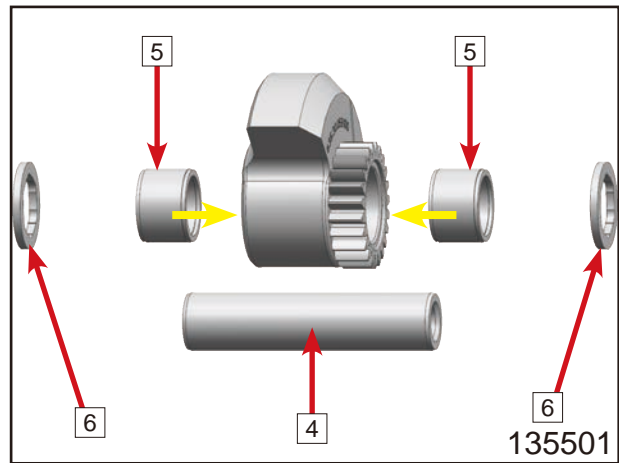

Mount spindle (4) of the balancer shaft in the center between the spark plug shafts.  
Remove screw M10.

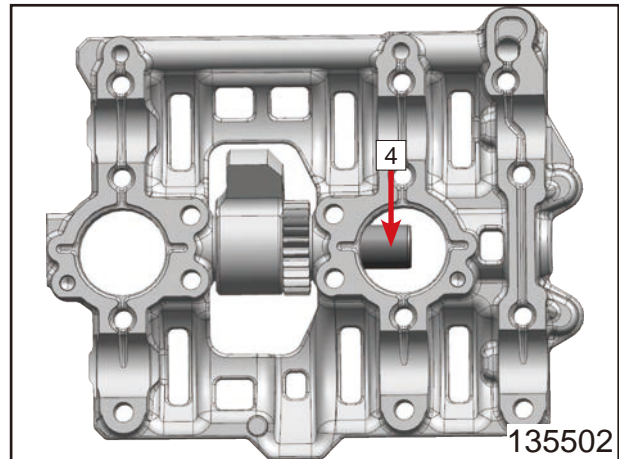

Position guide rail (3).  
Mount and tighten screws (2).  
Guideline

Screw, upper guide rail
M6
8 N•m
243 Thread locker

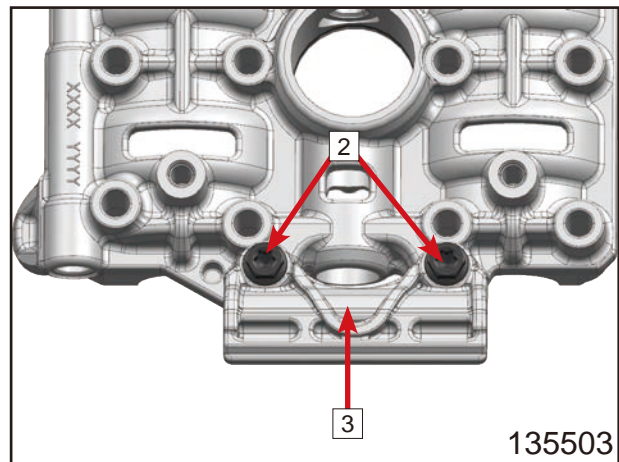

Mount and grease the new O-rings (1).

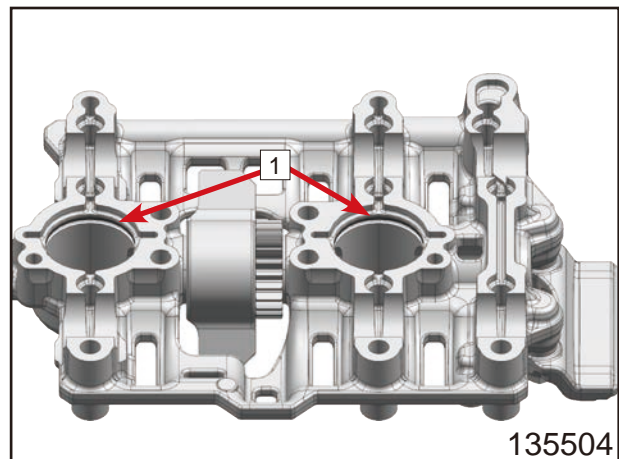

© CFMOTO Powersports, Inc. This manual is subject to all applicable copyright laws. Reproduction or duplication in any form, whole or in part, is strictly prohibited.

## 13.4.22 Working on the Cylinder Head

Remove screw plugs (1) with the O-rings.

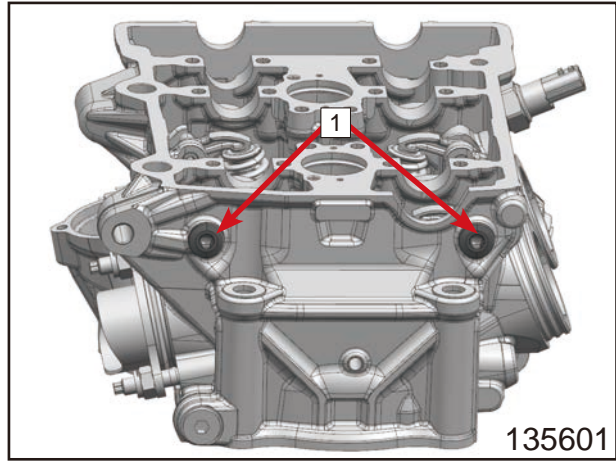

Remove screws (2).

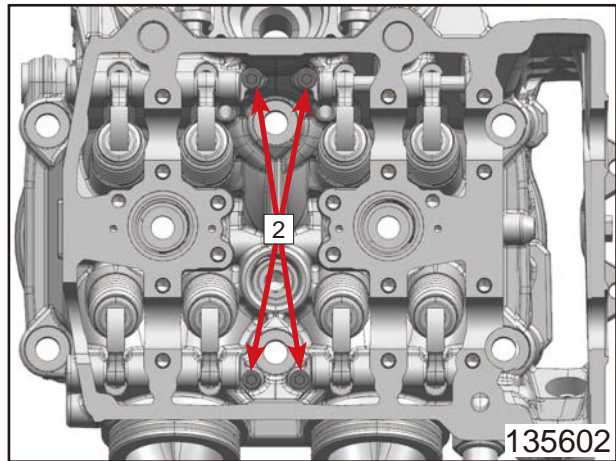

Mount appropriate screw M4 noto cam lever shaft.  
Remove cam lever shafts (3).

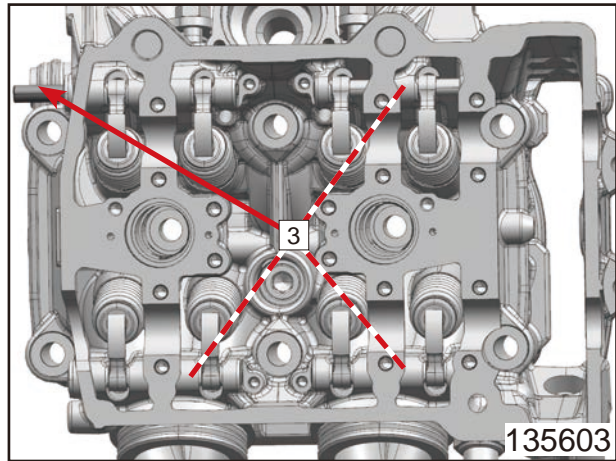

Take off cam lever (4).

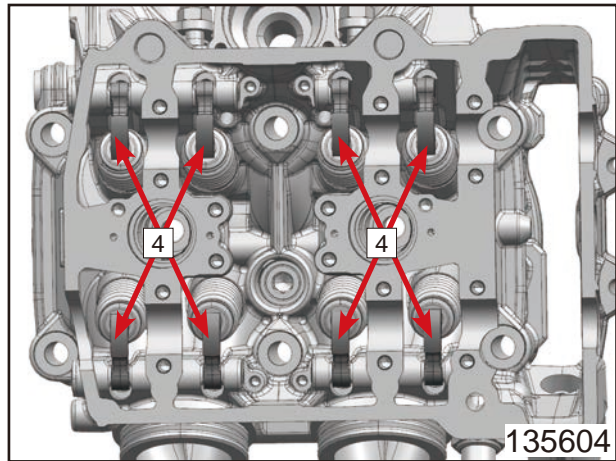

Remove shims (5) and label according to their normal built-in position.

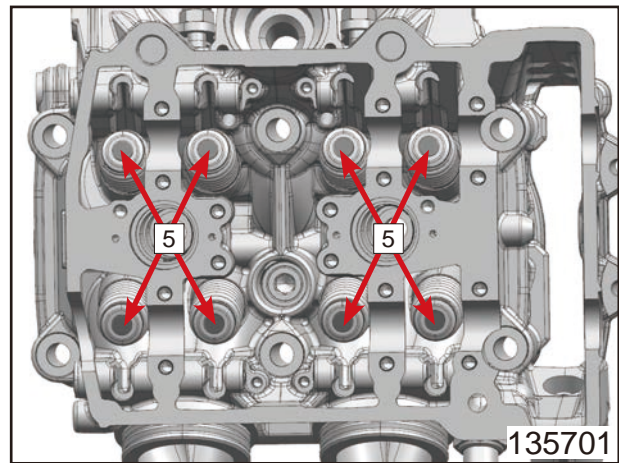

Remove oil pressure sensor (6) with O-ring.  
Remove coolant temperature sensor (7) with the O-ring.

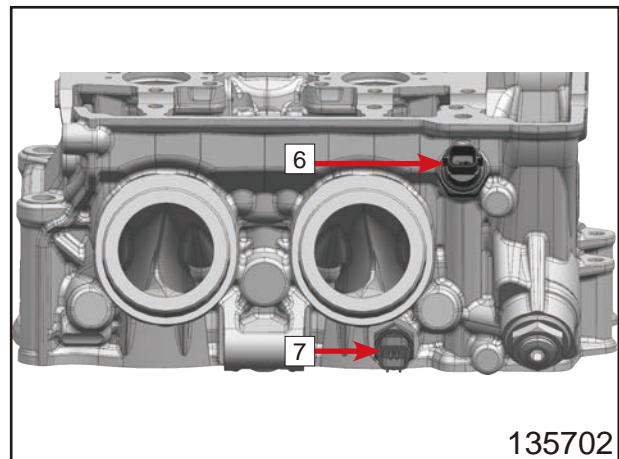

Tension valve spring with a valve spring compressing clamp (8).

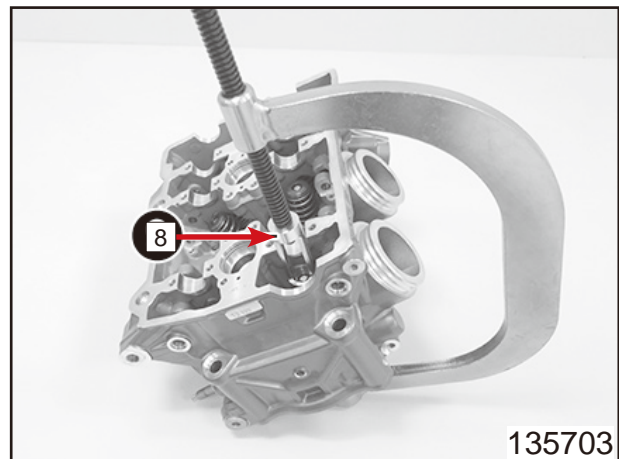

Remove valve collets (9) and release the valve spring.

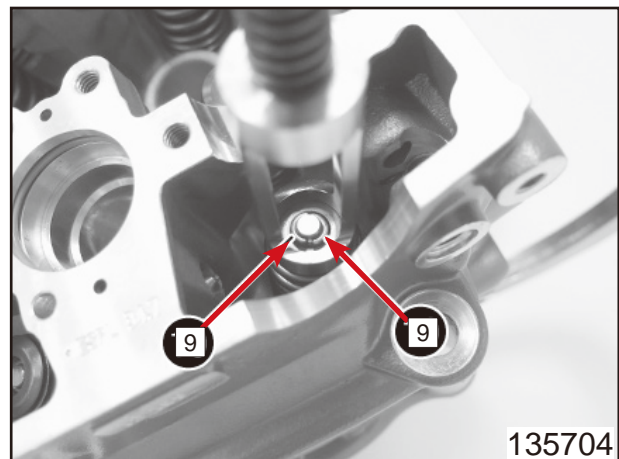

© CFMOTO Powersports, Inc. This manual is subject to all applicable copyright laws. Reproduction or duplication in any form, whole or in part, is strictly prohibited.

# CFMOTO

Remove valve spring retainers (10), valve springs, valve stem seals (11) and valve spring seats (12).

**NOTE**

Place the valves in a box according to their normal built-in position and label them.

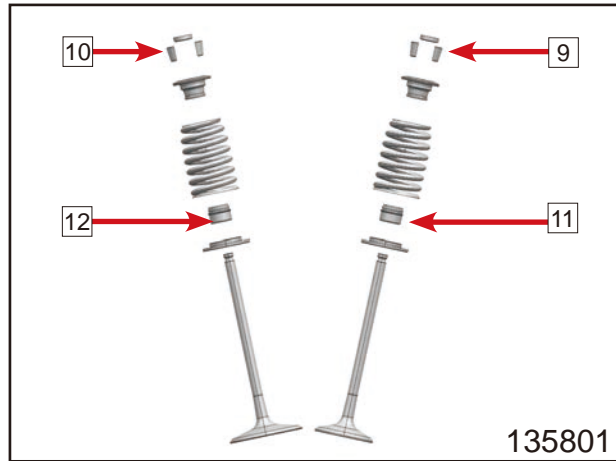

Remove O-rings (13).

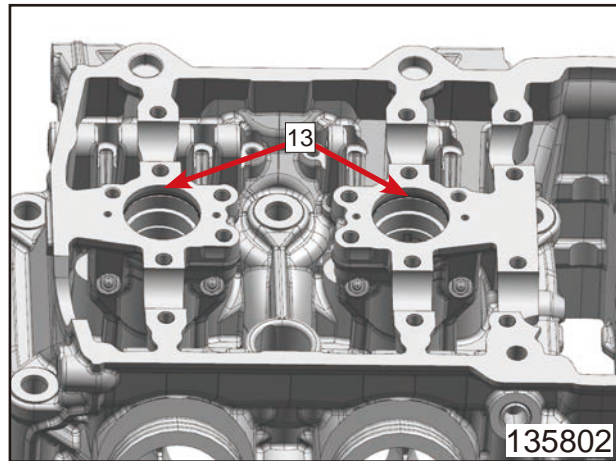

Remove oil nozzles (14).  
Remove oil screen (15) and clean it.  
Check the cylinder head.

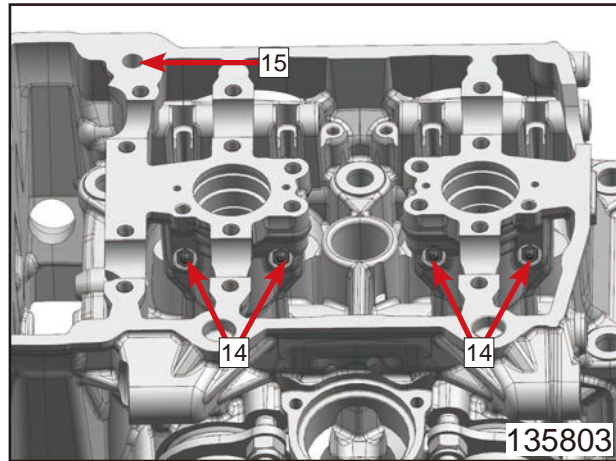

Mount oil screen (15).  
Mount oil nozzles (14).

**Guideline**

Oil nozzle in cylinder head
M5
2 N•m
243 Thread locker

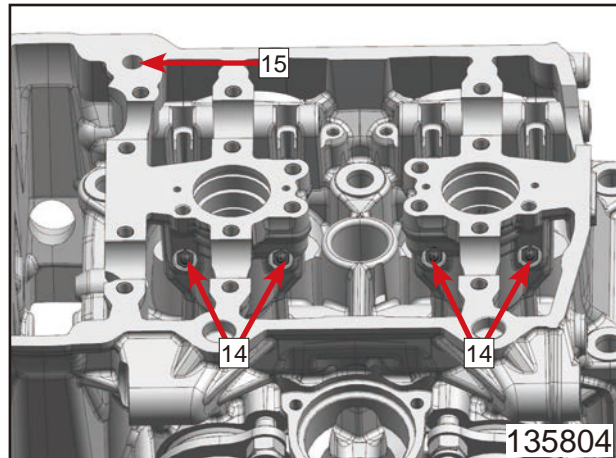

© CFMOTO Powersports, Inc. This manual is subject to all applicable copyright laws. Reproduction or duplication in any form, whole or in part, is strictly prohibited.

Mount and grease O-rings (13).

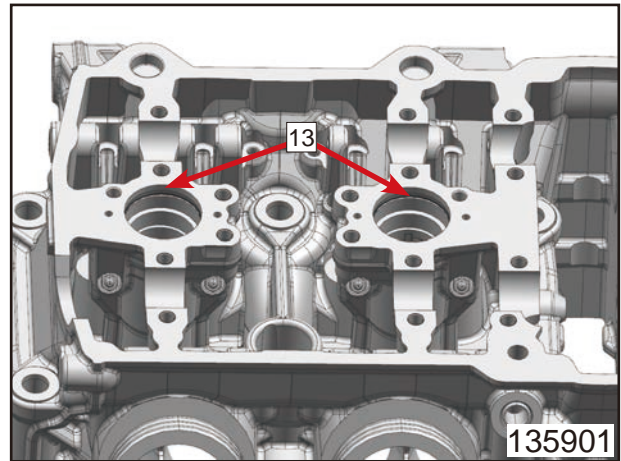

Mount valve spring seats (12) and new valve stem seals (11).  
Mount valve spring retainers (10) and valve springs.

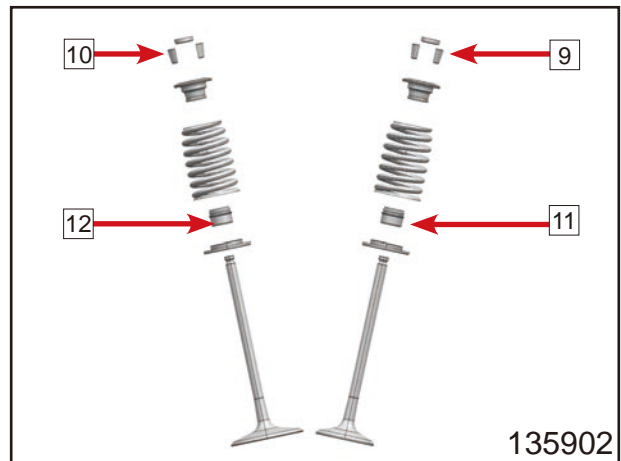

Tension valve spring with a valve spring compressing clamp (8).

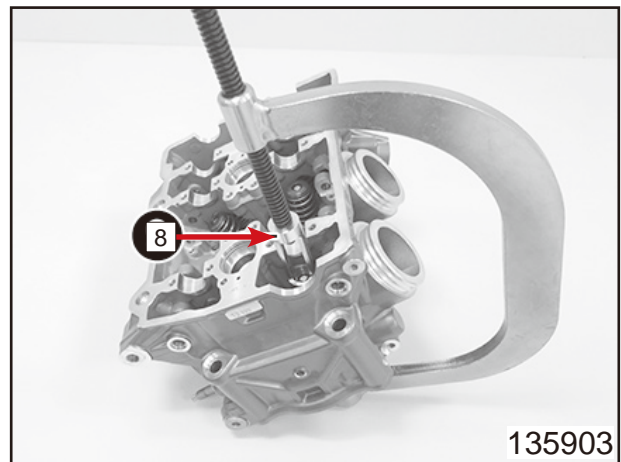

Mount valve collets (9). Release the tension on the valve spring.

NOTE
When mounting the valve collets, check they are seated properly, preferably use a little grease to secure the valve collets on the valve.

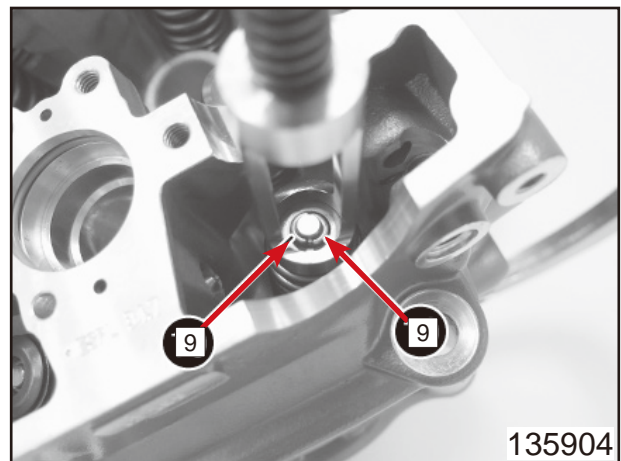

© CFMOTO Powersports, Inc. This manual is subject to all applicable copyright laws. Reproduction or duplication in any form, whole or in part, is strictly prohibited.

# CFMOTO

Mount coolant temperature sensor (7) with the new O-ring.

## Guideline

Coolant temperature sensor
M10×1.25
10 N•m

Mount oil pressure sensor (6) with new O-ring.

## Guideline

Oil pressure sensor
M10×1
10 N•m

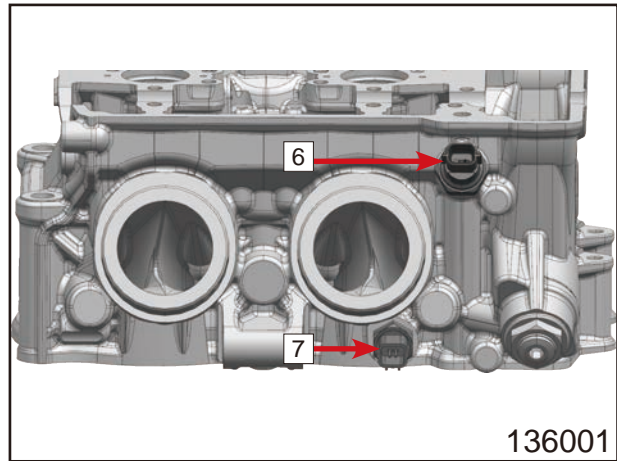

Place shims (5) into the valve spring retainer according to their normal built-in position.

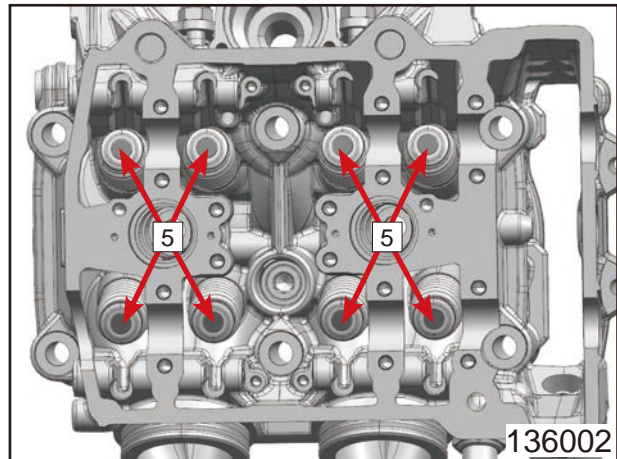

Position cam levers (4).

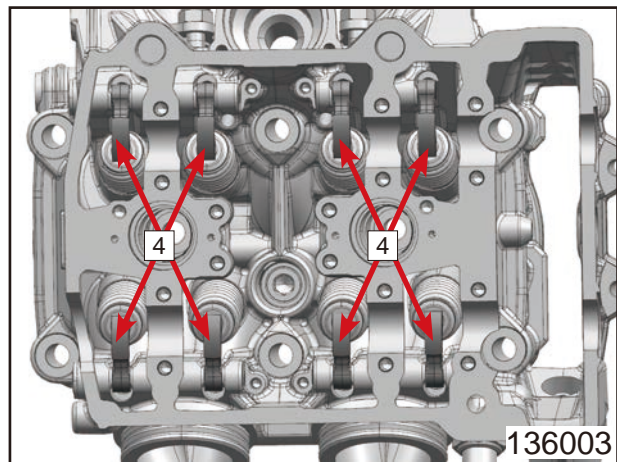

Mount cam lever shafts (3).

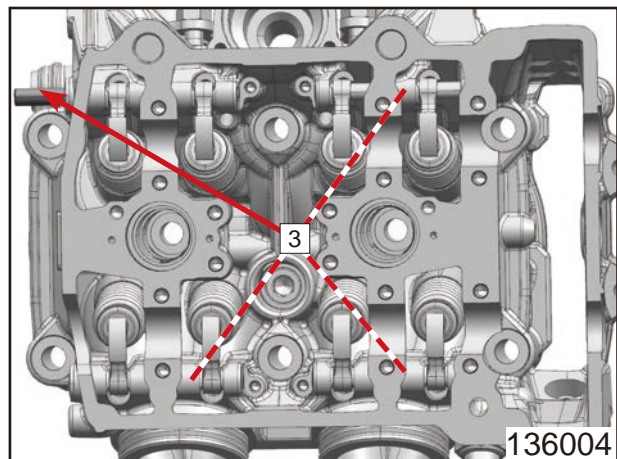

Mount and tighten screws (2).

**Guideline**

Screw, cam lever axial lock
M5
6 N•m
243 Thread locker

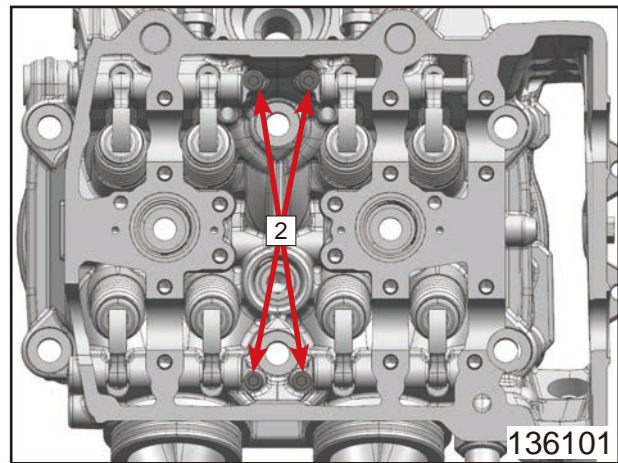

Mount screw plugs (1) with new O-rings.

**Guideline**

Screw plug, cam lever axis
M10x1
10 N•m

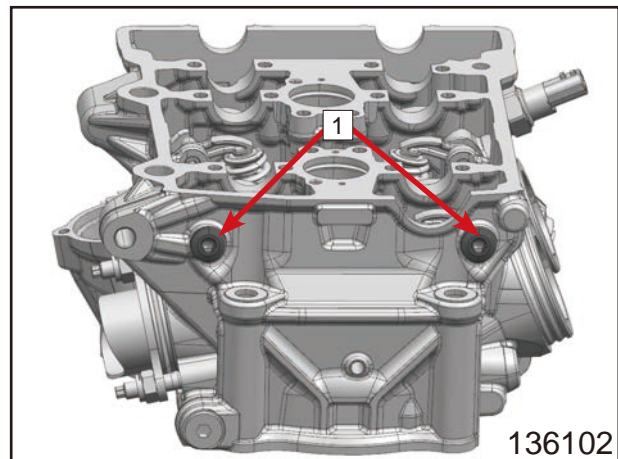

**13.4.23 Checking the Cylinder Head**

Check valve guides (1) using a limit plug gauge.

If the gauge is easy to insert into the valve guide: Change the valve guide and valve.

Check the sealing surface of the spark plug thread and the valve seats for damage and cracking.

If there is damage or cracking: Change the cylinder head.

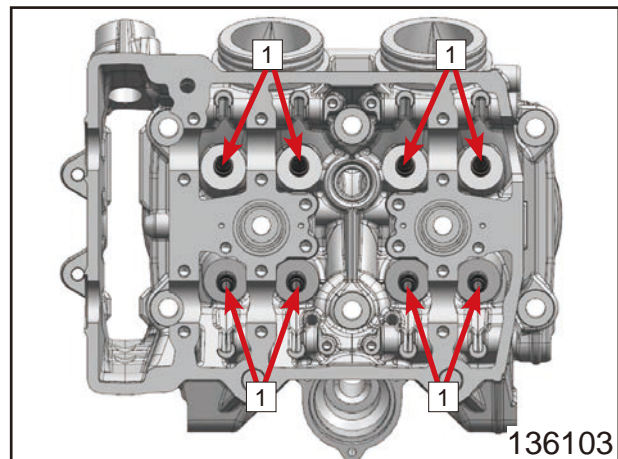

Check the sealing surface of the cylinder for distortion using a straightedge and a feeler gauge.

Cylinder/cylinder head - sealing area distortion
≤ 0.05 mm

If the measured value does not meet specifications: Change the cylinder head.

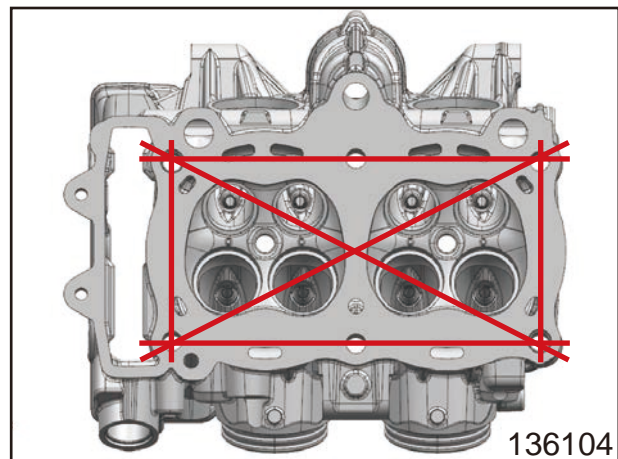

© CFMOTO Powersports, Inc. This manual is subject to all applicable copyright laws. Reproduction or duplication in any form, whole or in part, is strictly prohibited.

# CFMOTO

Check sealing seat (A) of the valves.

Valve - sealing seat width	
Intake	2.80 mm
Valve - sealing seat width	
Exhaust	3.00 mm

If the measured value does not meet specifications: Machine the valve seat.  
Blow compressed air through all oil channels and oil nozzles, and check that they are clear.

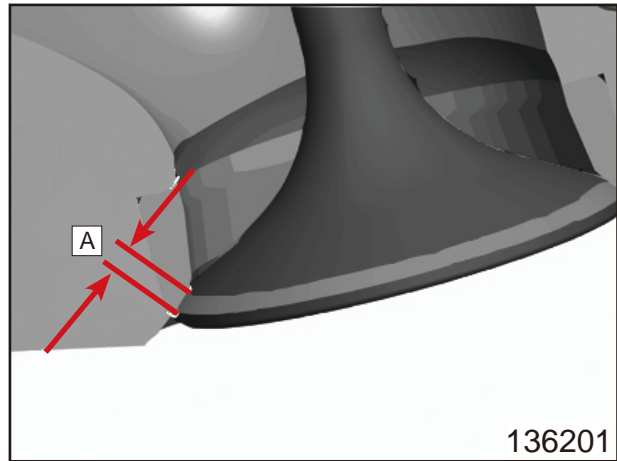

Check valve (2) for damage and wear.

If there is damage or wear: Change the valve.

Check the valve for run-out.

Valve - run-out	
On the valve plate	≤ 0.05 mm
On the valve stem	≤ 0.05 mm

If the measured value does not meet specifications: Change the valve.

Check the valve stem diameter.

Valve - valve stem diameter	
Exhaust	
4.95mm~4.97 mm	
Intake	
4.97mm~4.99 mm	

If the measured value does not meet specifications: Change the valve.

Check valve spring (3) for damage and wear.

If there is damage or wear: Change the valve spring.

Measure the length of the valve springs.

Valve spring	
Minimum length (without valve spring seat)	
44.0 mm	

If the measured value does not meet specifications: Change the valve springs.

Check cam levers (4) for damage and wear.

If there is damage or wear: Change the cam lever.

Check cam lever shafts (5) for damage and wear.

If there is damage or wear: Change the

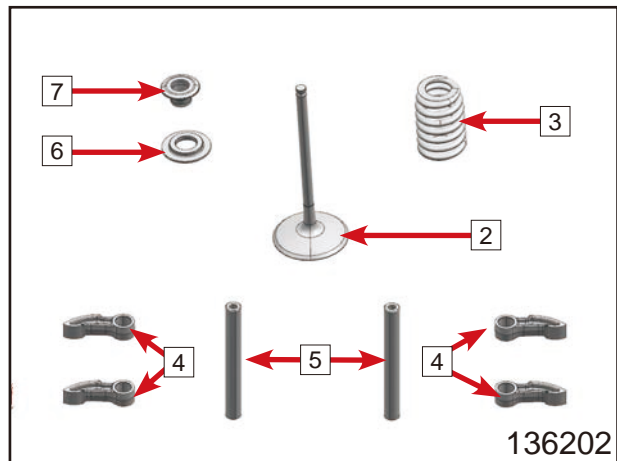

cam lever shaft.

Check valve spring seat (6) for damage and wear.

If there is damage or wear: Change the valve spring seat.

Check valve spring retainer (7) for damage and wear.

If there is damage or wear: Change the valve spring retainer.

### 13.4.24 Checking the Clutch

Check clutch push rod (1) for damage and wear.

If there is damage or wear: Change clutch push rod.

Check axial bearing (2) for damage and wear.

If there is damage or wear: Change the axial bearing.

Check the length of clutch springs (3).

Clutch spring - length	$\geq 43.0$ mm
------------------------	----------------

If the clutch spring length is shorter than specified: Change all clutch springs.

Check the contact surface of clutch pressure cap (4) for damage and wear.

If there is damage or wear: Change the clutch pressure cap.

Check the thrust surfaces of the clutch facing discs in clutch basket (5) for damage and wear.

If there is damage or wear: Change the clutch disc pack and the clutch basket.

Check needle bearing (6) for damage and wear.

If there is damage or wear: Change the needle bearing.

Check intermediate clutch discs (7) for damage and wear.

If the intermediate clutch discs are not level and are pitted: Change the clutch disc pack.

Check clutch facing discs (8) for discoloration and scoring.

If there is discoloration or scoring: Change the clutch disc pack.

Check the thickness of the clutch disc pack.

Clutch disc pack - thickness	
New condition	35.60mm~36.50 mm
Wear limit	34.80 mm

If the clutch disc pack does not meet specifications: Change the clutch disc pack.

Check pretension ring (9) and support ring (10) for damage and wear.

If there is damage or wear: Change the pretension ring and support ring.

Check inner clutch hub (11) for damage and wear.

If there is damage or wear: Change the inner clutch hub.

Check springs (12) of the clutch basket for damage and wear.

If there is damage, wear or play in the direction of rotation: Change the clutch basket.

© CFMOTO Powersports, Inc. This manual is subject to all applicable copyright laws. Reproduction or duplication in any form, whole or in part, is strictly prohibited.

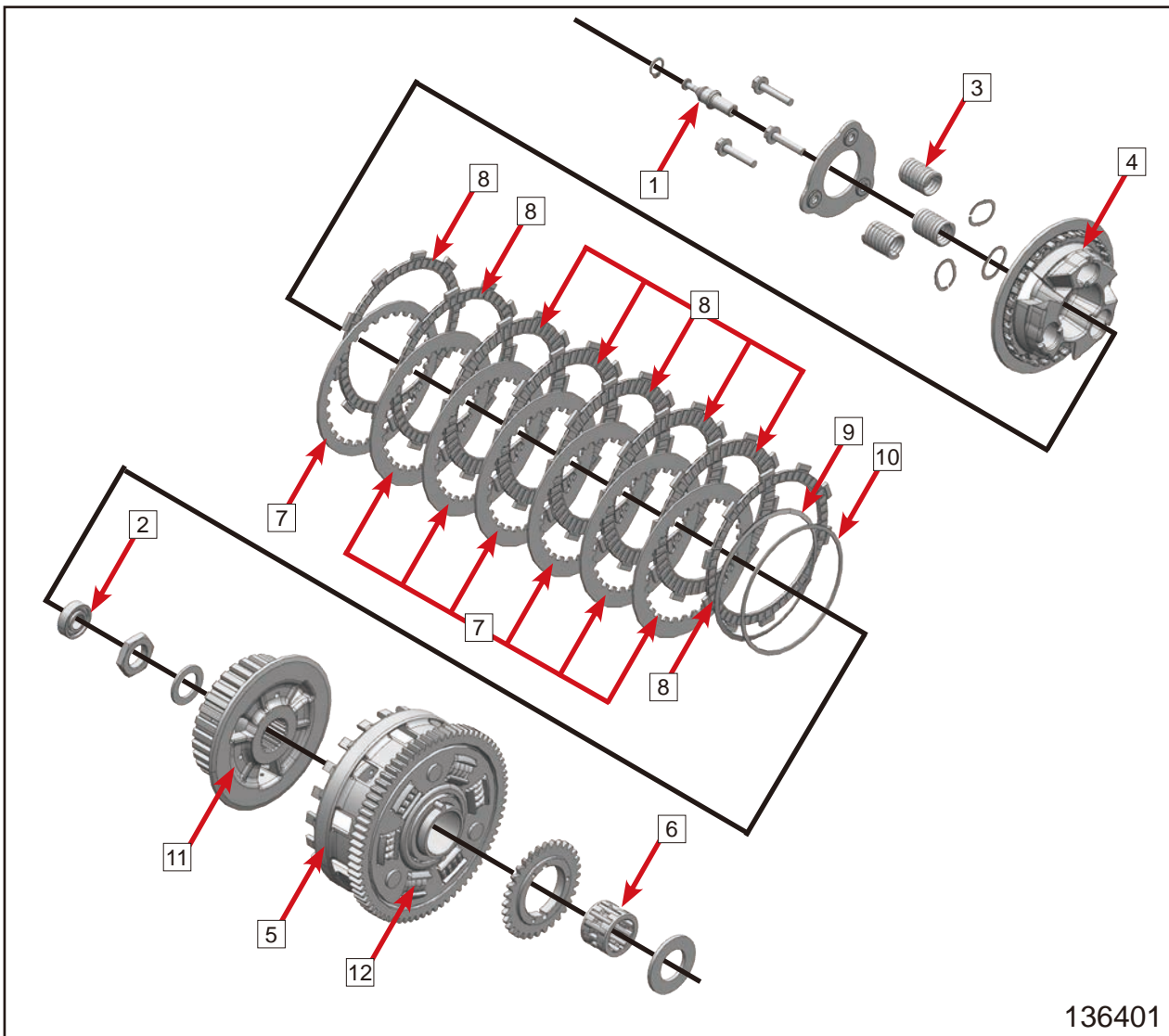

136401

**13.4.25 Removing the Shift Drum Locating Unit**

Clamp shift drum.

**Guideline**

Use soft jaws.

Remove screw (1).

Take off the shift drum locating unit (2).

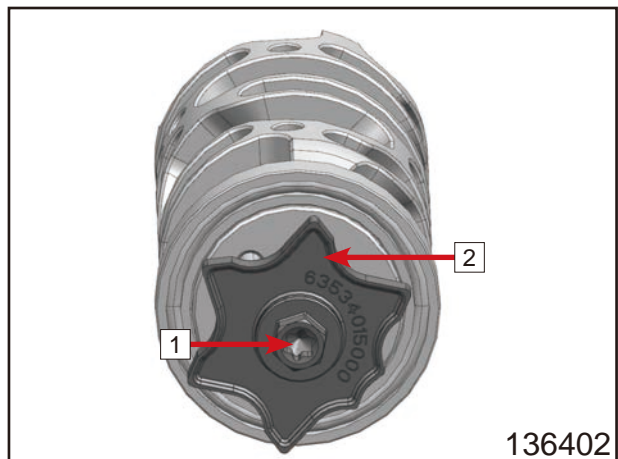

136402

Remove bearing (3).

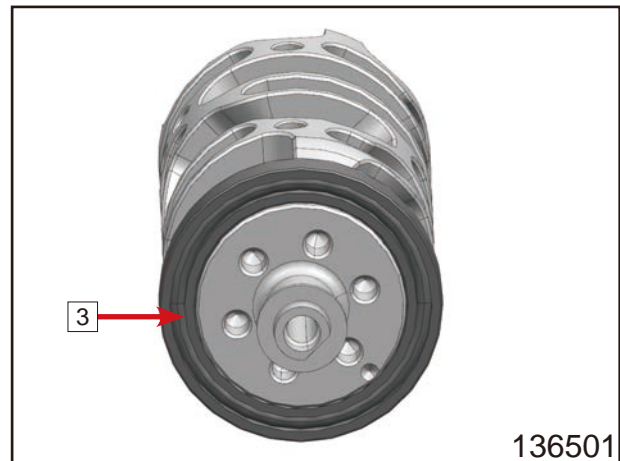

### 13.4.26 Checking the Shift Mechanism

Check shift forks (1) on plate (A) for damage and wear (visual check).

If there is damage or wear: Change the shift fork and gear wheel pair.

Check shift grooves (B) of shift drum (2) for wear.

If the shift groove is worn: Change the shift drum.

Check the seat of the shift drum in bearings (3).

If the shift drum is not seated correctly: Change the shift drum and/or the bearing.

Check bearings (3) for ease of movement and wear.

If the bearings are stiff or are worn: Change the bearings.

Check shift rails (4) on a flat surface for run-out.

If there is run-out: Change the shift rail.

Check the shift rails for scoring, wear and smooth operation in the shift forks.

If there is scoring or corrosion, or if the shift fork is stiff: Change the shift rail.

Check sliding plate (5) in contact areas (C) for wear.

If the sliding plate is worn: Change the sliding plate.

Check return surface (D) on the sliding plate for wear.

If deep notches are present: Change the sliding plate.

Check guide pin (E) for looseness and wear.

If the guide pin is loose and/or worn: Change the sliding plate.

Preassemble the shift shaft.

© CFMOTO Powersports, Inc. This manual is subject to all applicable copyright laws. Reproduction or duplication in any form, whole or in part, is strictly prohibited.

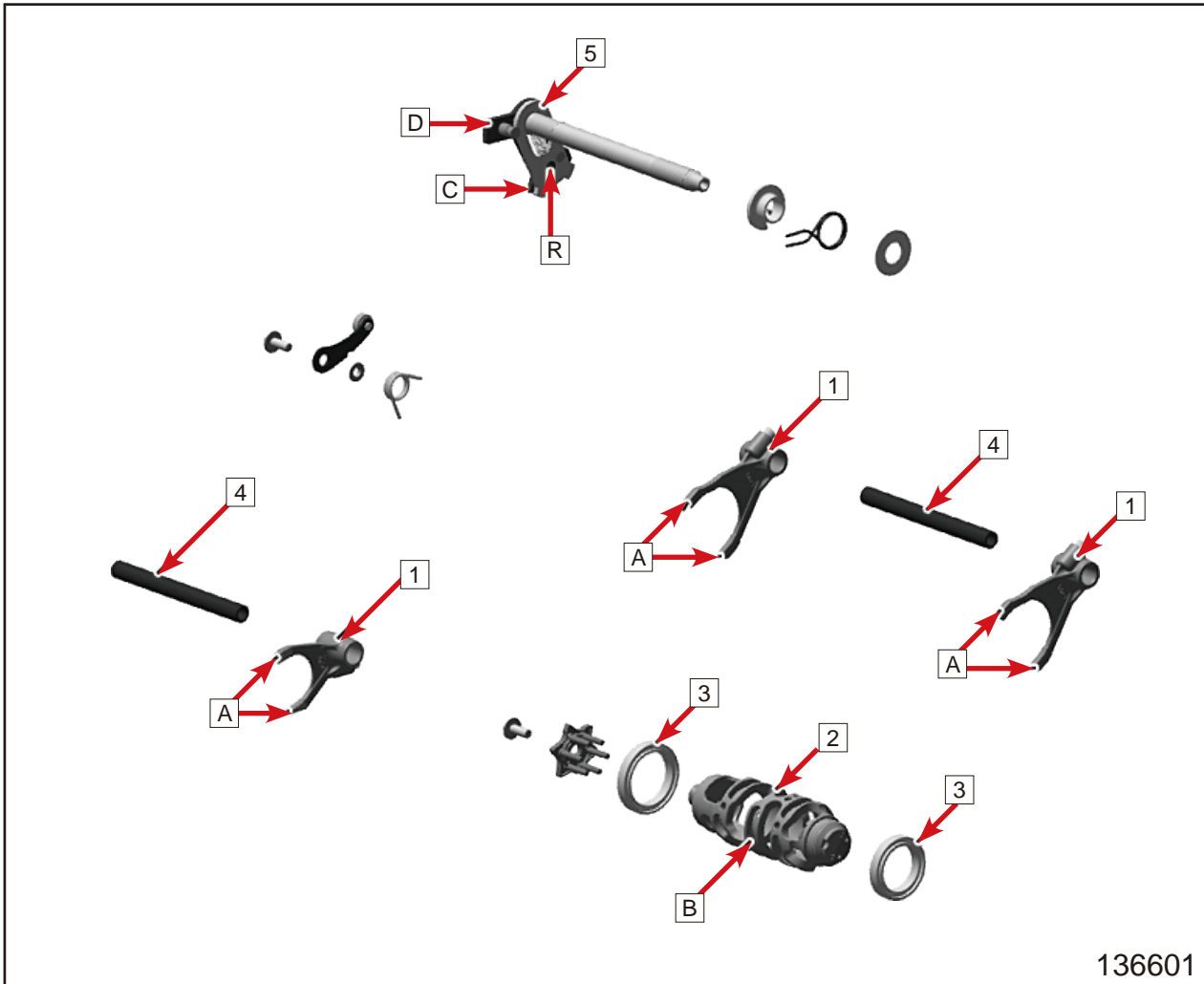

Check clearance (F) between the sliding plate and the shift quadrant.

Shift shaft - play in sliding plate/shift quadrant
0.40mm~ 0.80 mm

If the measured value does not meet specifications:  
Change the sliding plate.

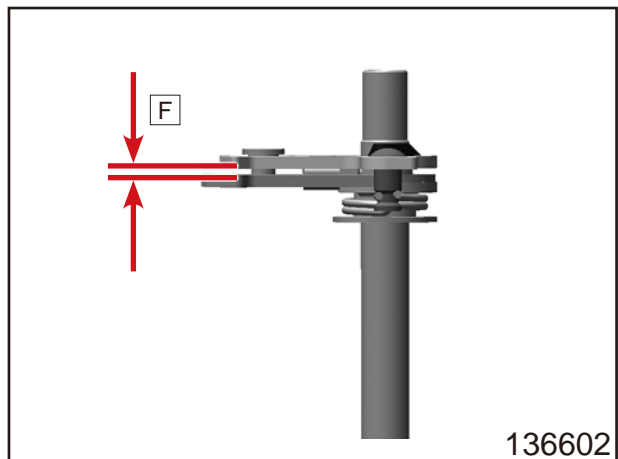

## 13.4.27 Preassembling the Shift Shaft

Fix the short end of the shift shaft in a vise.

### Guideline:

Use soft jaws.

Mount sliding plate (1) with the guide pin facing down and attach the guide pin to the shift quadrant.

Mount pressure spring (2).

Push on spring guide (3), push return spring (4) over the spring guide with the offset end facing upward and lift the offset end over abutment bolt (5).

Mount stop disk (6).

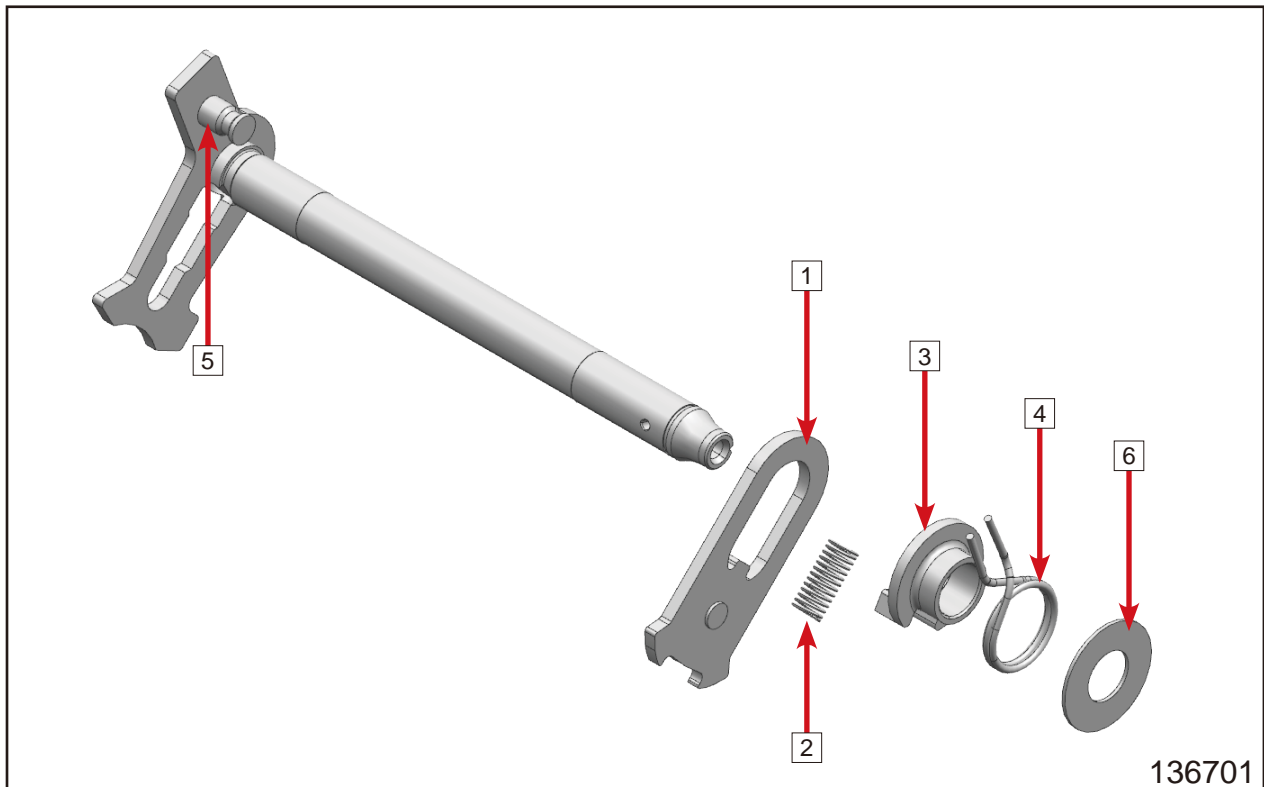

## 13.4.28 Installing the Shift Drum Locating Unit

Clamp shift drum.

### Guideline

Use soft jaws.

Mount bearing (1).

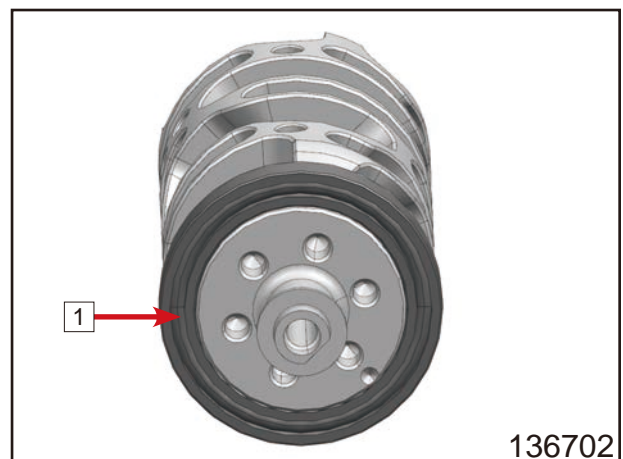

# CFMOTO

Position shift drum locating unit (2).  
The flat surface (A) of the shift drum engages in the flat surface (B) of the shift drum locating unit.  
Mount and tighten screw (3).

**Guideline:**

Screw, shift drum locating
M6
10 N•m
243 Thread locker

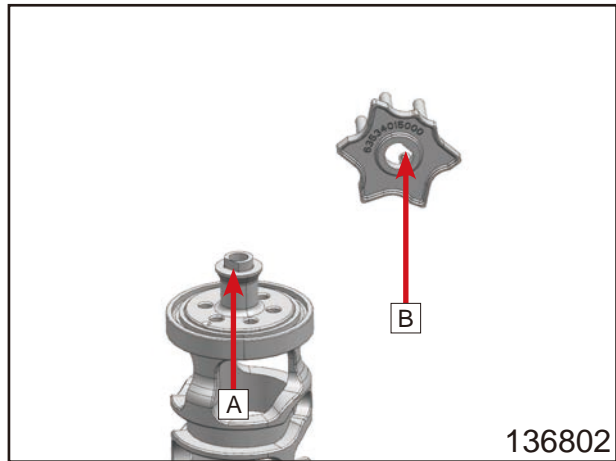
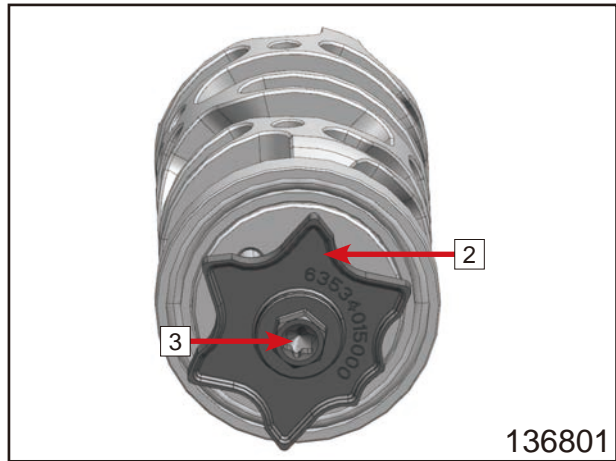

## 13.4.29 Disassembling the Main Shaft

Remove oil nozzle (1).

Secure the main shaft in the vise with the gear teeth facing downward.

### Guideline

Use soft jaws.

Remove stop disk (2) and second-gear fixed gear (3).

Remove sixth-gear idler gear (4).

Remove needle bearing (5) and stop disk (6).

Remove lock ring (7).

Remove third/fourth-gear sliding gear (8).

Remove lock ring (9).

Remove stop disk (10) and fifth-gear idler gear (11).

Remove needle bearing (12).

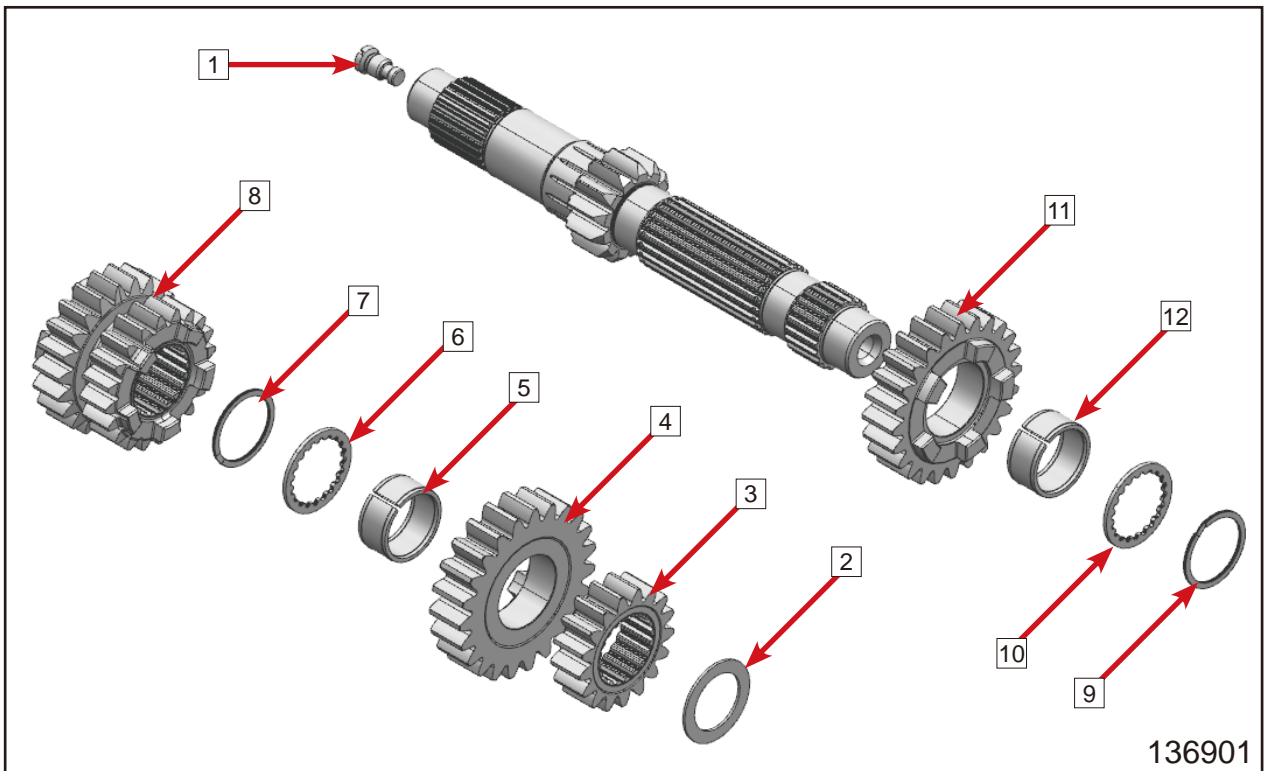

## 13.4.30 Disassembling the Countershaft

Remove bearing (1) with distance sleeve (2).

Secure the countershaft in the bench vise with the toothed end facing downward.

### Guideline

Use soft jaws.

Remove bearing (3).

Remove stop disk (4) and first-gear idler gear (5).

Remove needle bearing (6) and stop disk (7).

Remove the fifth-gear sliding gear (8) and lock ring (9).

Remove stop disk (10) and fourth-gear idler gear (11).

Remove needle bearing (12) and third-gear idler gear (13).

Remove needle bearing (14) and stop disk (15).

Remove lock ring (16) and sixth-gear sliding gear (17).

Remove lock ring (18) and stop disk (19).

Remove second-gear idler gear (20) and needle bearing (21).

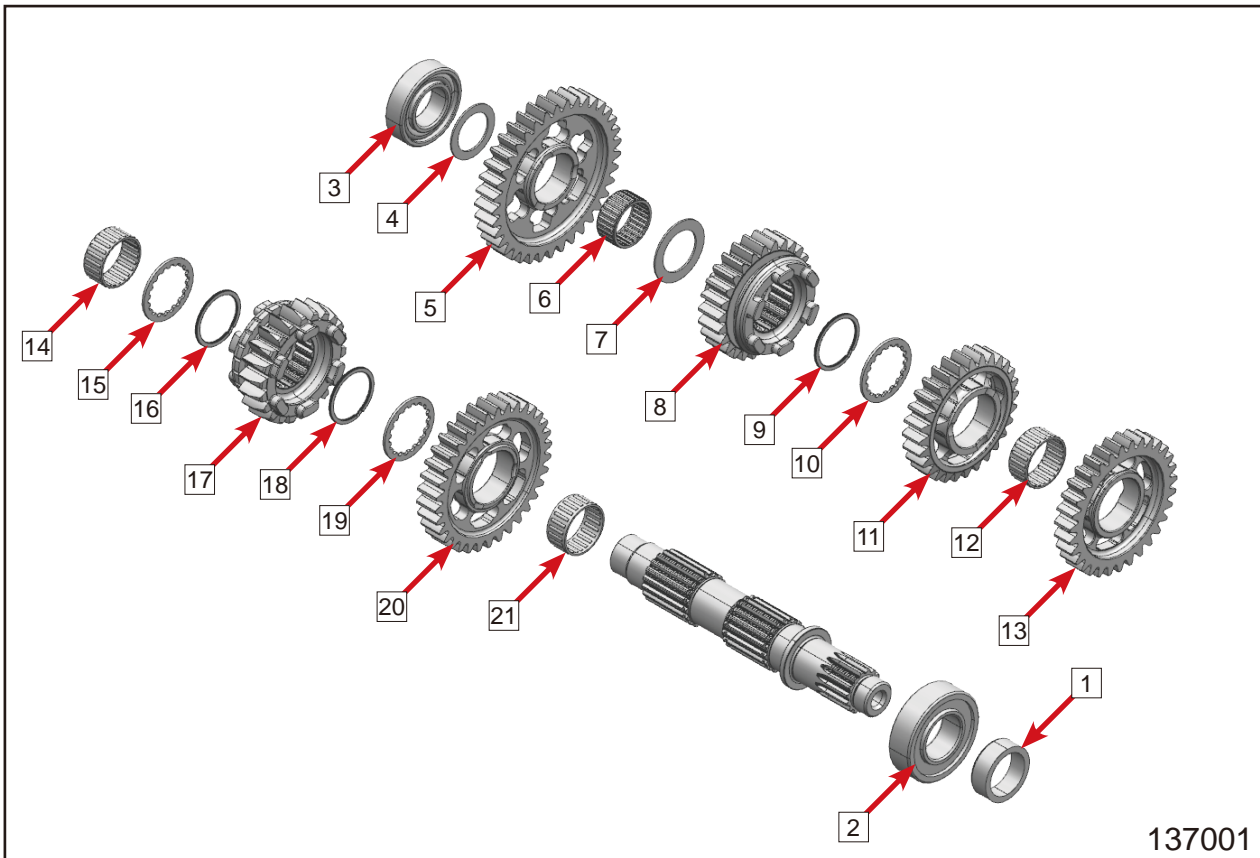

## 13.4.31 Checking the Transmission

Check needle bearings (1) for damage and wear.

If there is damage or wear:

Change the needle bearing.

Check the pivot points of main shaft (2) and countershaft (3) for damage and wear.

If there is damage or wear: Change the main shaft and/or countershaft.

Check the tooth profiles of main shaft (2) and countershaft (3) for damage and wear.

If there is damage or wear: Change the main shaft and/or countershaft.

Check the pivot points of idler gears (4) for damage and wear.

If there is damage or wear: Change the gear wheel pair.

Check the shift dogs of idler gears (4) and sliding gears (5) for damage and wear.

If there is damage or wear: Change the gear wheel pair.

Check the tooth faces of idler gears (4), sliding gears (5), and fixed gear (6) for damage and wear.

If there is damage or wear: Change the gear wheel pair.

Check the tooth profiles of sliding gears (5) for damage and wear.

If there is damage or wear: Change the gear wheel pair.

Check sliding gear (5) for smooth operation in the profile of main shaft (2).

If the fixed gear is stiff: Change the sliding gear or the main shaft.

Check sliding gears (5) for smooth operation in the profile of countershaft (3).

If the fixed gear is stiff: Change the sliding gear or the countershaft.

Check stop disks (7) for damage and wear.

If there is damage or wear: Change the stop disks.

Use new lock rings (8) with every repair.

Check bearings (9) for damage and wear.

If there is damage or wear: Change the bearings.

Check distance sleeve (10) for damage and wear.

If there is damage or wear: Change distance sleeve.

Check oil nozzle (11) to ensure that they are free.

If the oil nozzle is blocked: Clean the oil nozzle and change as necessary.

© CFMOTO Powersports, Inc. This manual is subject to all applicable copyright laws. Reproduction or duplication in any form, whole or in part, is strictly prohibited.

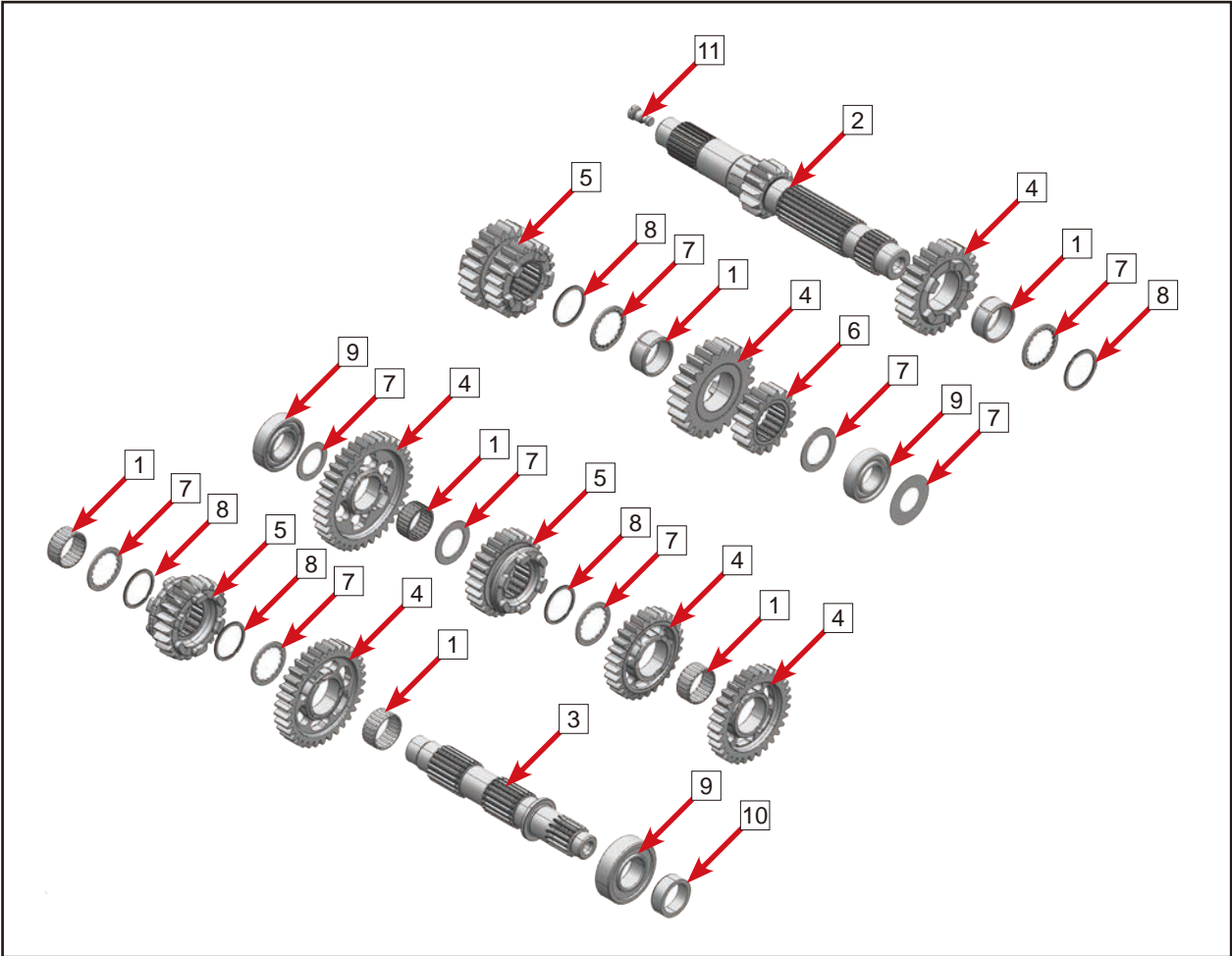

## 13.4.32 Assembling the Main Shaft

### NOTE

Use new lock rings with every repair.

### Preparatory Work

Carefully lubricate all parts before assembling.  
Check the transmission.

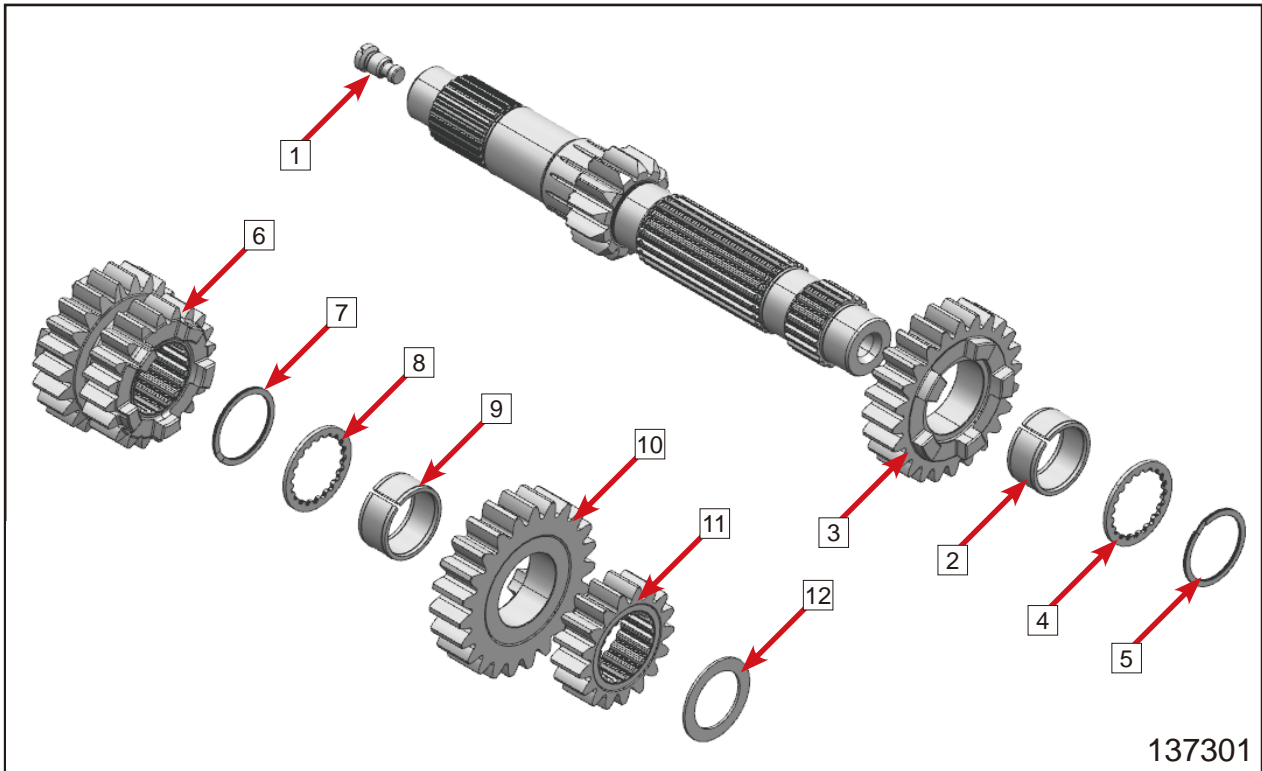

137301

### Main Work

Mount and tighten oil nozzle (1).

### Guideline

Oil nozzle for clutch lubrication

M8

5 N•m

43 Thread locker

### NOTE

Ensure that there is no thread locker in the hole.

Secure the main shaft in the vise with the gear teeth facing downward.

### Guideline

Use soft jaws.

Mount needle bearing (2), and mount fifth-gear idler gear (3) with the shift dogs facing up.

Mount stop disk (4).

Mount new lock ring (5).

The lock ring engages in the groove of the transmission shaft.

Attach third/fourth-gear sliding gear (6) with the small gear wheel facing up.

Mount new lock ring (7).

The lock ring engages in the groove of the transmission shaft.

Mount stop disk (8) and needle bearing (9).

Mount sixth-gear idler gear (10) with the shift dogs facing downward.

Mount second-gear fixed gear (11) with the collar facing downward and mount stop disk (12).

Finally, check all the gear wheels for smooth operation.

### 13.4.33 Assembling the Countershaft

#### NOTE

Use new lock rings with every repair.

#### Preparatory Work

Carefully lubricate all parts before assembling.

Check the transmission.

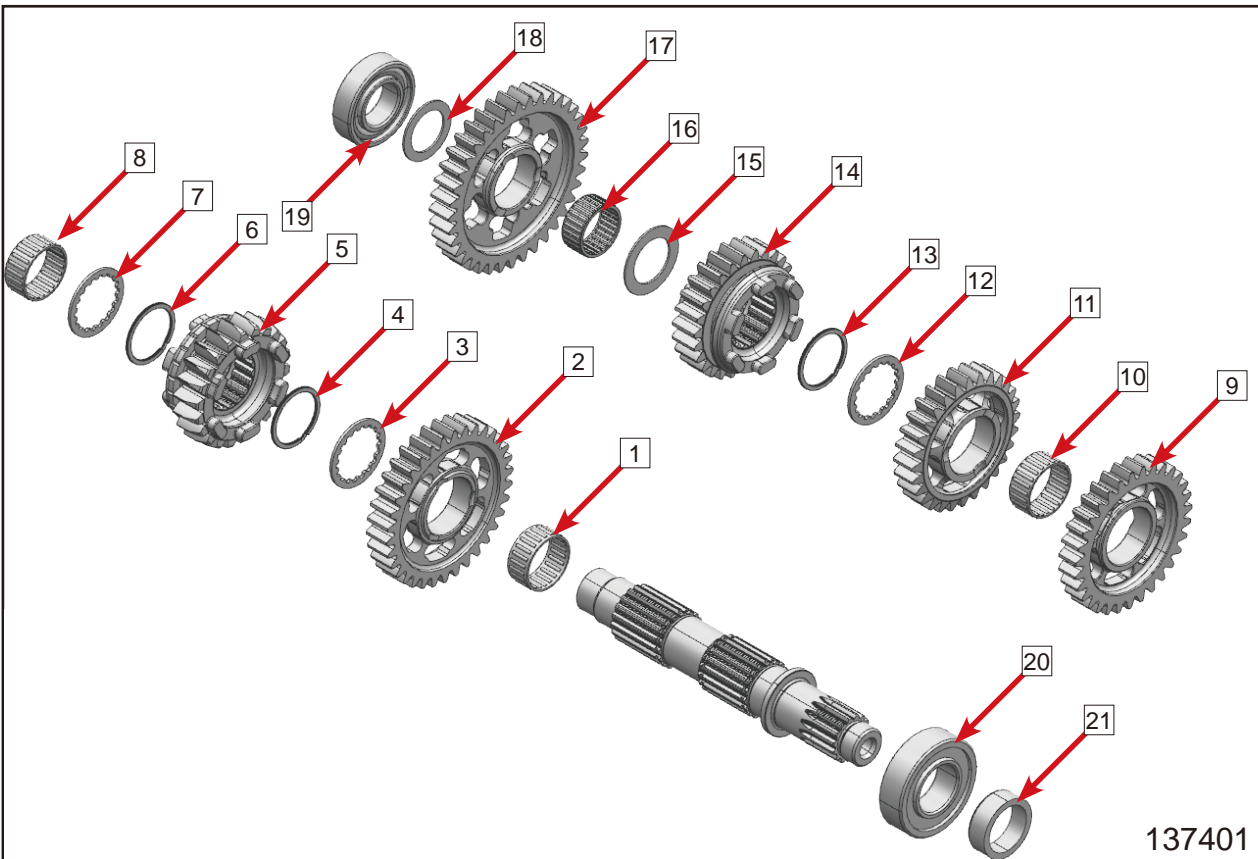

137401

#### Main Work

Secure the countershaft in the bench vise with the toothed end facing downward.

#### Guideline

Use soft jaws.

Mount needle bearing (1) and second-gear idler gear (2) onto the countershaft with the protruding collar facing downward.

Mount stop disk (3).

Mount new lock ring (4).

The lock ring engages in the groove of the transmission shaft.

Mount the sixth-gear sliding gear (5) with the shift groove facing up.

Mount new lock ring (6).

The lock ring engages in the groove of the transmission shaft.

Mount stop disk (7).

Mount needle bearing (8) and the third-gear idler gear (9) with the collar facing up.  
Mount needle bearing (10) and the fourth-gear idler gear (11) with the collar facing down.  
Mount stop disk (12).  
Mount new lock ring (13).  
The lock ring engages in the groove of the transmission shaft.  
Mount the fifth-gear sliding gear (14) with the shift groove facing down and stop disk (15).  
Mount needle bearing (16) and first-gear idler gear (17) with the recess facing down, and stop disk (18).  
Mount bearing (19).  
Take the countershaft out of the vise.  
Mount distance sleeve (20) with bearing (21).  
Finally, check all the gear wheels for smooth operation.

### 13.4.34 Checking the Electric Starter Drive

Check the gear teeth and bearing of starter intermediate gear (1) for damage and wear.  
If there is damage or wear:  
Change the starter intermediate gear.  
Check the gear teeth and bearing of torque limiter (2) for damage and wear.  
If there is damage or wear: Change torque limiter.  
Check gear mesh and bearing of freewheel gear (3) for damage and wear.  
If there is damage or wear: Change freewheel gear or bearing.  
Check freewheel (4) for damage and wear.  
If there is damage or wear: Change the freewheel.  
Check the gear teeth of the starter motor (5) for damage and wear.  
If there is damage or wear: Change starter motor.  
Change O-ring (6) of the starter motor.  
Connect negative cable of a 12-volt power supply to the housing of the starter motor.  
Connect positive cable of the power supply briefly with the connector of the starter motor.  
If the starter motor does not turn when the circuit is closed: Change starter motor.

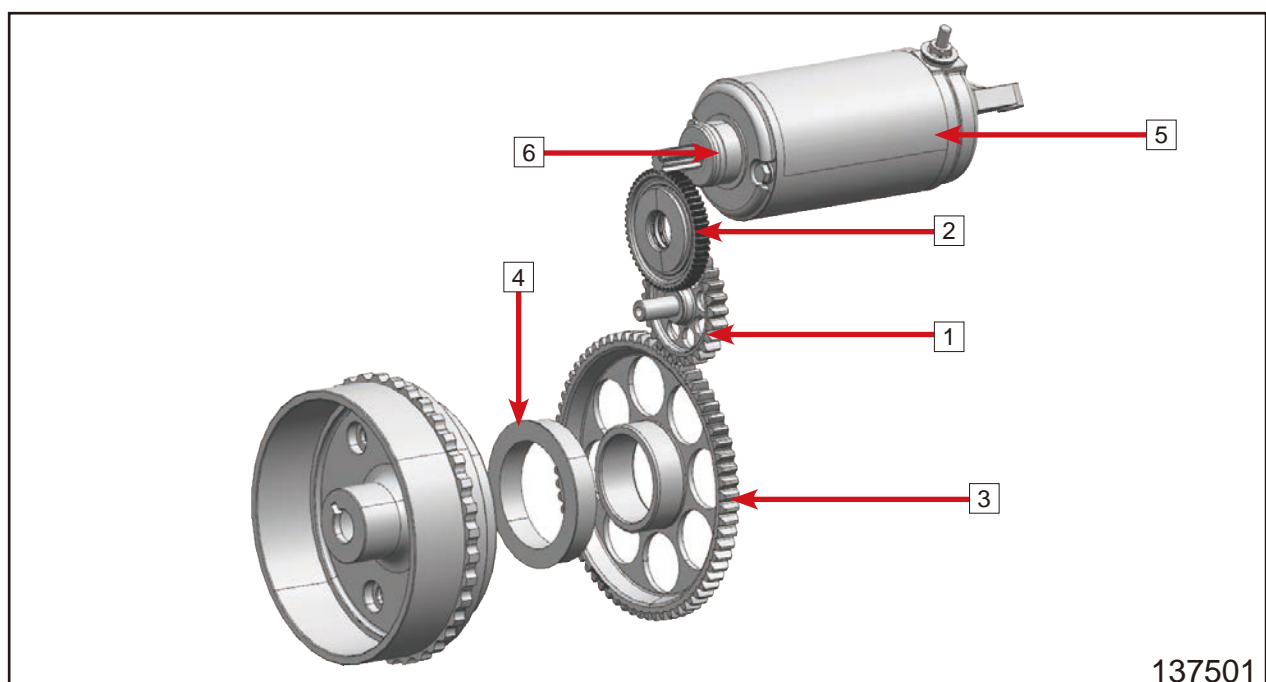

137501

## 13.4.35 Checking the Freewheel

Insert freewheel gear (1) into the freewheel hub while turning the freewheel gear counterclockwise; do not wedge it.

Check the locking action of freewheel gear (1).

The freewheel gear cannot be turned counterclockwise and does not block clockwise:

Change the freewheel.

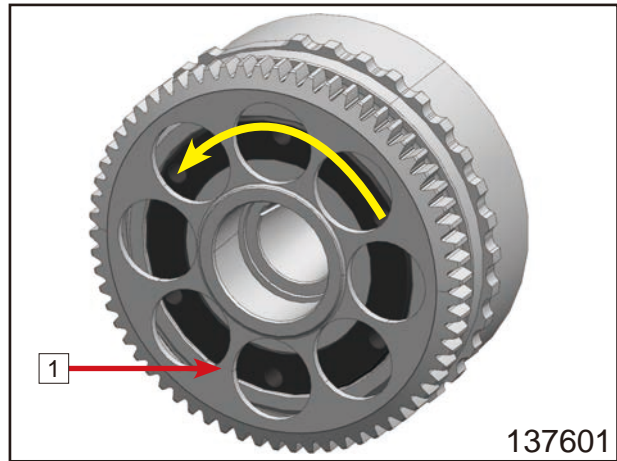

## 13.4.36 Working on the Alternator Cover

Remove the cable retainer (1).

Pull the rubber grommet out of the engine case.

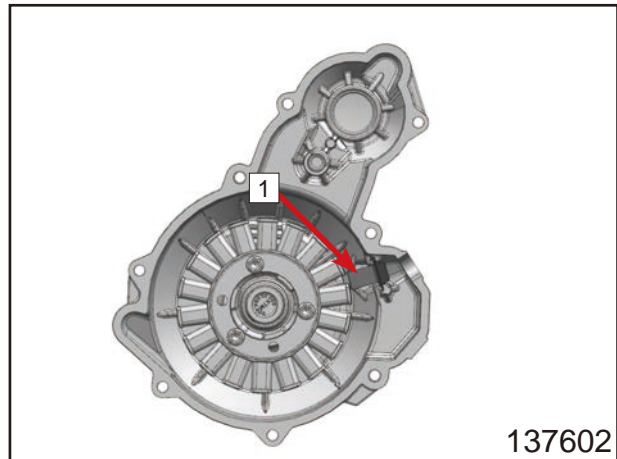

Remove screws (2).

Remove the stator.

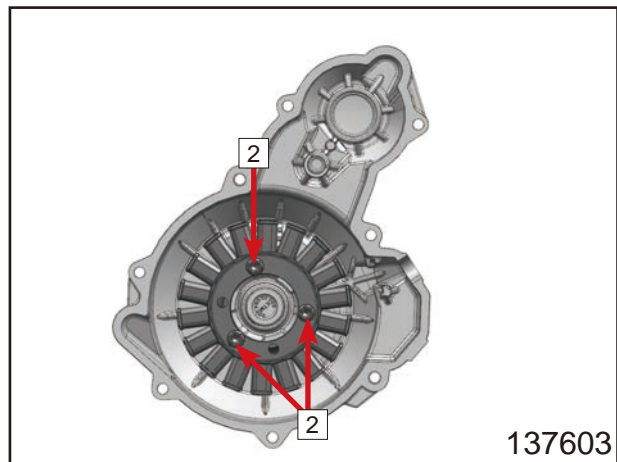

Remove bearing (3) using a proper bearing puller.

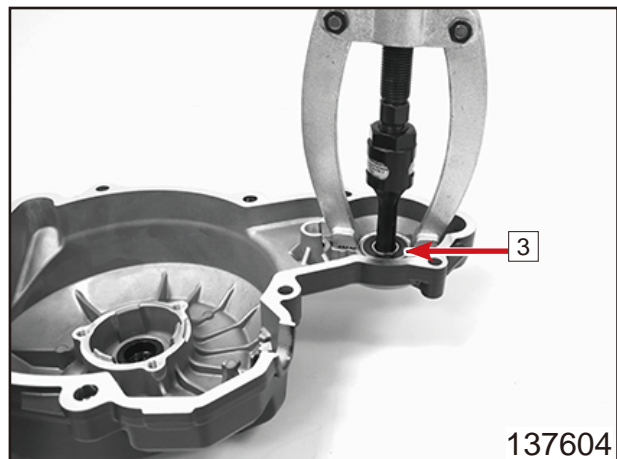

Press in new bearing (3) all the way using a suitable tool.

**NOTE**

Provide suitable support for the alternator cover while pressing in.

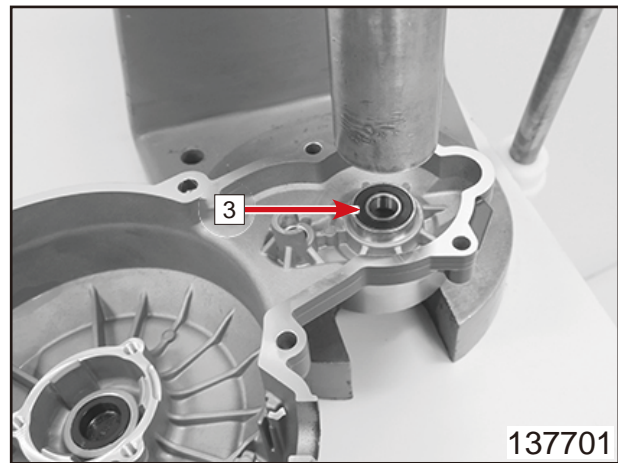

Position the stator.  
Mount and tighten screws (2).

**Guideline**

Screw, stator
M6
10 N•m
243 Thread locker

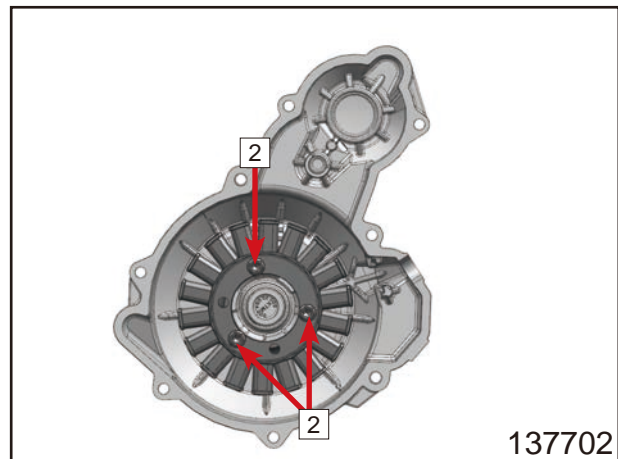

Apply sealing compound lightly in the area of the rubber grommet.  
Position the rubber grommet in the alternator cover.  
Position the cable retainer (1).  
The retaining bracket engages in the attachment (A).

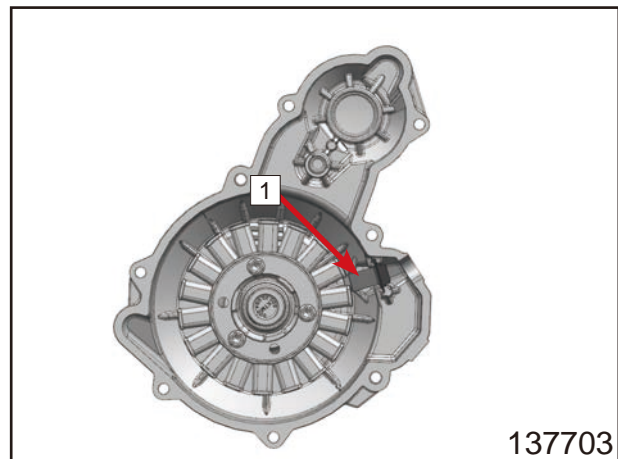

© CFMOTO Powersports, Inc. This manual is subject to all applicable copyright laws. Reproduction or duplication in any form, whole or in part, is strictly prohibited.

## 13.5 Engine Assembly

### 13.5.1 Installing the Piston

#### NOTE

The operations are the same for both pistons.

Clamp connecting rod in the vise.

#### Guideline

Use soft jaws.

Position piston on the associated connecting rod.

Mount piston pin (1).

The piston marking (A) and lettering (B) of the connecting rod point forward after assembly.

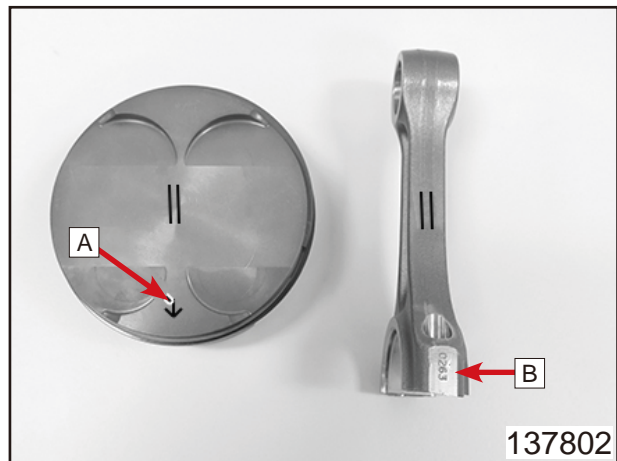
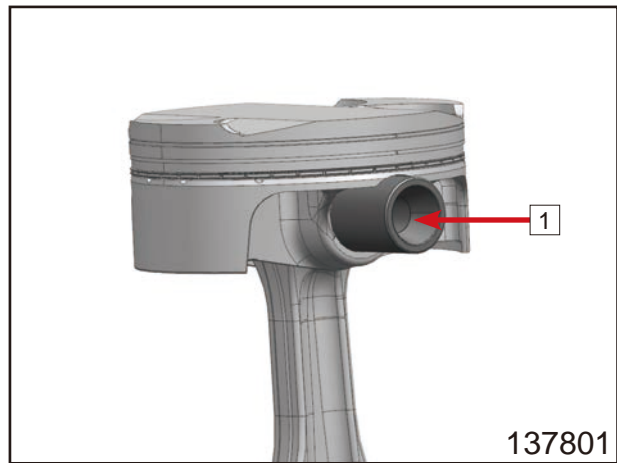

Position the new piston ring lock (2).

Insert the special tool (D) and press it with force towards the piston.

Turn the special tool (D) (Insertion for piston ring lock) clockwise, thereby pushing the piston ring lock into the groove.

Insertion for Piston Ring Lock  
(See Section 13.1 for details.)

Ensure that the piston ring lock is in the correct position on both sides.

The open side (C) of the piston ring lock faces upwards.

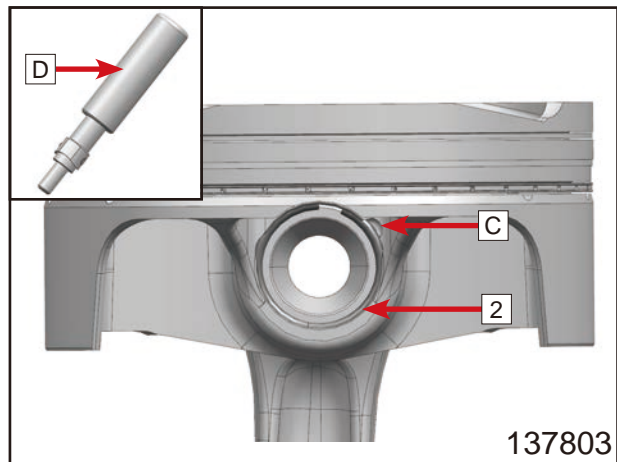

Oil the cylinder and piston.

Shift the gap of the piston rings by 120°.

Mount piston ring compressor (3) on the piston.

Clamp the piston rings together using the tool.

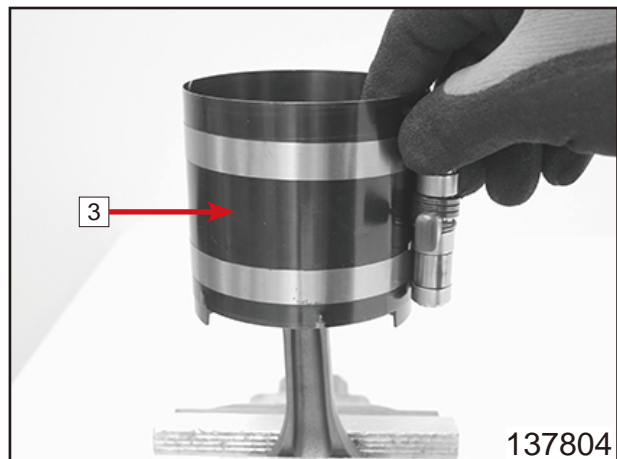

Position the piston with the tool on the cylinder.

Tap lightly on the piston ring compressor from the top with a plastic hammer so that it lies flush with the cylinder.

**NOTE**

The tool must press the piston rings together properly and lie flush with the cylinder.

Drive the piston into the cylinder by striking it carefully with the hammer handle.

**NOTE**

The piston rings should not catch or they will be damaged.

Ensure that piston marking (A) faces the exhaust side.

### 13.5.2 Installing the Oil Spray Tube

Mount the new O-ring (1) on the oil spray tube (2).

Mount the oil spray tube.

The pin (A) engages in the recess (B).

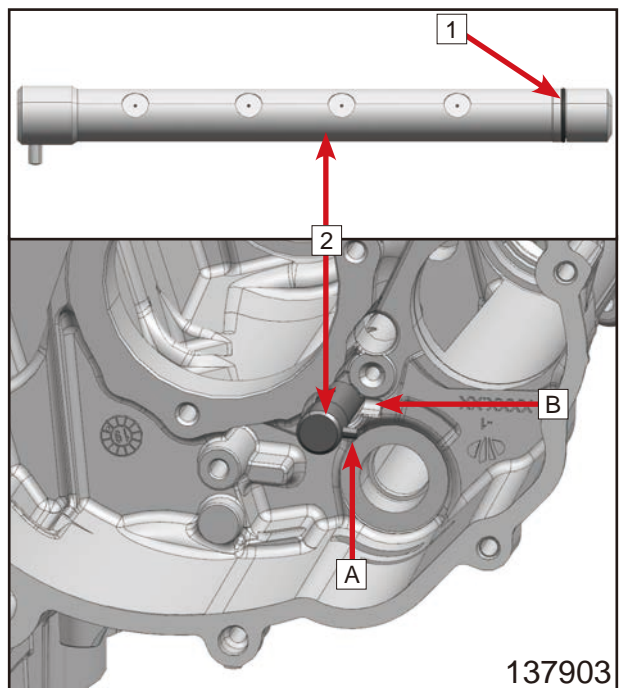
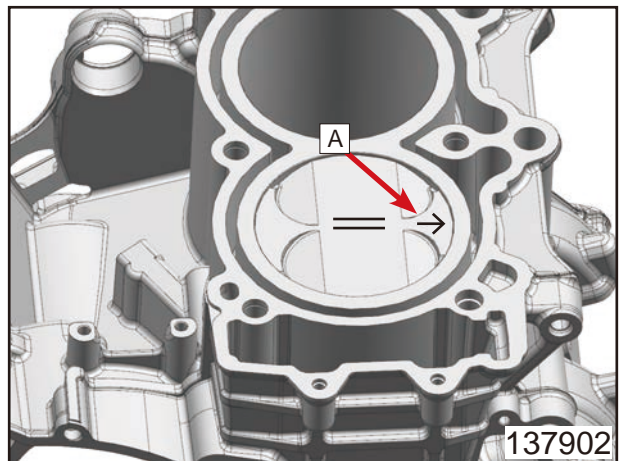
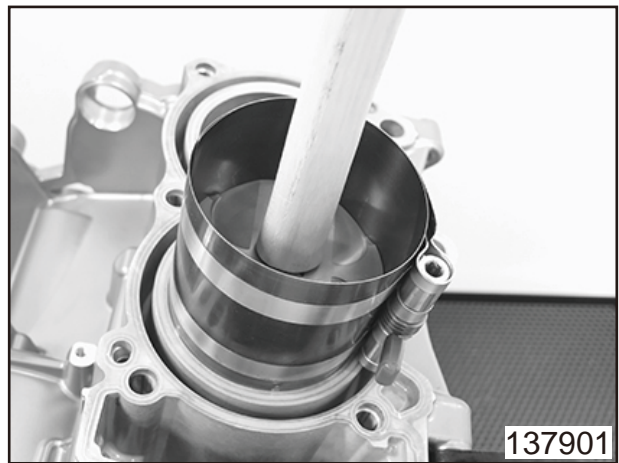

## 13.5.3 Installing the Transmission Shafts

### Preparatory Work

Oil all bearings.

### Main Work

Mount shift drum (1).

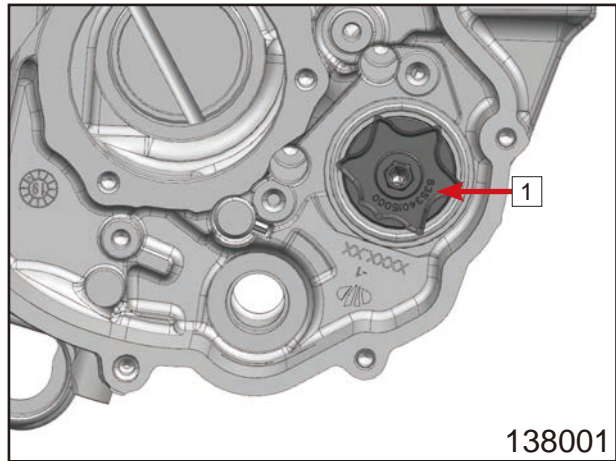

Mount main shaft (2).

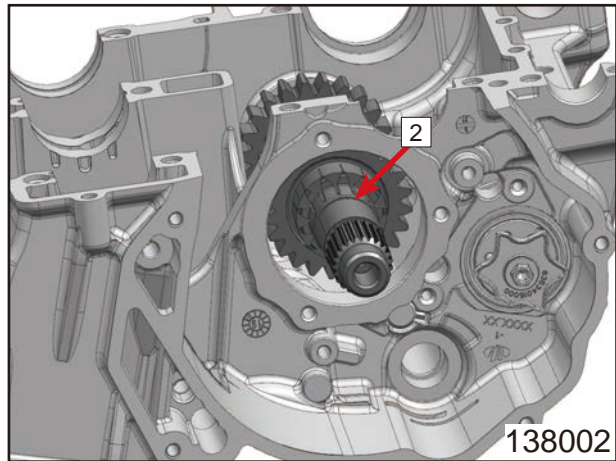

Position shift fork (3).

Mount shift rail (4).

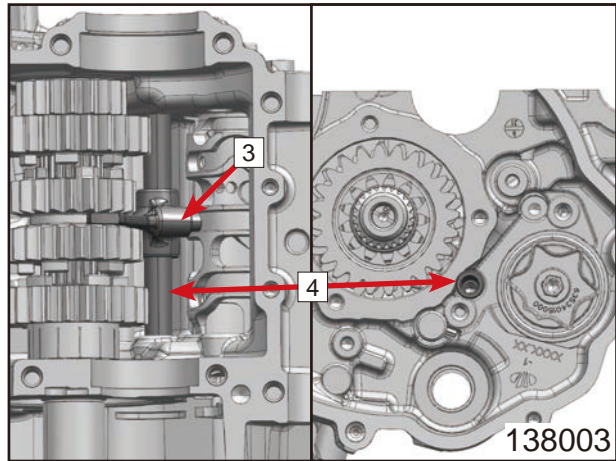

Position shift forks (5).

Mount shift rail (6).

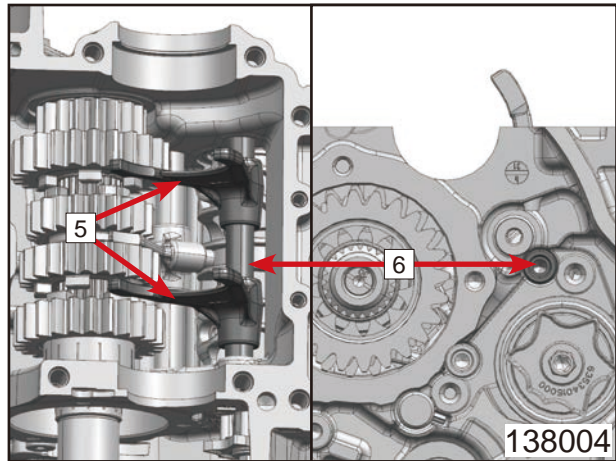

Position retaining bracket (7).  
Mount and tighten screw (8).

**Guideline**

Screw, shift drum retaining bracket
M5
6 N•m
243 Thread locker

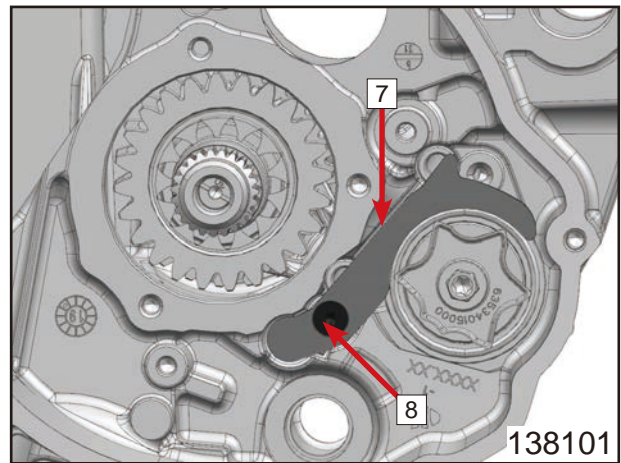

Position bearing support (9) with bearing.  
Mount and tighten screws (10).

**Guideline**

Screw, main shaft bearing support
M6
10 N•m
243 Thread locker

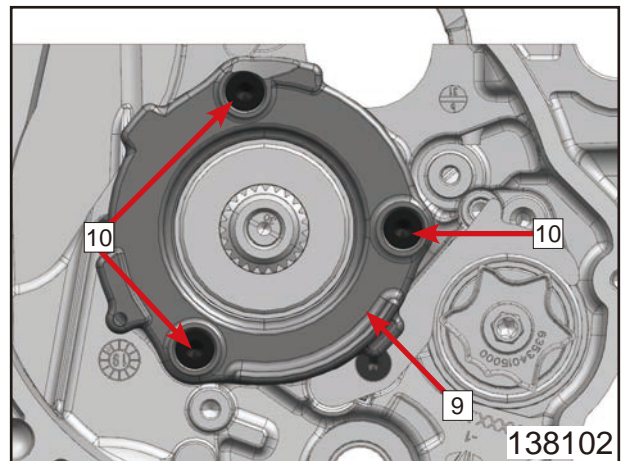

Position countershaft (11)  
Mount radial shaft seal ring (12).

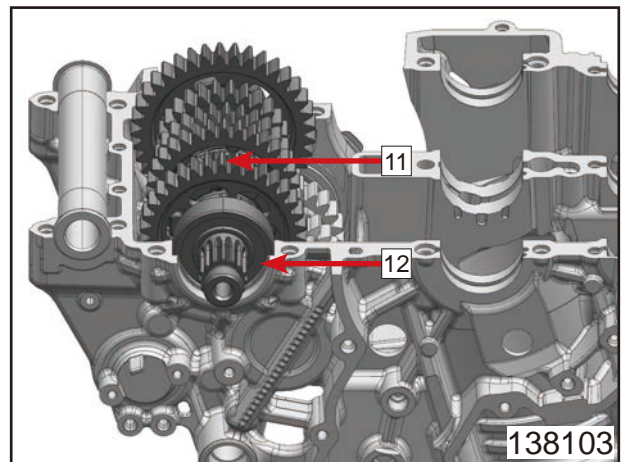

**13.5.4 Installing the Lower Engine Case**

Oil the bearing shells.

Position crankshaft with timing chain (1).

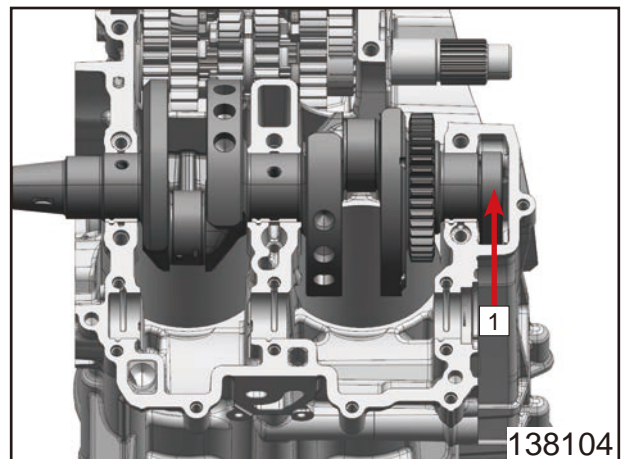

© CFMOTO Powersports, Inc. This manual is subject to all applicable copyright laws. Reproduction or duplication in any form, whole or in part, is strictly prohibited.

# CFMOTO

Oil the bearing shells.

There is no oil or grease on the connecting rod joint face.

Position conrod bearing covers (2) and (3) on the associated connecting rod.

## NOTE

The markings (A) on the connecting rod and conrod bearing cover must be identical and legible from the front.

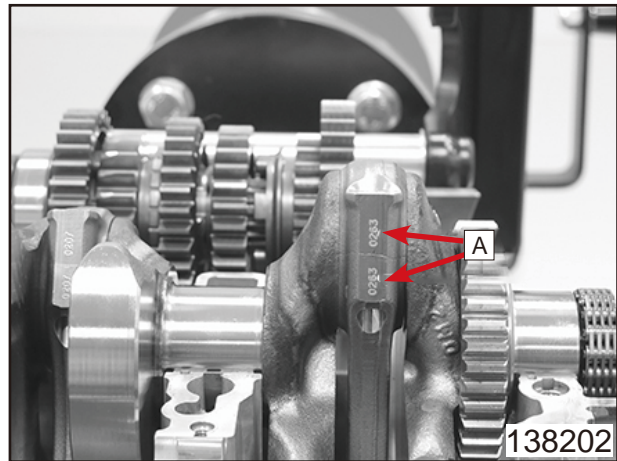
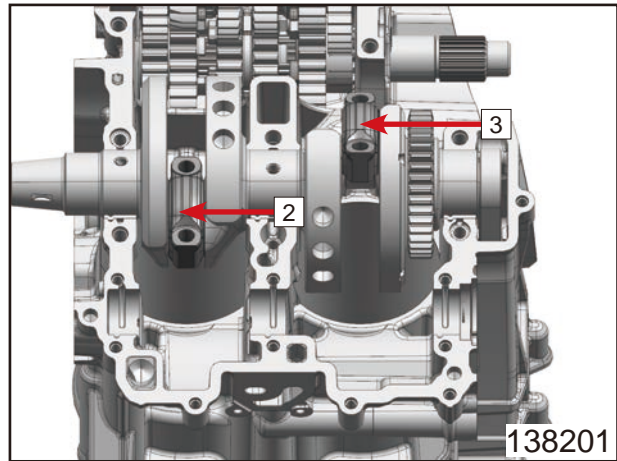

Mount and tighten new screws (4).

## Guideline

Screw, conrod bearing
M8
1st stage
5 N•m
2nd stage
15 N•m
3rd stage
90°
Collar and thread oiled

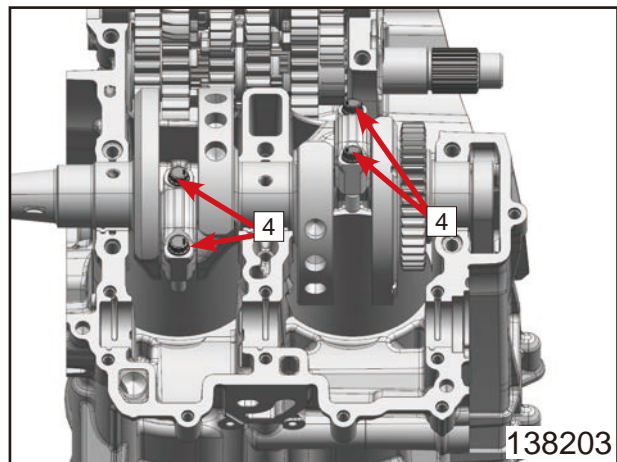

Oil the bearing shells.  
 Position balancer shaft (5) with new greased radial shaft seal ring (6).

Long-life grease
------------------

Align markings (B) and (C).

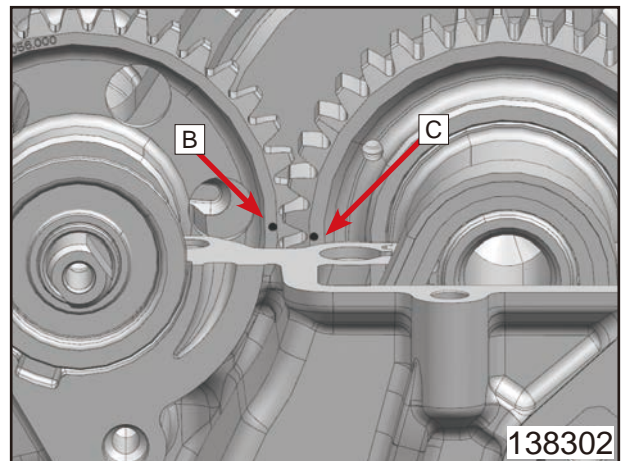
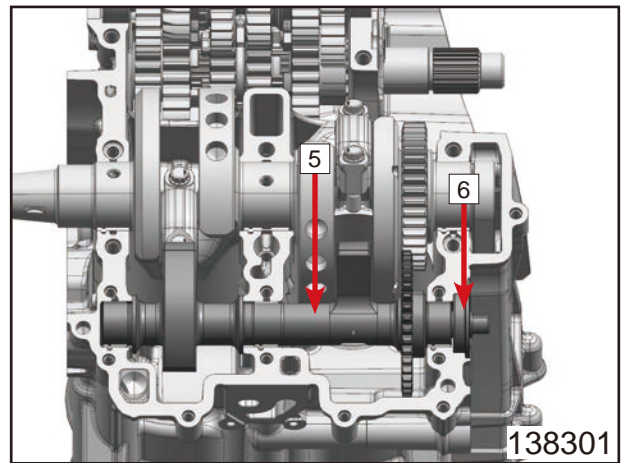

Degrease the sealing surface. Apply sealing compound to the lower section of the engine case.

Loctite® 5910
---------------

**NOTE**

Ensure that the dowels are seated properly.
---

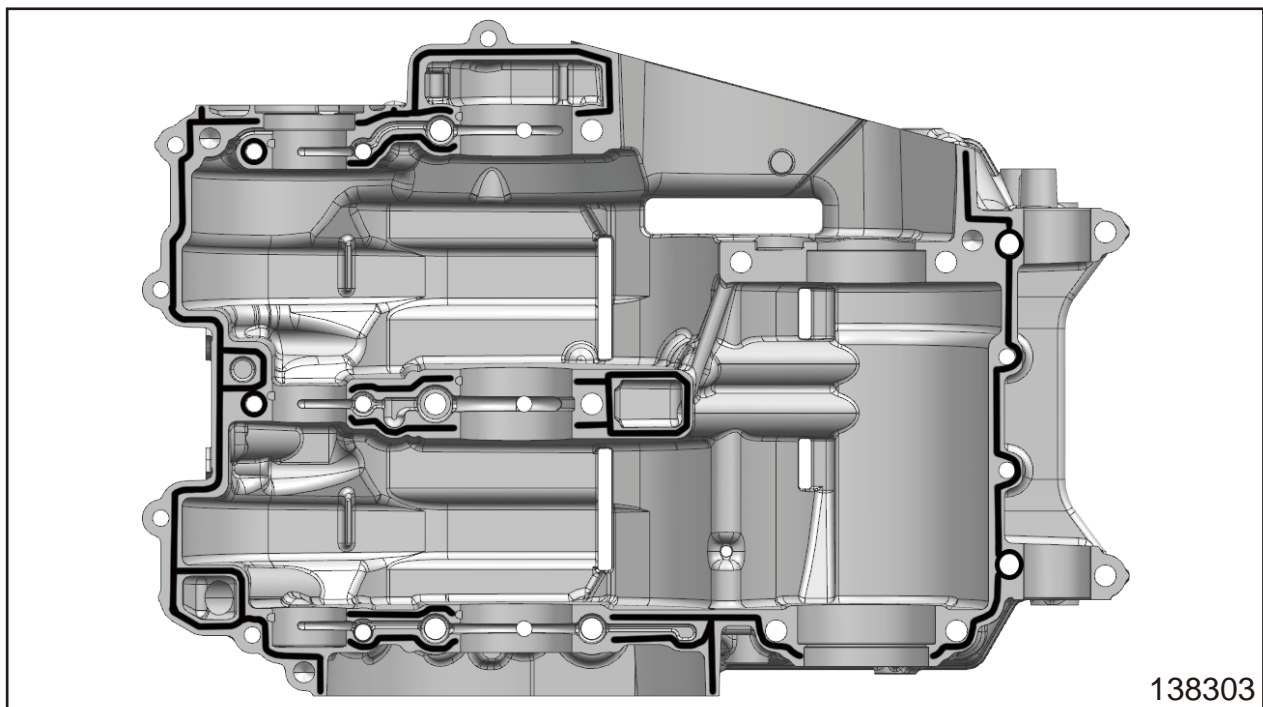

© CFMOTO Powersports, Inc. This manual is subject to all applicable copyright laws. Reproduction or duplication in any form, whole or in part, is strictly prohibited.

# CFMOTO

Mount lower engine case. If necessary, strike lightly again with a rubber mallet.

## NOTE

Do not use the screws to pull the two sections of the engine case together.

Mount screws with washers and tighten in the order (7) to (12).

## Guideline

Screw, engine case
M8x90
25 N•m
Screw support greased

Mount and tighten screws (13).

## Guideline

Screw, engine case
M8x90
25 N•m
Screw support greased

Mount and tighten screws (14).

## Guideline

Screw, engine case
M8x65
25 N•m
Screw support greased

Mount and tighten screws (15).

## Guideline

Screw, engine case
M8x55
25 N•m
Screw support greased

Mount and tighten screw (16).

## Guideline

Screw, engine case
M8x45
25 N•m
Screw support greased

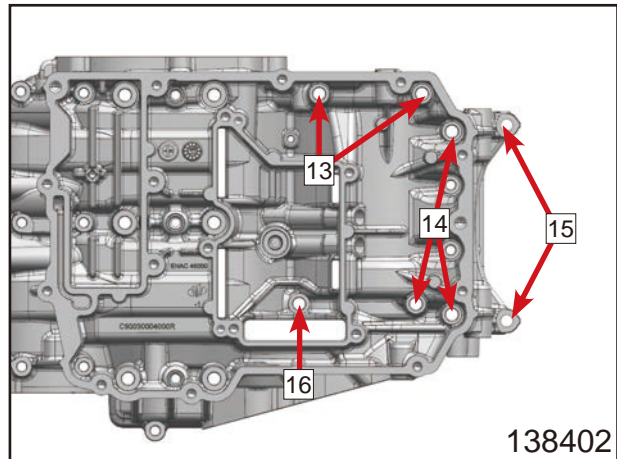
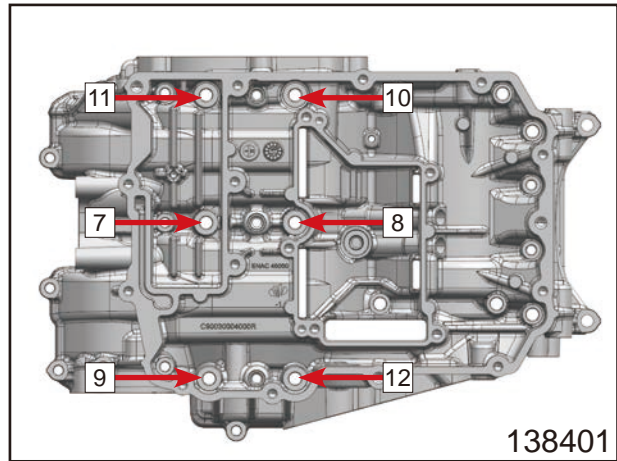

# 13 Engine

Mount and tighten screws (17).

### Guideline

Screw, engine case
M6x60
12 N•m

Mount and tighten screws (18).

### Guideline

Screw, engine case
M6x30
12 N•m

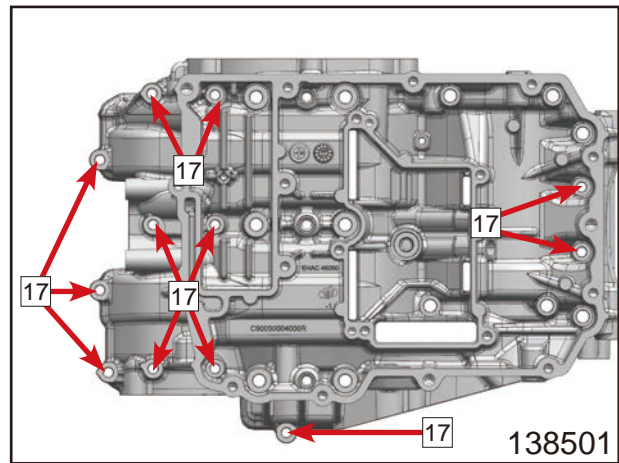

### 13.5.5 Installing the Oil Pump Unit

Mount locating pins (1).

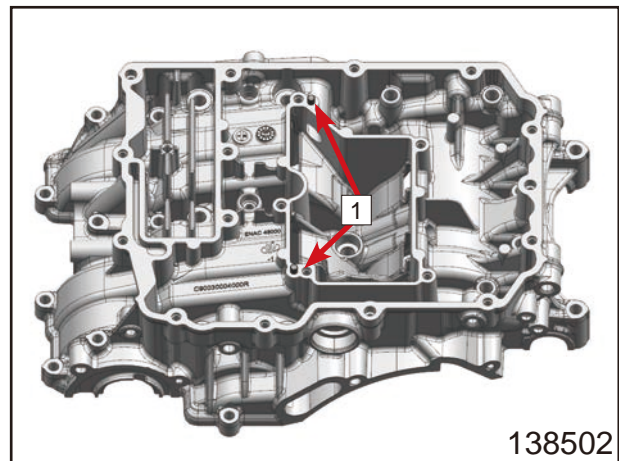

Grease O-rings of the oil pump.

Position oil pump unit (2).

Mount and tighten screws (3).

### Guideline

Screw, oil pump unit
M6
10 N•m

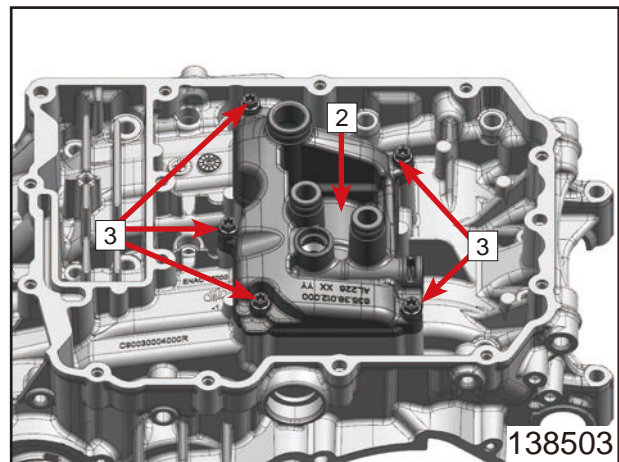

### 13.5.6 Installing the Oil Pan

Grease the new O-rings (1) and mount on the oil line (2).

Mount oil line (2).

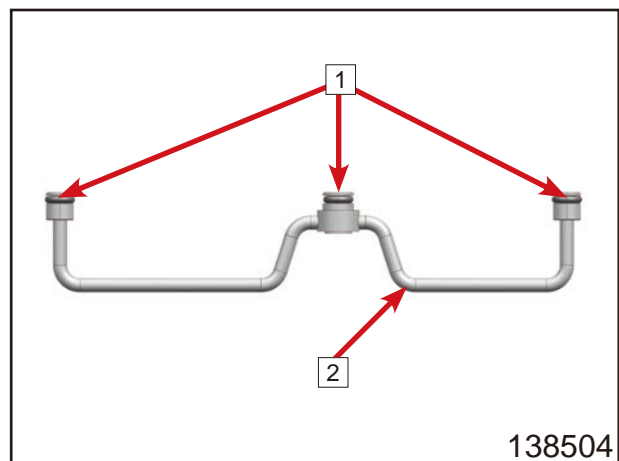

© CFMOTO Powersports, Inc. This manual is subject to all applicable copyright laws. Reproduction or duplication in any form, whole or in part, is strictly prohibited.

# CFMOTO

Position pressure plate (3).  
Mount and tighten screw (4).

**Guideline**

Screw, pressure plate
M5
3 N•m
243 Thread locker

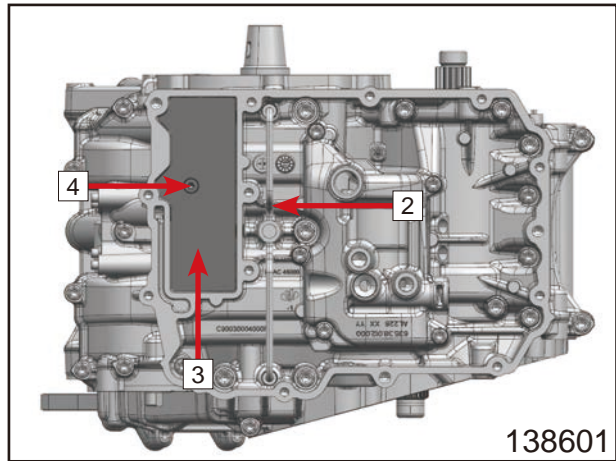

Mount dowels (5).  
Mount gasket (6).

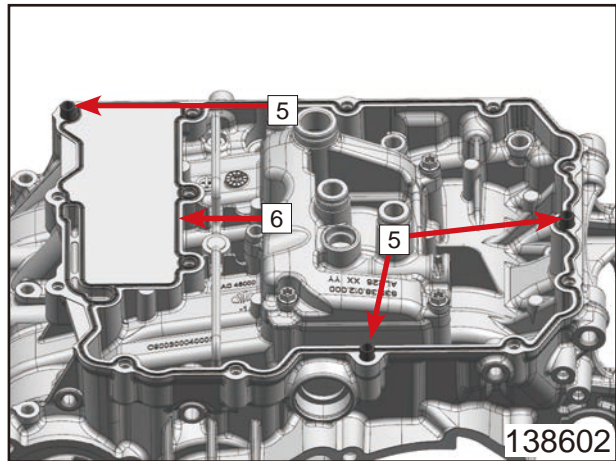

Grease and mount the new O-ring (7).

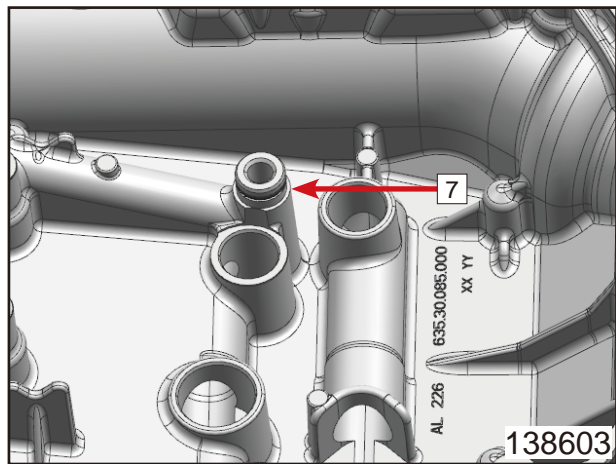

Position oil pan.  
Mount screws (8) but do not tighten yet.

**Guideline**

Screw, oil pan
M6x35
10 N•m

Mount screws (9) and tighten all screws in a crisscross pattern.

**Guideline**

Screw, oil pan
M6x30
10 N•m

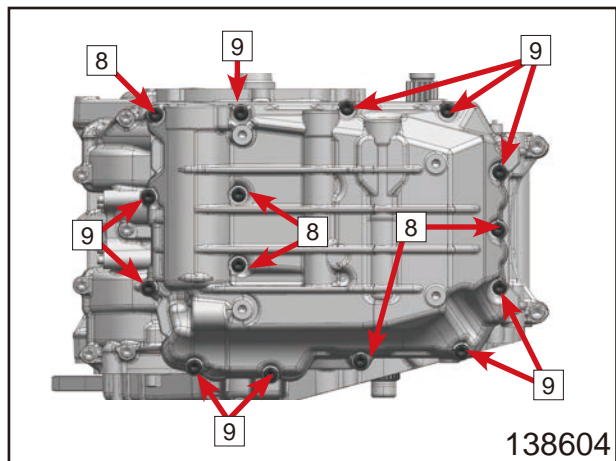

© CFMOTO Powersports, Inc. This manual is subject to all applicable copyright laws. Reproduction or duplication in any form, whole or in part, is strictly prohibited.

## 13.5.7 Installing the Rotor

Position crankshaft to cylinder 1 TDC.  
Remove screw (A) with the washer.  
Mount special tool (B) (locking screw).

Crankshaft Locking Screw  
(See Section 13.1 for details.)

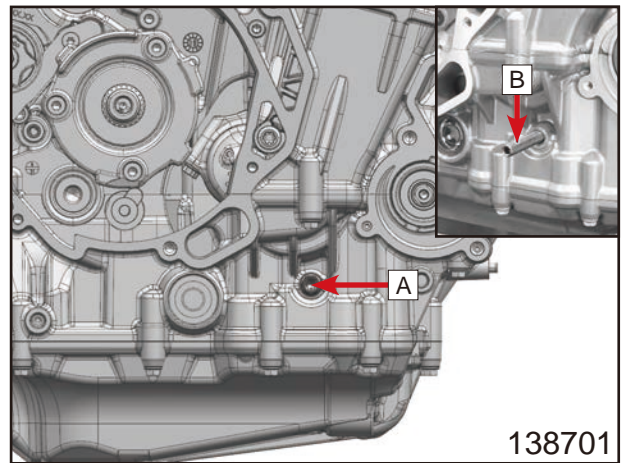

Mount woodruff key (1).

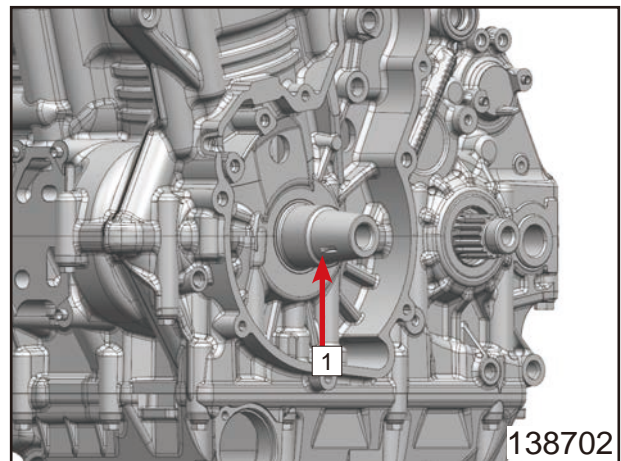

Turn the freewheel gear (2) counterclockwise and mount in the rotor (3).

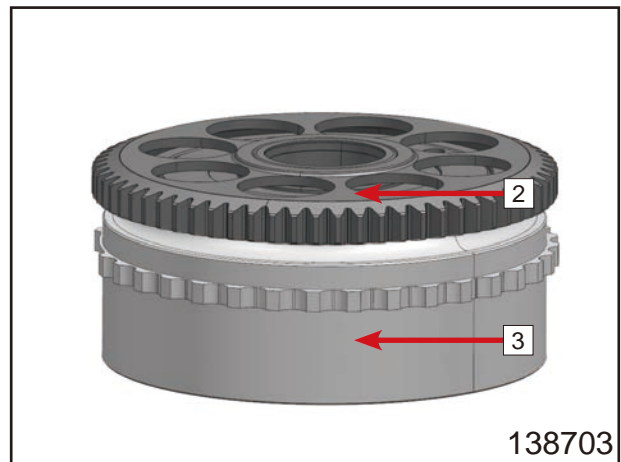

Mount the rotor with the freewheel gear.

### NOTE

Ensure that the woodruff key is seated properly.

Mount and tighten screw (4).

### Guideline

Screw, rotor
M12x1.5
90 N•m
Thread greased

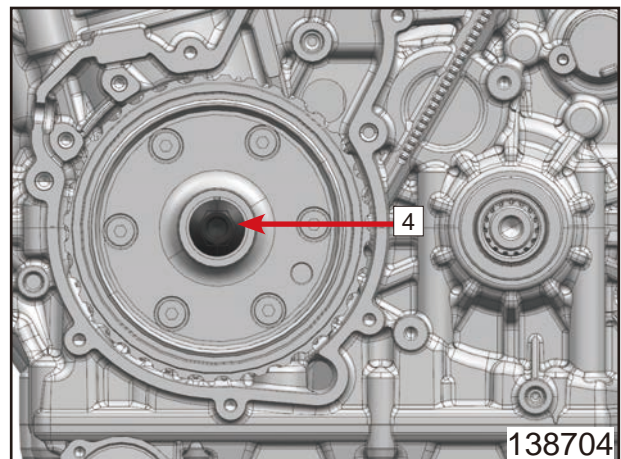

# CFMOTO

## 13.5.8 Installing the Timing Chain Rails

Position tensioning rail (1) with support bushing (2).

Mount and tighten screw (3).

### Guideline

Screw, tensioning rail
M8
15 N•m
243 Thread locker

### NOTE

Ensure that there is no thread locker on the collar of the screw; otherwise, the tensioning rail may lock and break.

Check the tensioning rail for freedom of movement.

Position guide rail (4) from above in the engine case.

Holder (A) engages in the recess (B).

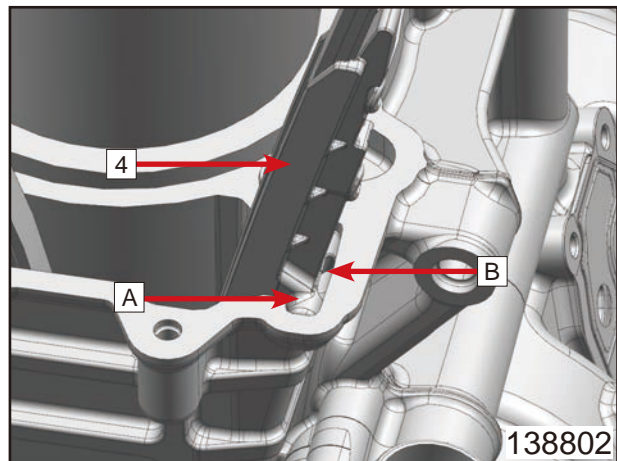
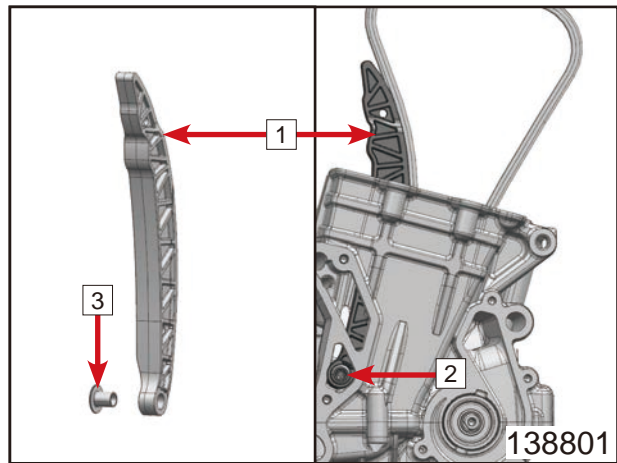

## 13.5.9 Installing the Cylinder Head

Put the new cylinder head gasket in place.

### NOTE

Ensure that the dowels are seated properly.

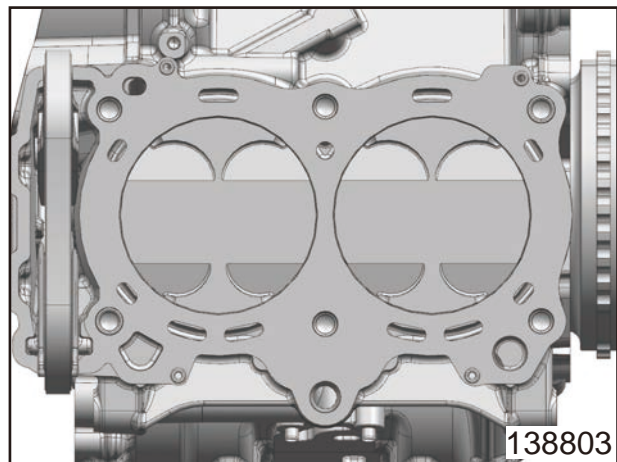

# 13 Engine

Position the cylinder head.

Mount cylinder head screws with washers and tighten step by step in the order from (1) to (6).

## Guideline

Screw, cylinder head	M10x1.25	Tightening sequence: Observe tightening sequence. 1st stage 5 N•m  2nd stage 15 N•m  3rd stage 90°  4th stage 90°  Collar greased / thread oiled
----------------------	----------	--

## NOTE

Always use new cylinder head screws.

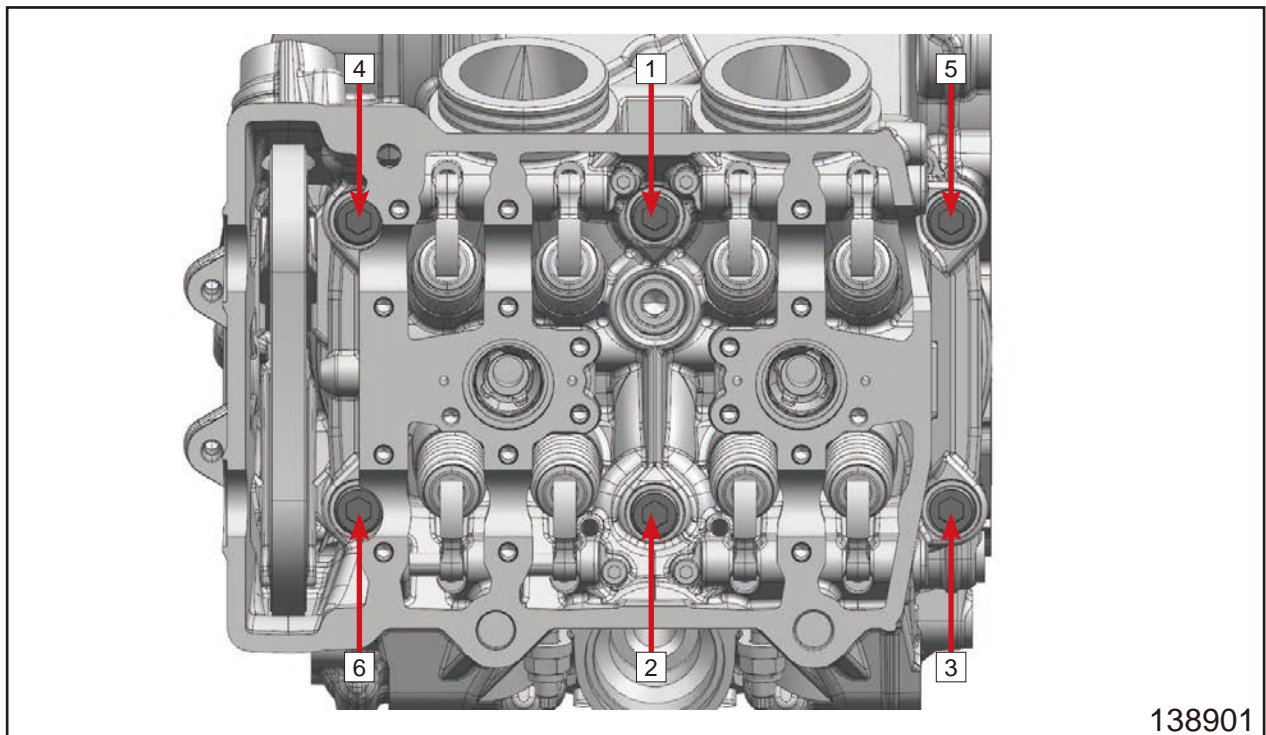

# CFMOTO

Mount and tighten screws (7).

## Guideline

Screw, cylinder head
M6
10 N•m

Mount and tighten screw (8) with gasket.

## Guideline

Screw, timing chain shaft
M6
10 N•m

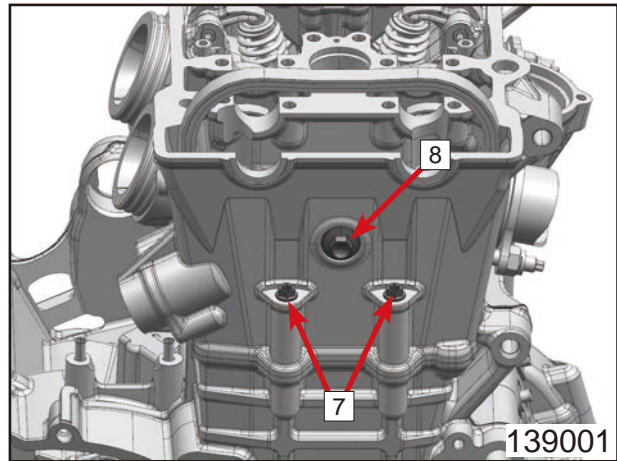

### 13.5.10 Installing the Camshafts

Push exhaust cam lever (1) on cylinder 2 to the side.

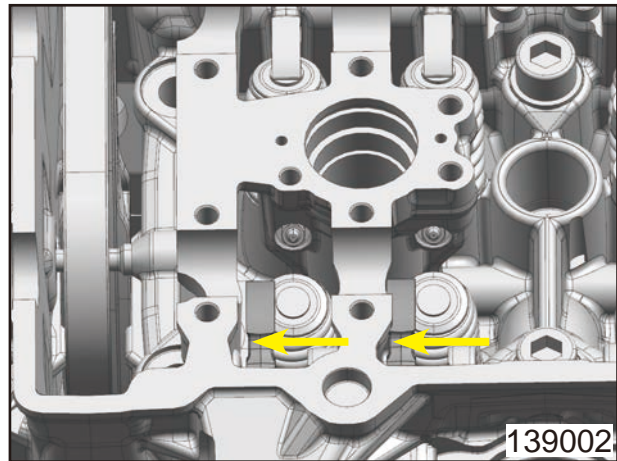

Pull up the timing chain and position the exhaust camshaft (2).

## NOTE

The drive gear wheel for the balancer shaft is located in the exhaust camshaft.

Place timing chain over rear sprocket of the exhaust camshaft and keep taut. The OT1 marking (A) is aligned with the sealing surface.

## NOTE

The OT1 markings are line markings.

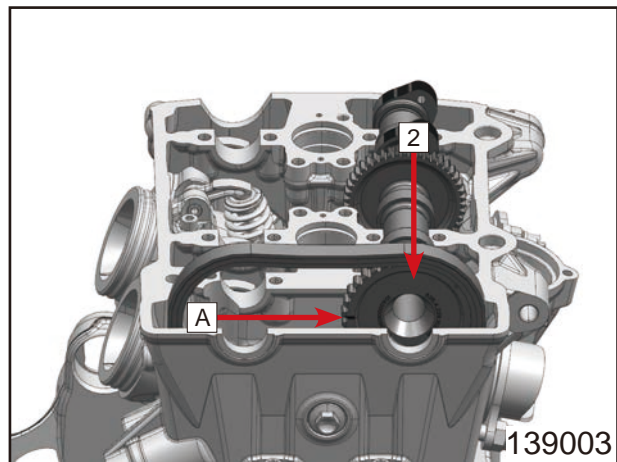

Slip in intake camshaft (3).

**NOTE**

The centrifuge of the engine vent is located on the intake camshaft.

Keep the timing chain taut.

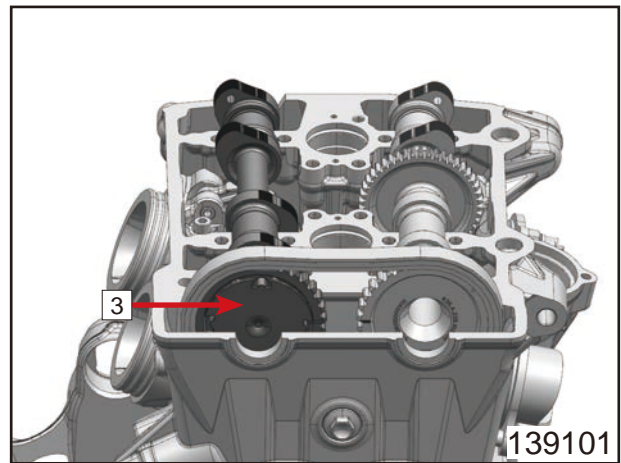

The OT1 markings (A) are aligned with the sealing surface.

**NOTE**

The OT1 markings are line markings.

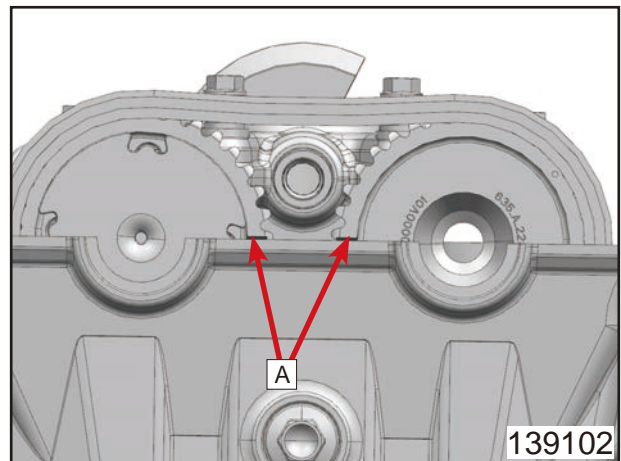

Mount camshaft bearing bridge with balancer shaft (4).

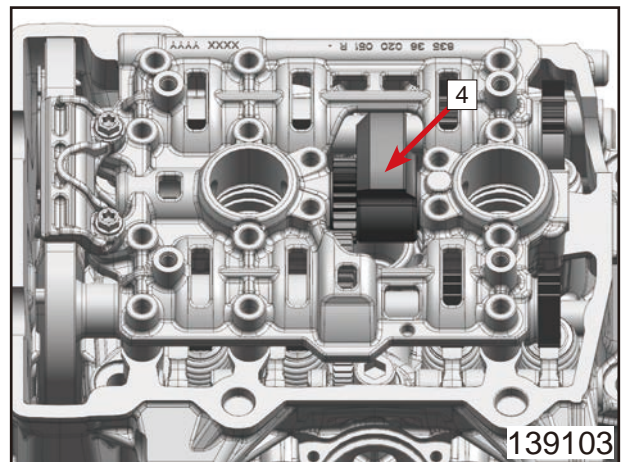

The marking (B) of the balancer shaft is aligned parallel to the sealing surface.

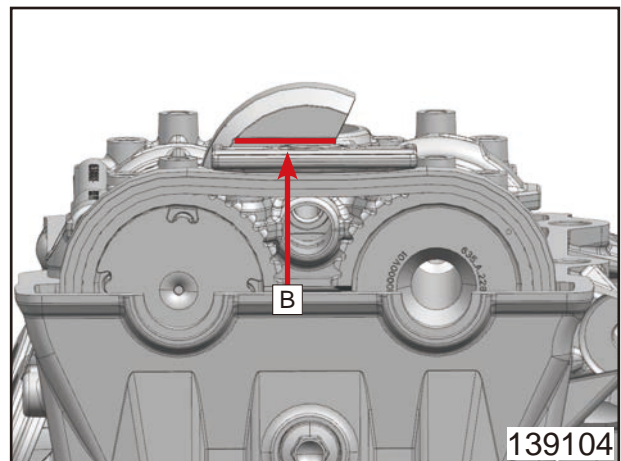

© CFMOTO Powersports, Inc. This manual is subject to all applicable copyright laws. Reproduction or duplication in any form, whole or in part, is strictly prohibited.

# CFMOTO

Mount screws (5) and tighten them from the inside to the outside.

**Guideline**

Screw, camshaft bearing bridge
M6
10 N•m

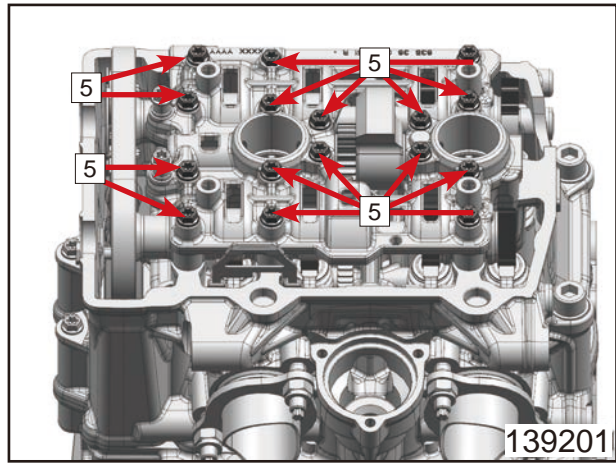

After it has been positioned in the installation location, insert timing chain tensioner (6) with a new O-ring.

Mount and tighten screw plug (7) with new O-ring.

**Guideline**

Plug, timing chain tensioner
M24x1.5
25 N•m

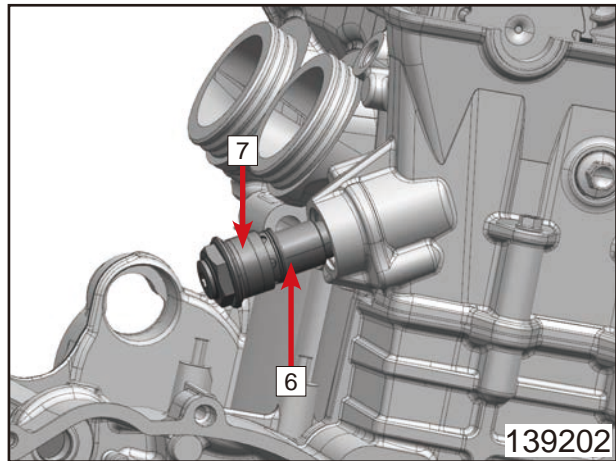

Remove screw (8) with the O-ring and use a special tool (Release device for timing chain tensioner ) (A) to push the timing chain tensioner toward the timing chain.

Release Device for Timing Chain Tensioner (See Section 13.1 for details. )

The timing chain tensioner unlocks. Mount and tighten screw (8) with the O-ring.

**Guideline**

Screw, unlocking of timing chain tensioner
M10x1
10 N•m

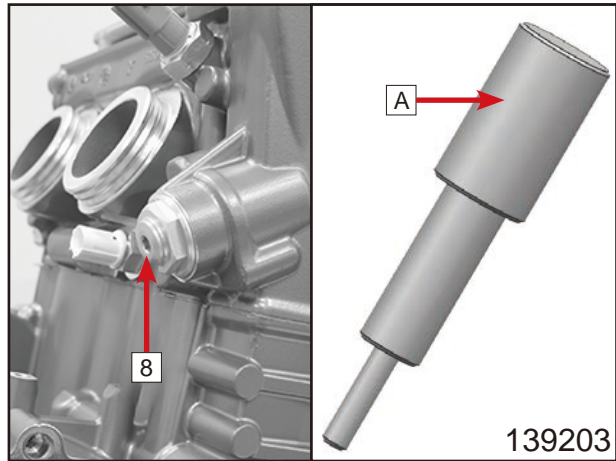

Remove the special tool (Locking screw).

Crankshaft Locking Screw (See Section 13.1 for details.)

Crank the engine several times. Turn the crankshaft counterclockwise to ignition top dead center of cylinder 1 and lock it using special tool (Locking screw).

Crankshaft Locking Screw (See Section 13.1 for details.)

Check position of the camshafts with special tool.

TIMING CAMSHAFT TESTING TOOL (See Section 13.1 for details.)

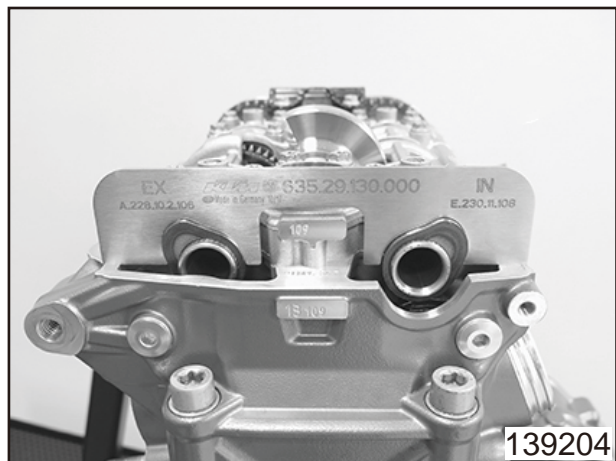

© CFMOTO Powersports, Inc. This manual is subject to all applicable copyright laws. Reproduction or duplication in any form, whole or in part, is strictly prohibited.

Check position of the balancer shaft with special tool.

**BALANCER SHAFT ALIGNMENT TESTING TOOL**  
(See Section 13.1 for details.)

The marking (C) of the balancer shaft is located in the (D) area of the adjusting gauge.

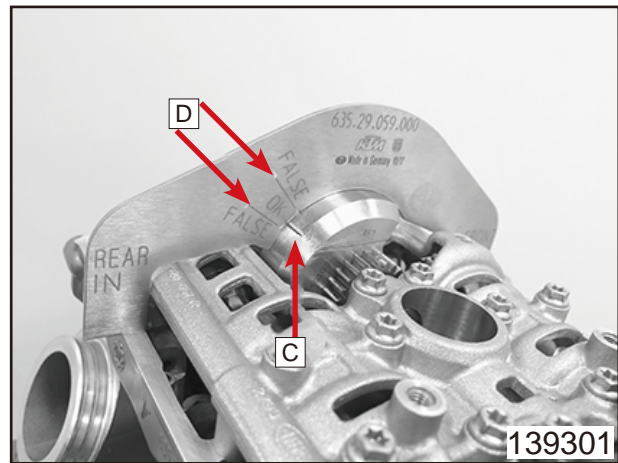

Remove special tool (A) (Locking screw).

**Crankshaft Locking Screw**  
(See Section 13.1 for details.)

Mount and tighten screw (9) with the washer.

**Guideline**

Screw plug, locking screw
M8
15 N•m

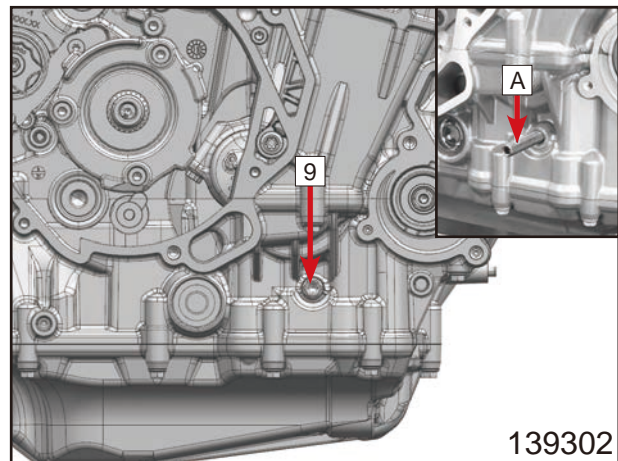

Turn the crankshaft counterclockwise by the specified value and set it to ignition top dead center of cylinder 2.

**Guideline**

435°

The OT2 markings (E) are aligned with the sealing surface.

**NOTE**  
The OT2 markings are dot markings.

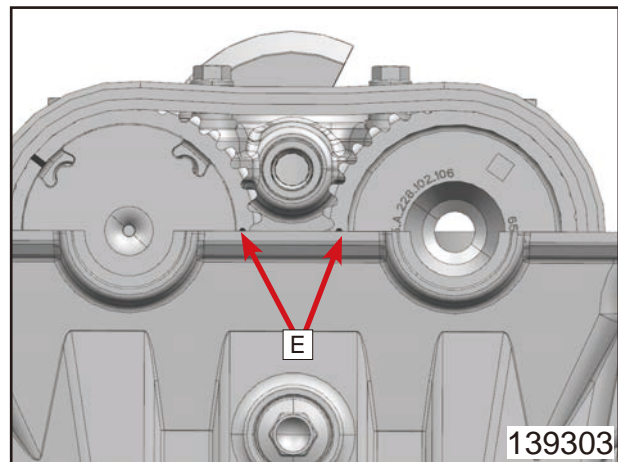

Position exhaust cam lever (1) on cylinder 2.

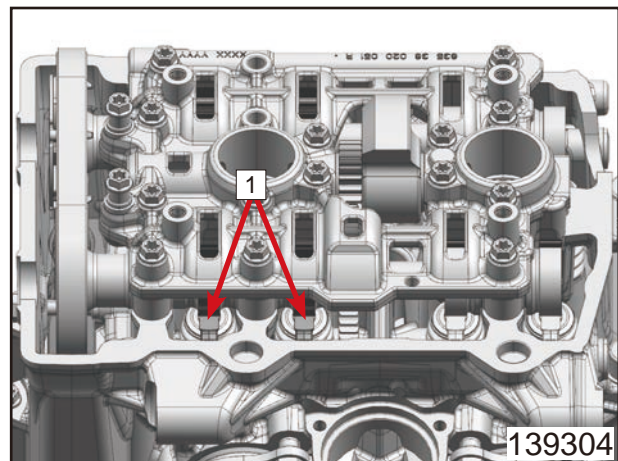

© CFMOTO Powersports, Inc. This manual is subject to all applicable copyright laws. Reproduction or duplication in any form, whole or in part, is strictly prohibited.

Mount cam lever clip (13).

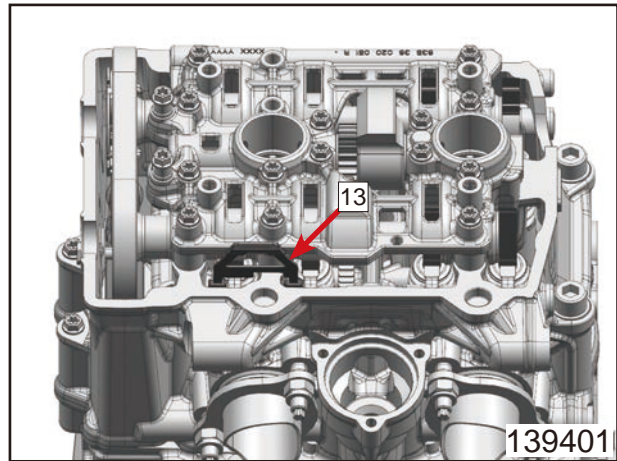

### 13.5.11 Checking the Valve Clearance

Crank the engine several times.

Turn the crankshaft counterclockwise and set it to ignition top dead center of cylinder 1.

The OT1 markings (A) are aligned with the sealing surface.

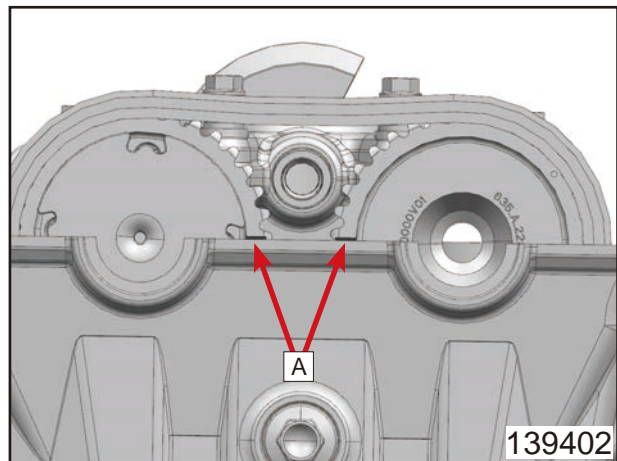

**NOTE**

The OT1 markings are line markings.

Check the valve clearance at the exhaust valves and the intake valves between the camshaft and cam lever using a feeler gauge (1).

**Guideline**

Valve play, cold
Intake at: 20 °C 0.10mm~0.15 mm
Exhaust at: 20 °C 0.15mm~0.20 mm

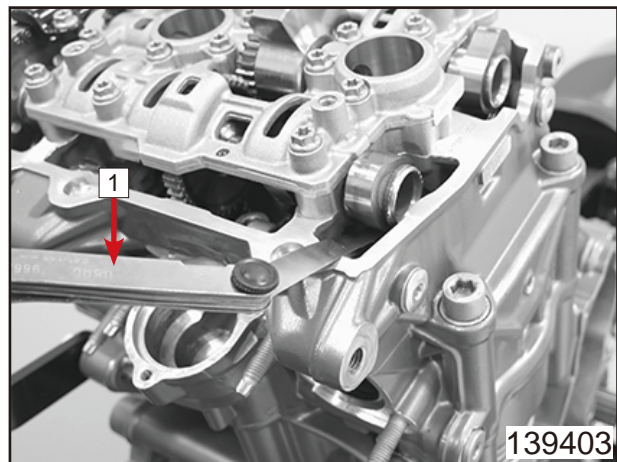

If the valve clearance does not meet specifications:

Adjust the valve clearance.

Turn the crankshaft counterclockwise by the specified value and set it to ignition top dead center of cylinder 2.

**Guideline**

435°

The OT2 markings (B) are aligned with the sealing surface.

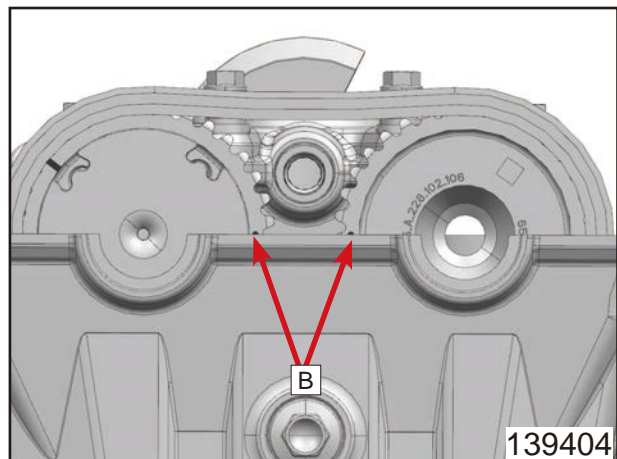

**NOTE**

The OT2 markings are dot markings.

Remove cam lever clip (2).

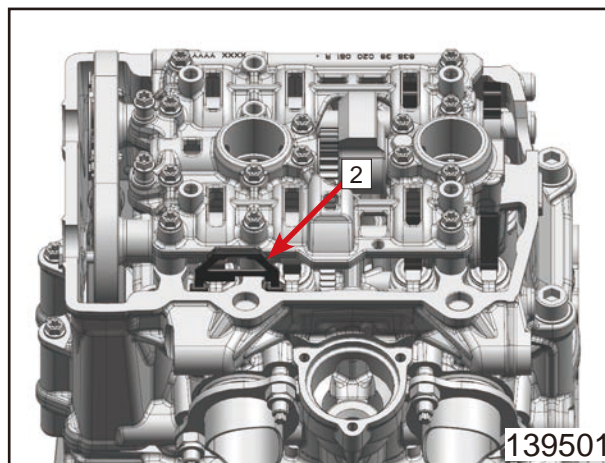

Check the valve clearance at the exhaust valves and the intake valves between the camshaft and cam lever using a feeler gauge (1).

**Guideline**

Valve play, cold
Intake at: 20 °C 0.10mm~0.15 mm
Exhaust at: 20 °C 0.15mm~ 0.20 mm

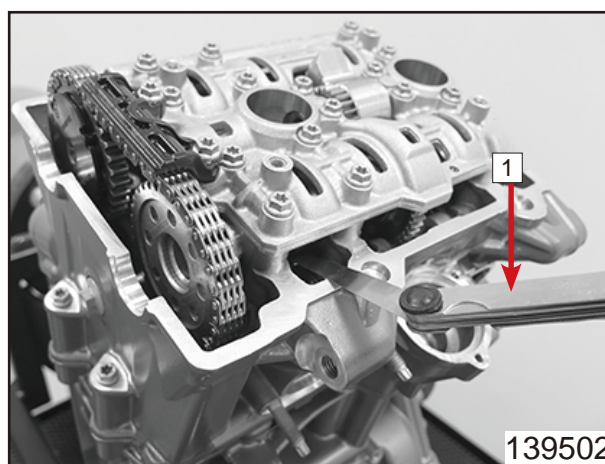

If the valve clearance does not meet specifications:  
Adjust the valve clearance.

**13.5.12 Adjusting the Valve Clearance and Cleaning the Oil Screen**

**Preparatory work**

Remove the camshafts.

**Main Work**

- Swing up cam lever (1).
- Remove shims (2) and set them down according to the installation position.
- Correct the shims based on the results of the valve clearance check.
- Insert suitable shims.
- Clean oil screen (3).
- Install the camshafts.
- Check the valve clearance.

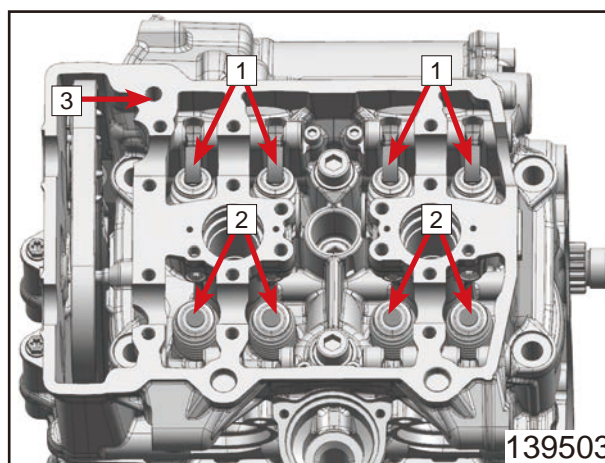

© CFMOTO Powersports, Inc. This manual is subject to all applicable copyright laws. Reproduction or duplication in any form, whole or in part, is strictly prohibited.

## 13.5.13 Installing the Spark Plugs

Mount and tighten the spark plugs.

### Guideline

Spark plug
M10
11 N•m

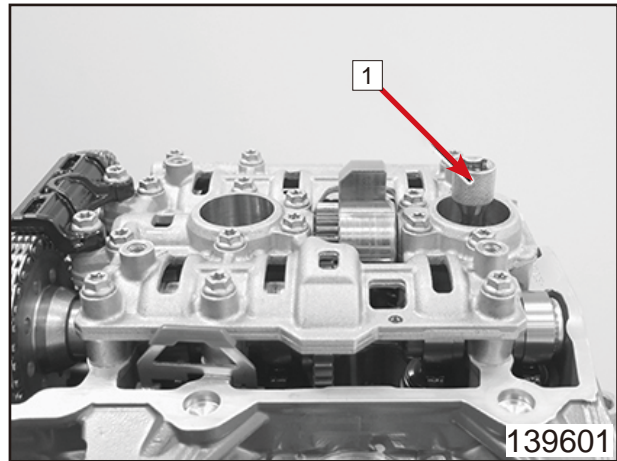

Grease the O-rings and mount spark plug shaft inserts (2) with gasket.

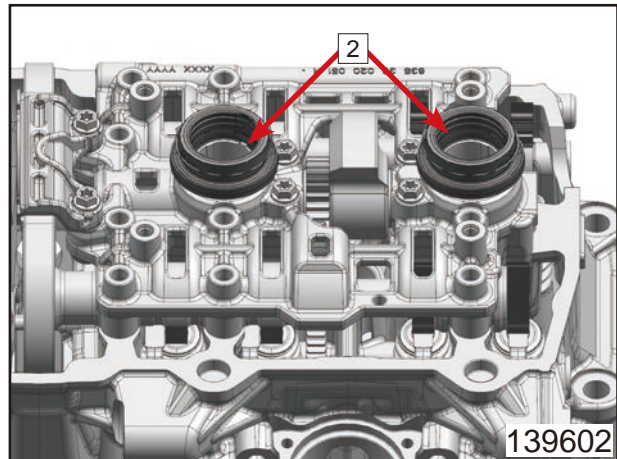

## 13.5.14 Installing the Shift Shaft

Slide shift shaft (1) with the washer into the bearing seat.

Push sliding plate (2) away from shift drum locating unit (3). Insert the shift shaft all the way.

### NOTE

The neutral position (A) must be aligned with the sliding plate (2) for assembly.

Let the sliding plate engage in the shift drum locating unit.

Shift through the transmission.

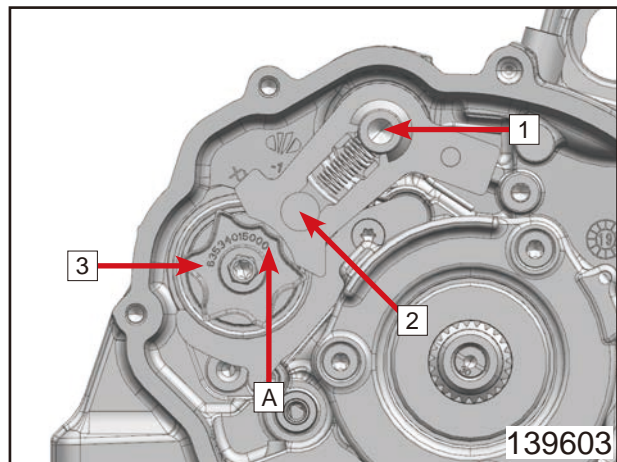

Position retaining bracket (4) in the groove (B).

Mount and tighten screw (5).

### Guideline

Screw, shift shaft retaining bracket
M6
10 N•m
243 Thread locker

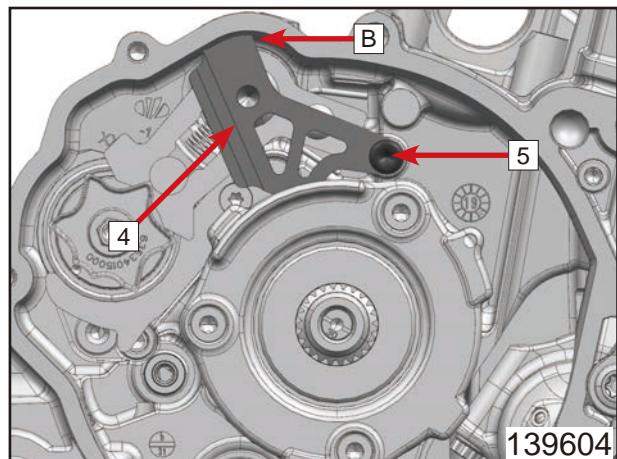

## 13.5.15 Installing the Locking Lever

Position locking lever (1) with sleeve (2) and spring (3).  
Mount and tighten screw (4).

### Guideline

Screw, locking lever
M6
10 N•m
243 Thread locker

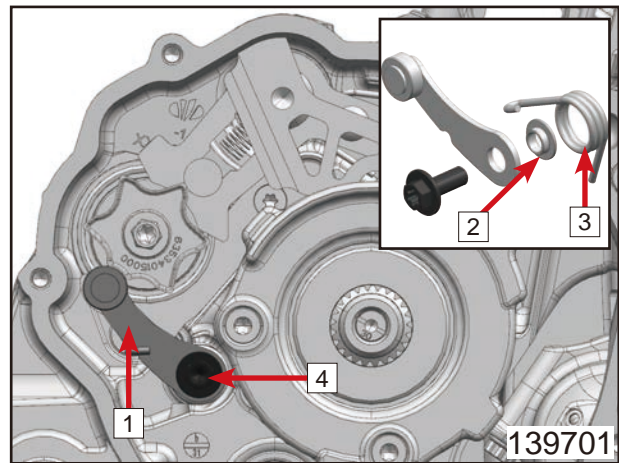

## 13.5.16 Installing the Clutch Basket

Oil collar bushing (1) thoroughly.  
Position collar bushing (1) with oil pump idler gear (2).

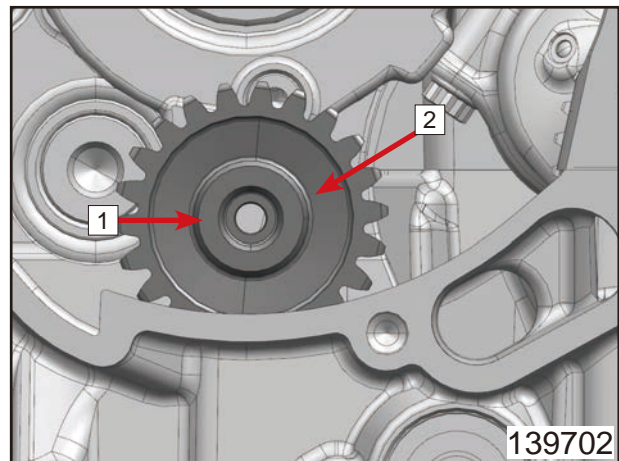

Mount and tighten screw (3).

### Guideline

Screw ,oil pump idler gear
M8
15 N•m
243 Thread locker

### NOTE

The screw (3) must always be replaced.

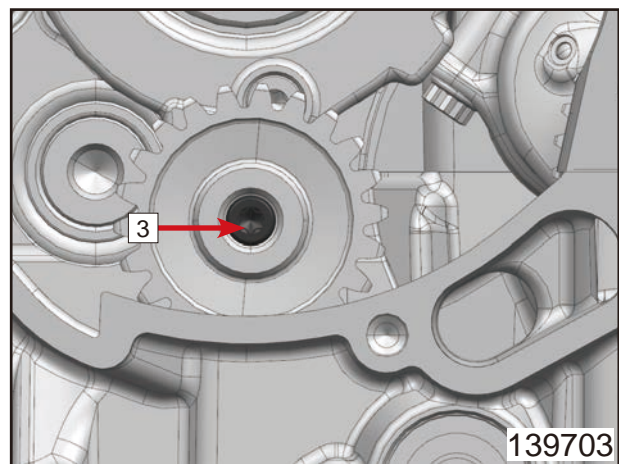

Mount washer (4).

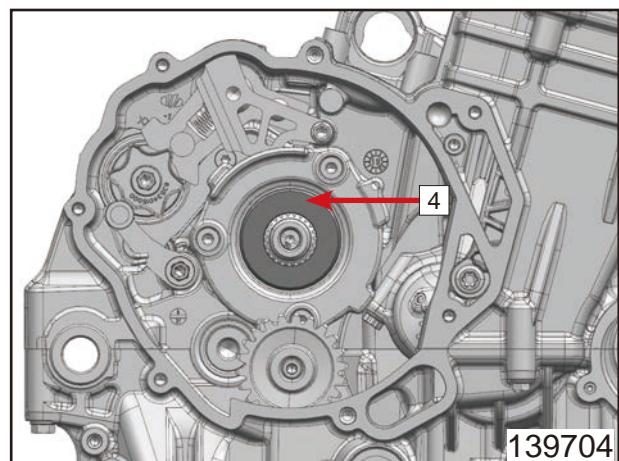

# CFMOTO

Position the clutch basket (5).

**NOTE**

Turn the clutch basket and oil pump idler gear backwards and forwards slightly to help them mesh more easily.

Mount needle bearing (6).

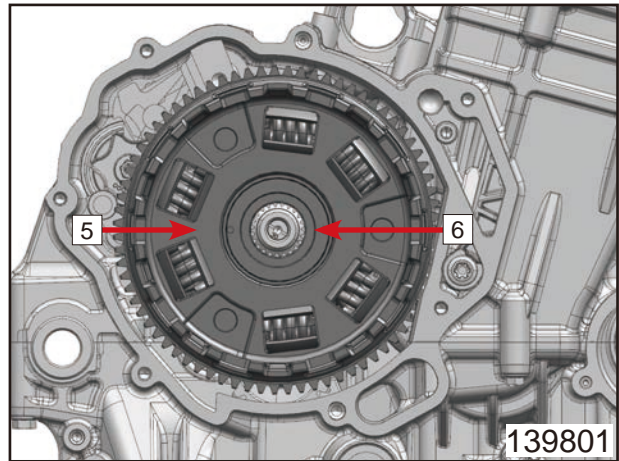

Mount washer (7) and inner clutch hub (8).

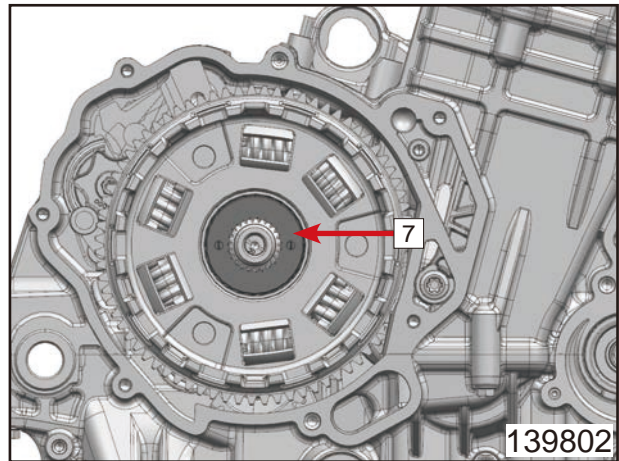

Mount nut (9) with the washer.  
 Lock crankshaft with crankshaft locking screw. (Refer to Section 13.3.20.)  
 Use a special tool (A) (Clutch stop tool) to hold the inner clutch hub (8) and tighten the nut (9).

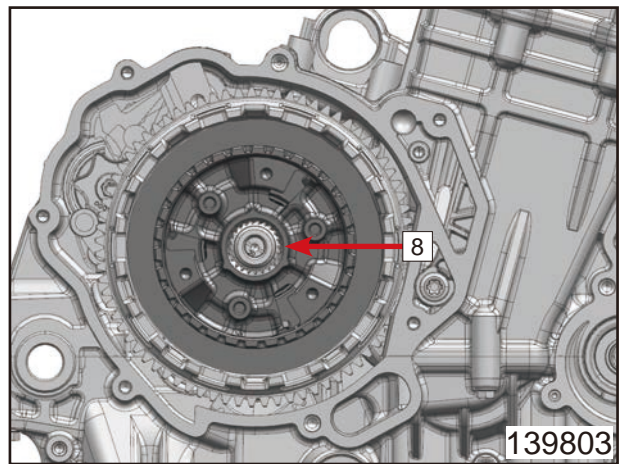

Clutch Stop Tool  
 (See Section 13.1 for details.)

**Guideline**

Nut, inner clutch hub
M20×1.5
120 N•m
243 Thread locker

Remove the clutch stop tool (A).  
 Remove crankshaft locking screw. (Refer to Section 13.3.23.)

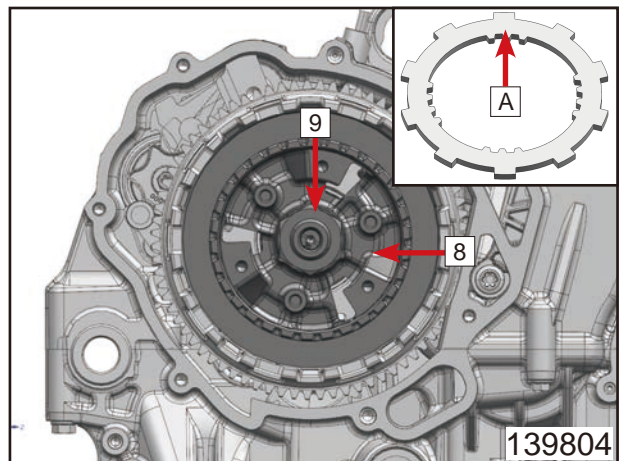

© CFMOTO Powersports, Inc. This manual is subject to all applicable copyright laws. Reproduction or duplication in any form, whole or in part, is strictly prohibited.

## 13.5.17 Installing the Clutch Discs

Mount support ring (1) and pretension ring (2).

The pretension ring rests against the support ring on the inside and the outside faces away from the support ring.

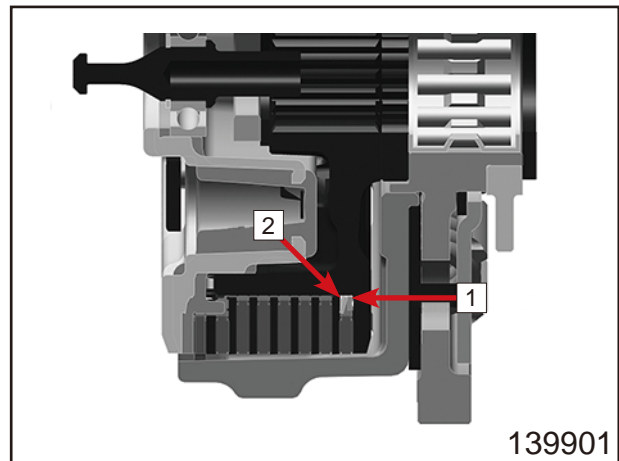

Thoroughly oil the clutch facing discs.

Mount a clutch facing disc (3) with a larger inside diameter.

Alternately mount 6 intermediate clutch discs (4) and 5 of the same clutch facing discs (5).

Alternately mount 2 clutch facing discs (3) and an intermediate clutch disc (6) with a larger inside diameter.

The outer clutch facing disc must be mounted offset by one mesh.

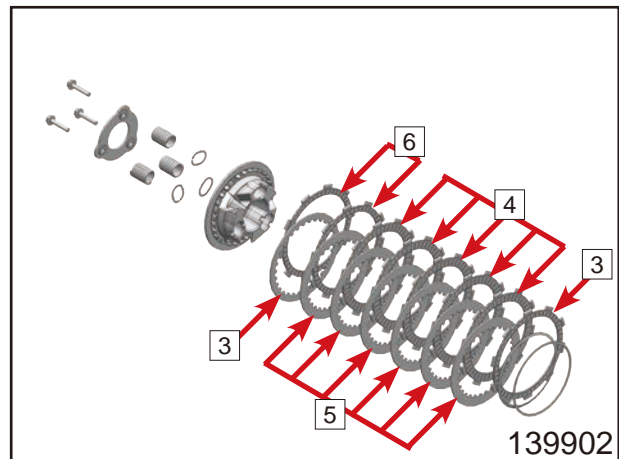

Position clutch pressure cap (7).

The gear teeth of the outer intermediate clutch disc engage in the clutch pressure cap.

The clutch pressure cap rests flush against the outer clutch facing disc.

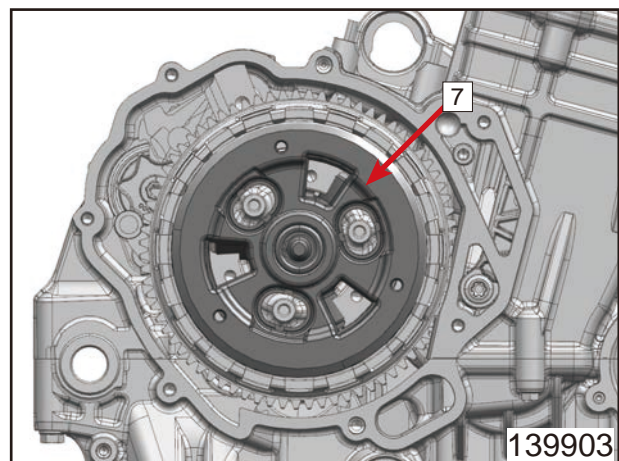

Position clutch center (8) and the springs.

Mount and tighten screws (9).

### Guideline

Screw, clutch spring
M6
10 N•m

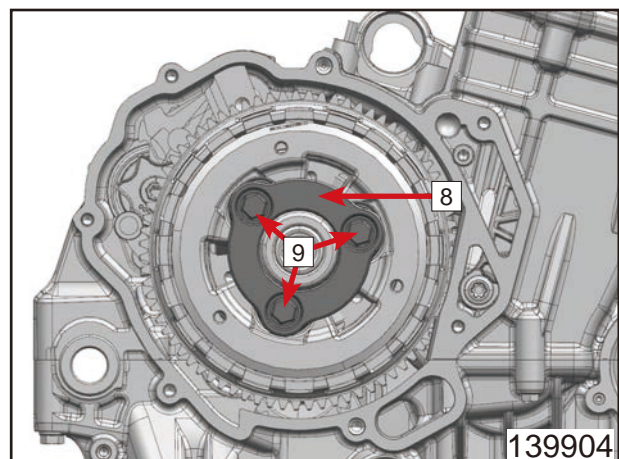

## 13.5.18 Installing the Clutch Cover

Mount dowels (1).

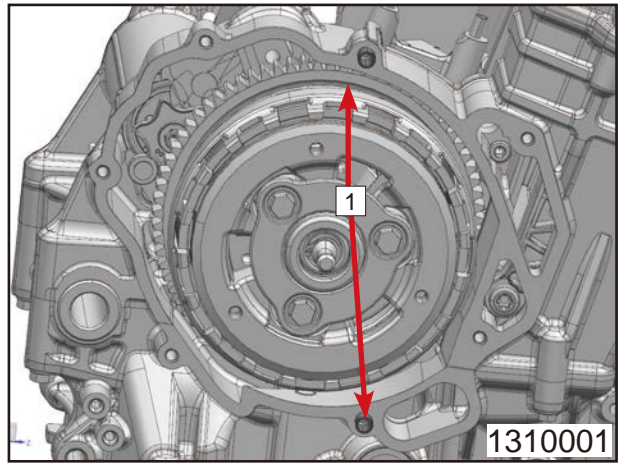

Position the clutch cover with the clutch cover gasket.

Clutch push rod (A) engages in groove (B).

**NOTE**

Swivel clutch release lever counterclockwise.

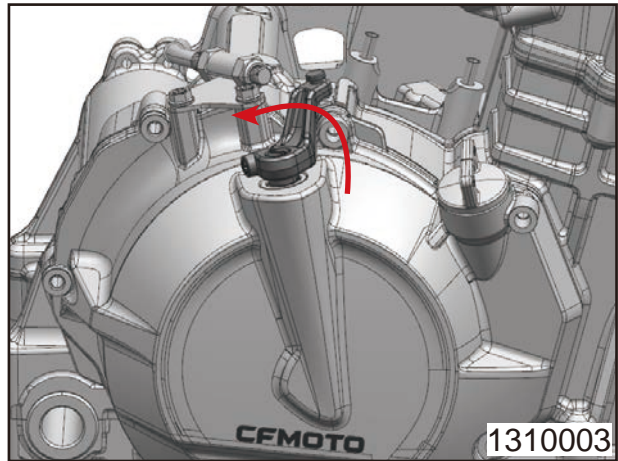
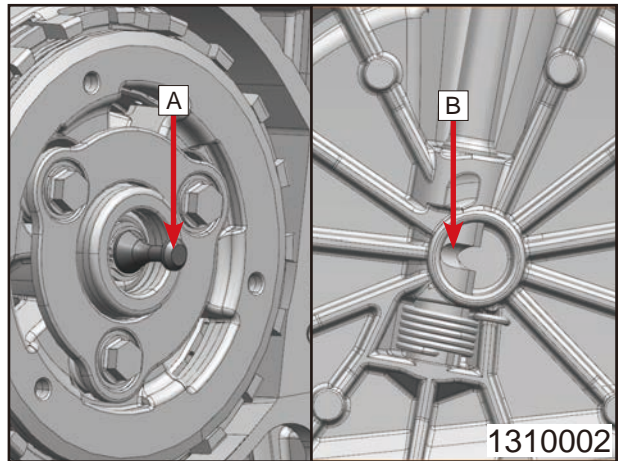

Mount screws (2), but do not tighten yet.

**Guideline**

Screw, clutch cover
M6x30
10 N•m

Mount screws (3), but do not tighten yet.

**Guideline**

Screw, clutch cover
M6x25
10 N•m

Mount screw (4) and tighten all screws in a crisscross pattern.

**Guideline**

Screw, clutch cover
M6x35
10 N•m

### 13.5.19 Mounting the Water Pump Cover

Mount form washer (1).

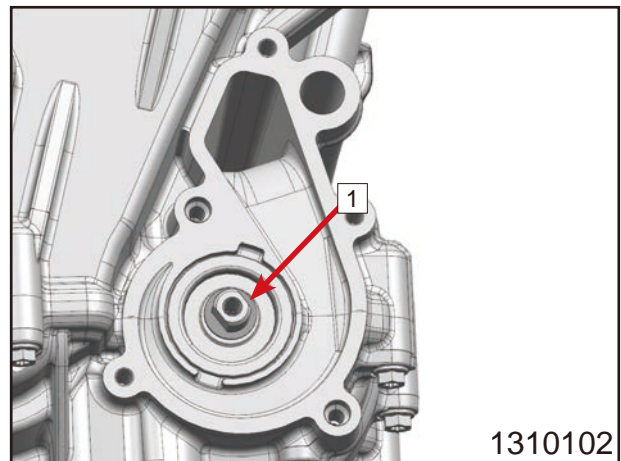
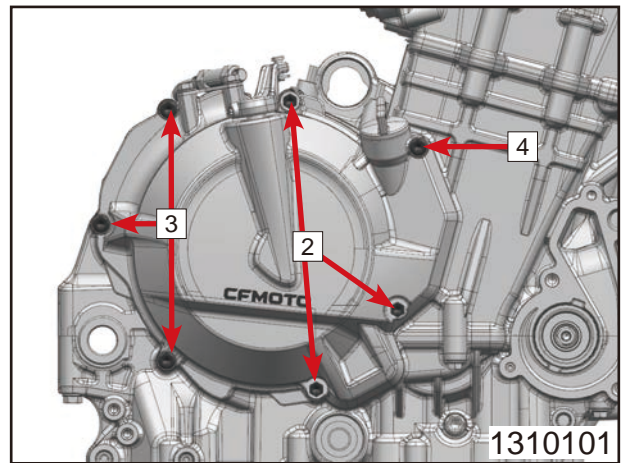

Mount water pump impeller (2).

Mount and tighten screw (3).

**Guideline**

Screw, water pump wheel
M6
10 N•m
243 Thread locker

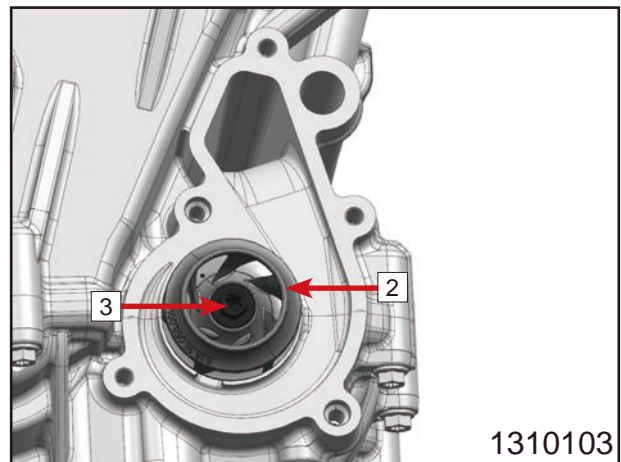

Mount dowels (4).

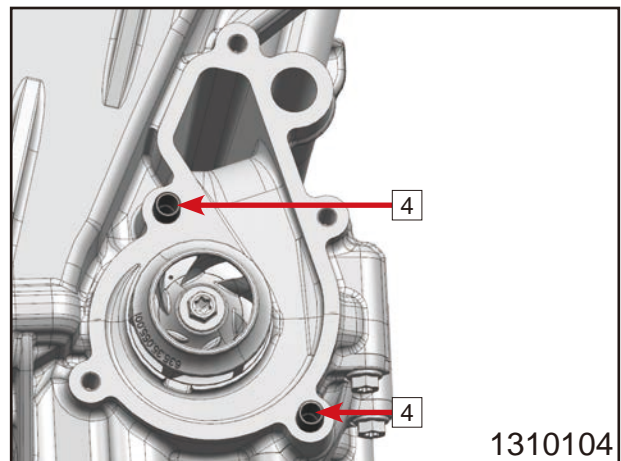

© CFMOTO Powersports, Inc. This manual is subject to all applicable copyright laws. Reproduction or duplication in any form, whole or in part, is strictly prohibited.

Position water pump cover with the gasket.  
Mount and tighten screws (5).

**Guideline**

Screw, water pump cover
M6
10 N•m
243 Thread locker

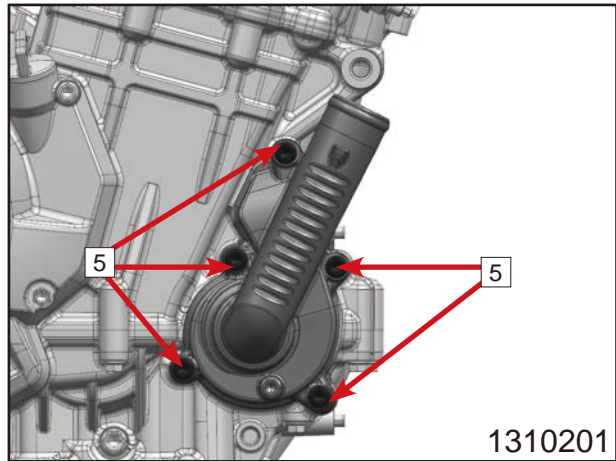

**13.5.20 Installing the Thermostat**

Position thermostat (1) with the gasket.  
Drill hole (A) must face upward.

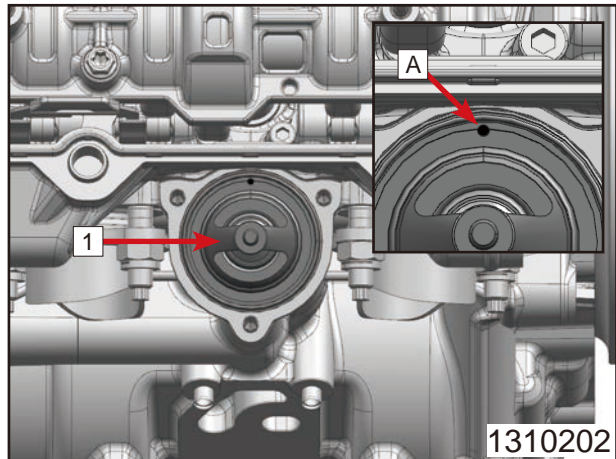

Position the thermostat case.  
Mount and tighten screws (2).

**Guideline**

Screw, thermostat case
M5
6 N•m
243 Thread locker

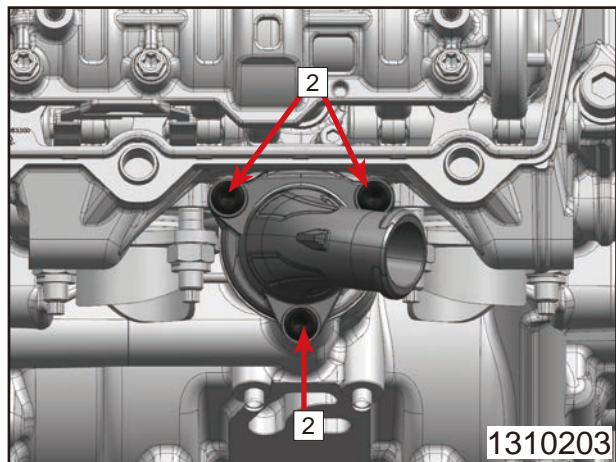

**13.5.21 Installing the Heat**

Position gasket (1).  
The **OUTSIDE** marking (A) is legible.

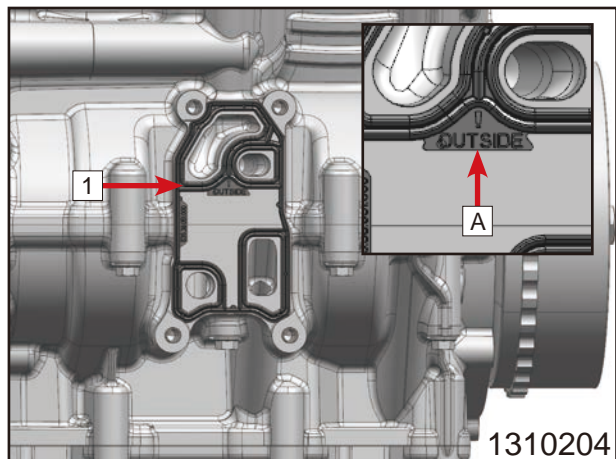

© CFMOTO Powersports, Inc. This manual is subject to all applicable copyright laws. Reproduction or duplication in any form, whole or in part, is strictly prohibited.

Position heat exchanger (2).  
Mount and tighten screws (3).

### Guideline

Screw, heat exchanger
M6
10 N•m
243 Thread locker

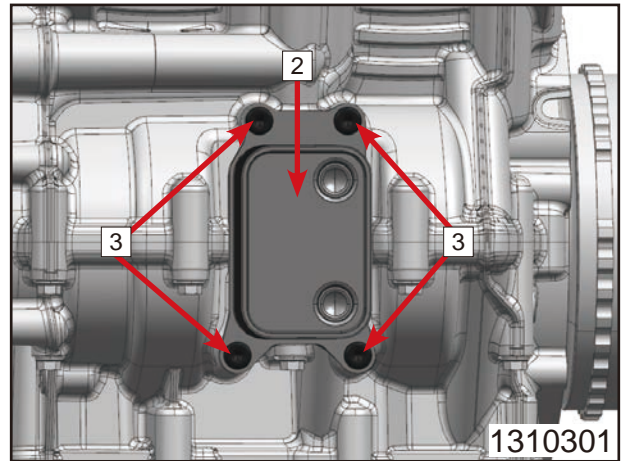

### 13.5.22 Installing the Crankshaft Speed Sensor

Position the crankshaft speed sensor.  
Mount and tighten screws (1).

### Guideline

Screw, crankshaft speed sensor
M5
6 N•m
243 Thread locker

Position the cable and position rubber grommet (2) in the engine case.

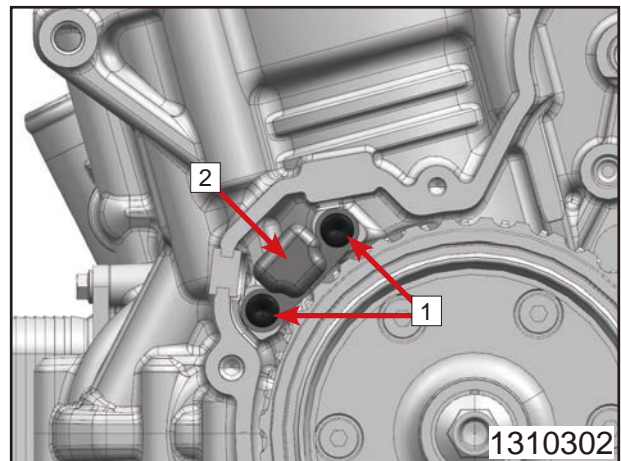

### 13.5.23 Installing the Torque Limiter and the Starter Intermediate Gear

Mount shaft (1) and starter intermediate gear (2) with the needle bearing and the washers.

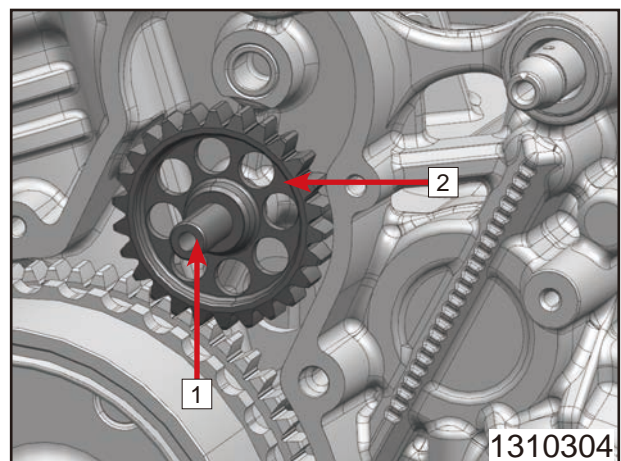
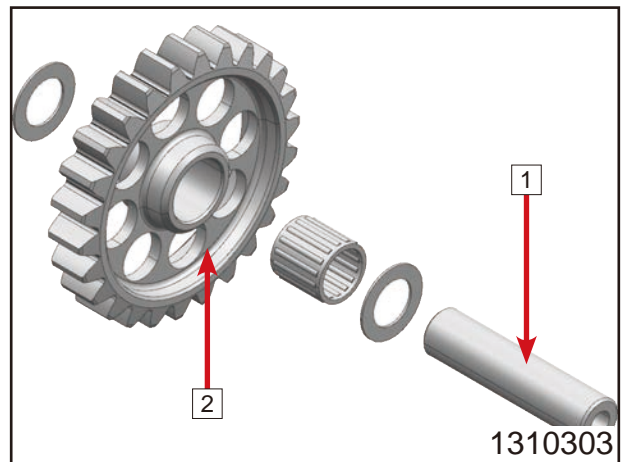

Mount torque limiter (3) with the rear washer.

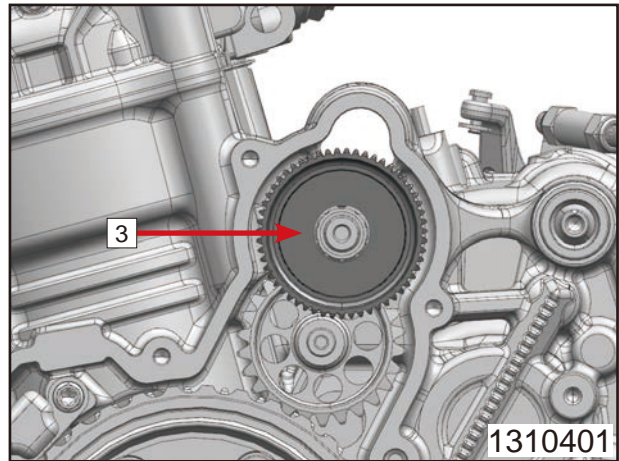

### 13.5.24 Installing the Alternator Cover

Apply sealing compound lightly in the area of the rubber grommet.

Loctite® 5910
---------------

Mount dowels (1) and put alternator cover gasket (2) in place.

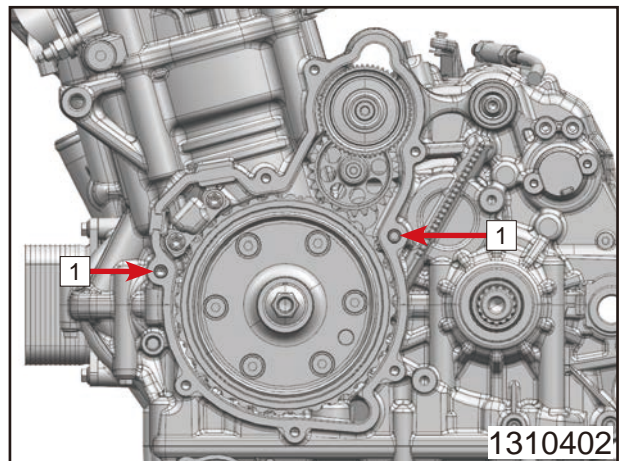

Position the alternator cover.  
Mount and tighten screws (3).

#### Guideline

Screw, alternator cover
M6x30
10 N•m

Mount and tighten screws (4).

#### Guideline

Screw, alternator cover
M6x35
10 N•m

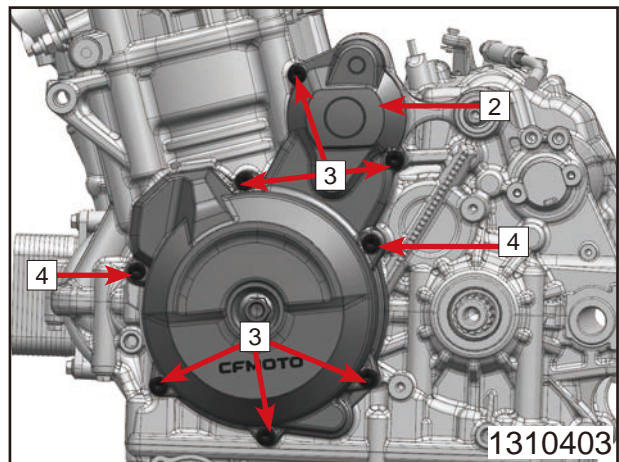

Mount and tighten screw plug (5) with the O-ring.

#### Guideline

Screw plug, alternator cover
M24x1.5
8 N•m

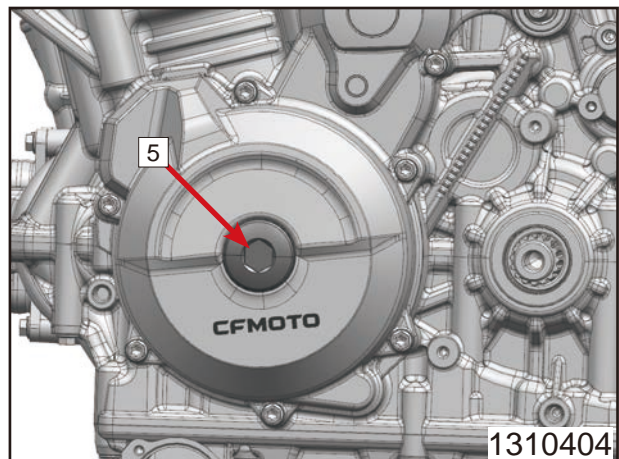

## 13.5.25 Installing the Spacer

Before mounting, grease spacer (1) in area (A) and O-ring (2).

Long-life grease
------------------

Position the O-ring in the recess of the spacer.

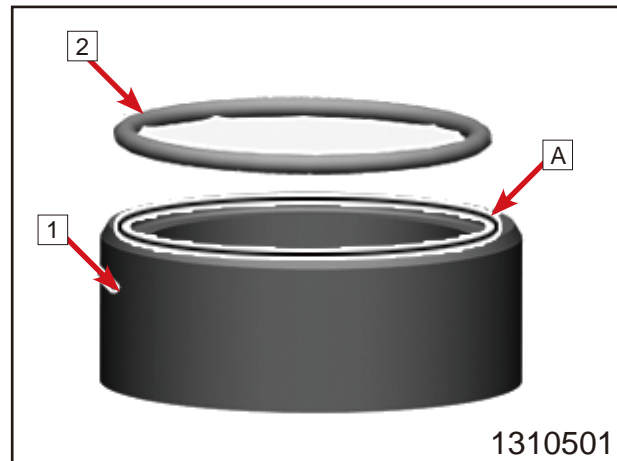

Grease the radial shaft seal ring.

Long-life grease
------------------

Push spacer (1) with the O-ring onto the countershaft with a twisting motion.

The recess with the O-ring faces inward.

The radial shaft seal ring rests against the spacer along its entire circumference.

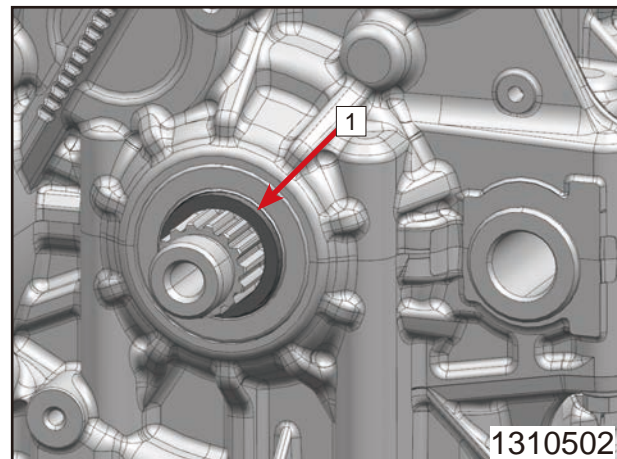

## 13.5.26 Installing the Gear Position Sensor

Position gear position sensor (1).

Mount and tighten screws (2).

### Guideline

Screw, gear position sensor
-----------------------------

M5
----

6 N•m (4.4 lbf ft)
--------------------

243 Thread locker
-------------------

Secure the cable with a cable tie.

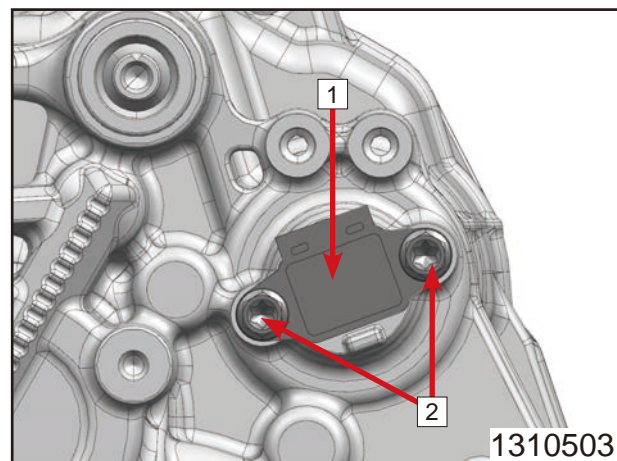

## 13.5.27 Installing the Shift Shaft Sensor

Mount pin (1).

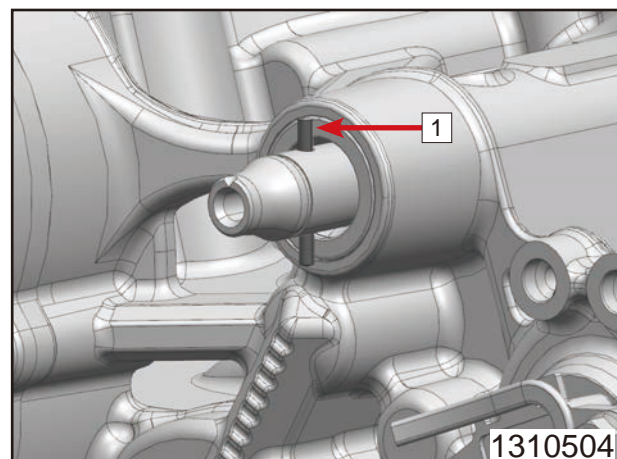

- Mount magnetic holder (2).
- Mount locating washer (3).
- Mount washer (4).
- Mount lock ring (5).

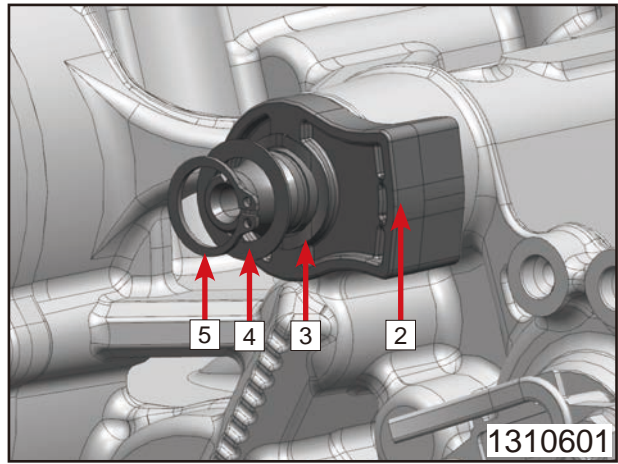

- Position the shift shaft sensor (6).
  - Mount and tighten screws (7).
- Guideline

Screw, shift shaft sensor
M5
6 N•m
243 Thread locker

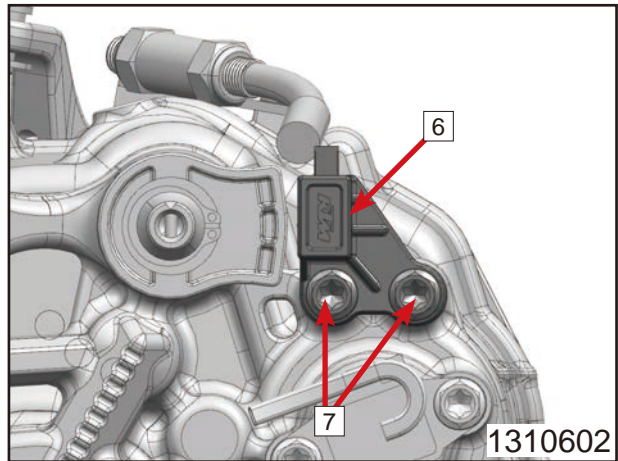

### 13.5.28 Installing the Valve Cover

Clean and degrease the valve cover seal.  
Apply a thin layer of sealing compound to area (A) and (B).

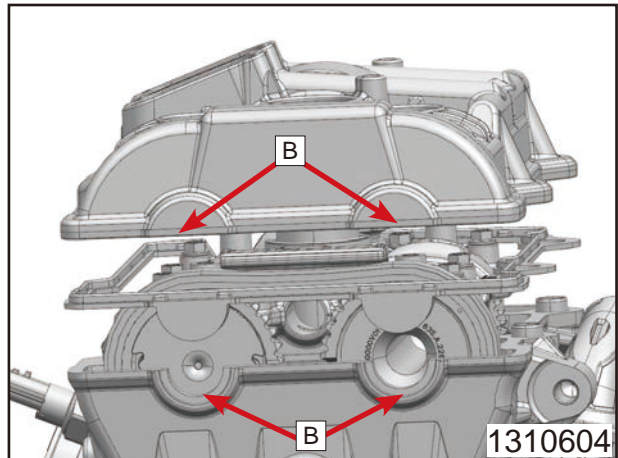
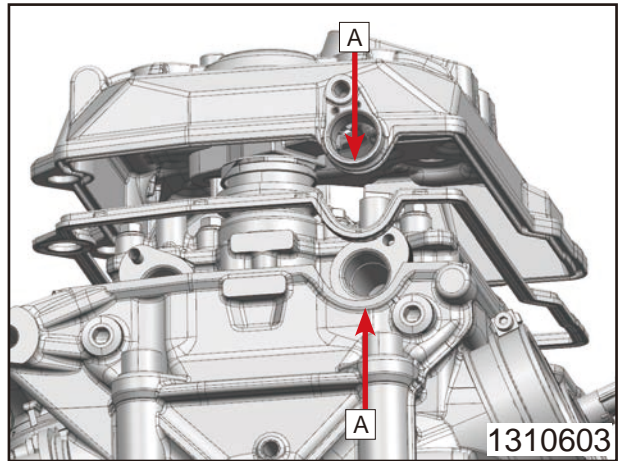

## 13 Engine

Position the valve cover with the valve cover seal.  
Mount and tighten screws (1) with the gaskets.

### Guideline

Screw, valve cover
M6
10 N•m

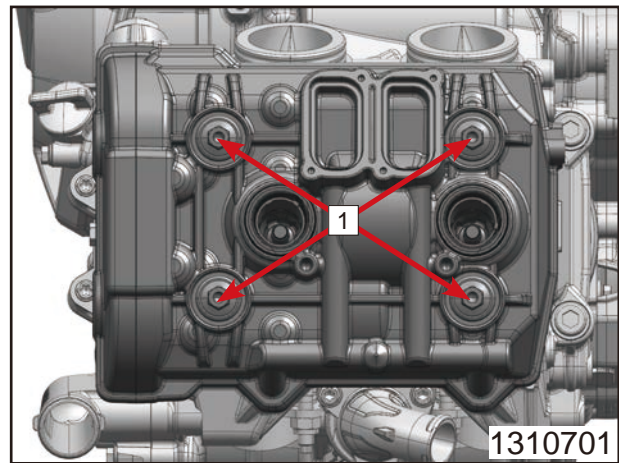

Grease O-ring (2).

Long-life grease
------------------

Position the bleeder flange in the valve cover.

Mount and tighten screw (3) with retaining bracket.

### Guideline

Screw, bleeder flange
M6x12
8 N•m
243 Thread locker

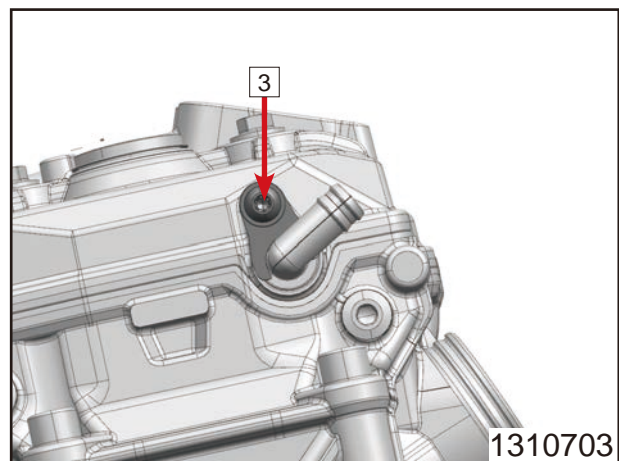
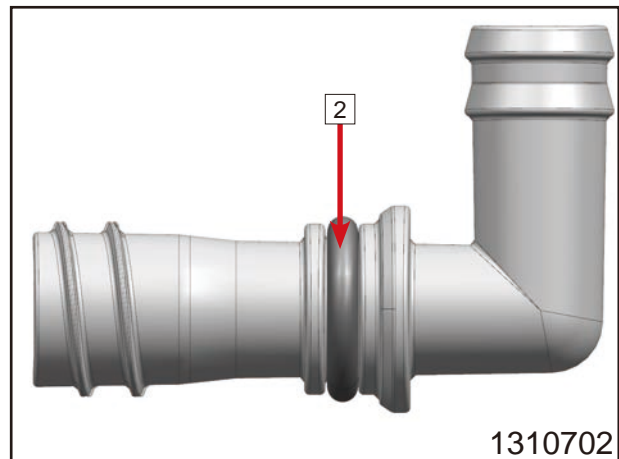

Mount ignition coils (4).  
Mount and tighten screws (5).

### Guideline

Screw, ignition coil
M6
8 N•m

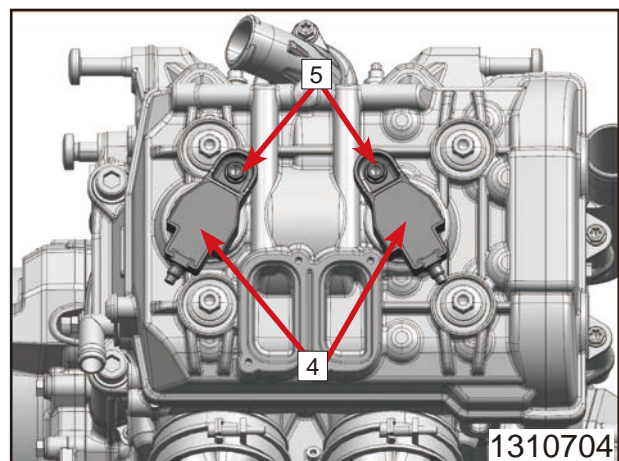

© CFMOTO Powersports, Inc. This manual is subject to all applicable copyright laws. Reproduction or duplication in any form, whole or in part, is strictly prohibited.

## 13.5.29 Installing the Starter Motor

Grease the O-ring and mount the starter motor.

Long-life grease
------------------

Mount and tighten screw (1).

### Guideline

Screw, starter motor
----------------------

M6
----

10 N•m
--------

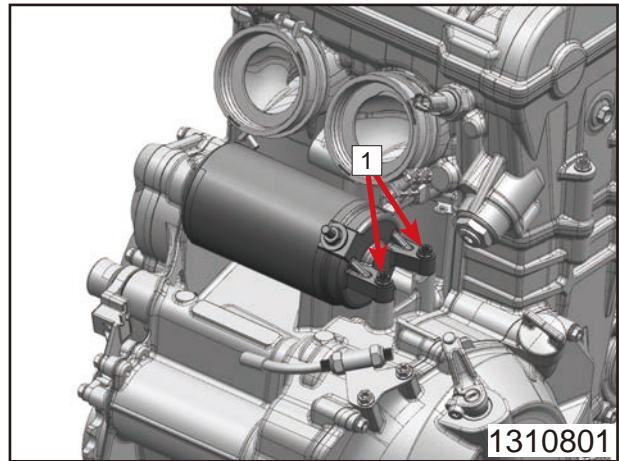

1310801

## 13.5.30 Installing the Oil Filter

Tilt the motorcycle to one side and fill the oil filter housing to about  $\frac{1}{3}$  full with engine oil.

Engine oil (SAE 10W/50)
-------------------------

Mount oil filter (1).

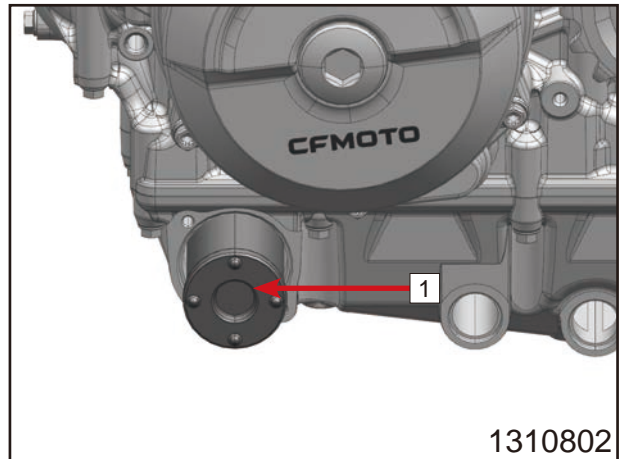

1310802

Oil the O-ring of oil filter cover (2). Mount the oil filter cover.

Mount and tighten screws (3).

### Guideline

Screw, oil filter cover
-------------------------

M5
----

6 N•m
-------

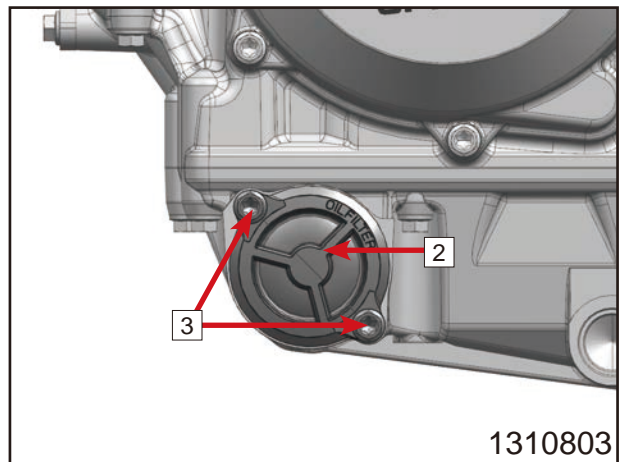

1310803

## 13.5.31 Installing the Oil Drain Plug

Mount the new O-rings.

Mount and tighten the oil drain plugs (1) with the magnet, O-rings, and oil screen.

### Guideline

Plug, oil screen
------------------

M20x1.5
---------

20 N•m
--------

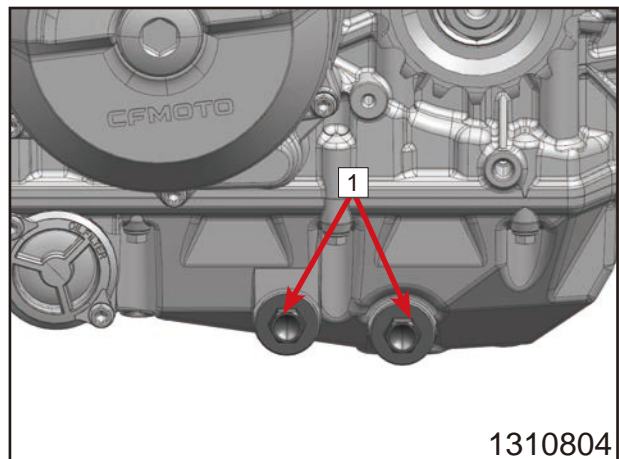

1310804

# 14 Handlebar and Triple Clamps

---

<b>14.1 Handlebar .....</b>	<b>2</b>
14.1.1 LH Handlebar Switch.....	2
14.1.2 RH Handlebar Switch .....	3
<b>14.2 Throttle Grip.....</b>	<b>3</b>
<b>14.3 Handlebar Inspection .....</b>	<b>3</b>
14.3.1 Handlebar Interference Inspection .....	4
<b>14.4 Triple Clamps and Front Forks.....</b>	<b>5</b>

© CFMOTO Powersports, Inc. This manual is subject to all applicable copyright laws. Reproduction or duplication in any form, whole or in part, is strictly prohibited.

## 14.1 Handlebar

Handlebar removal refers to 12.1.

### 14.1.1 LH Handlebar Switch

#### Removal

Remove screw.

Remove fog light switch.

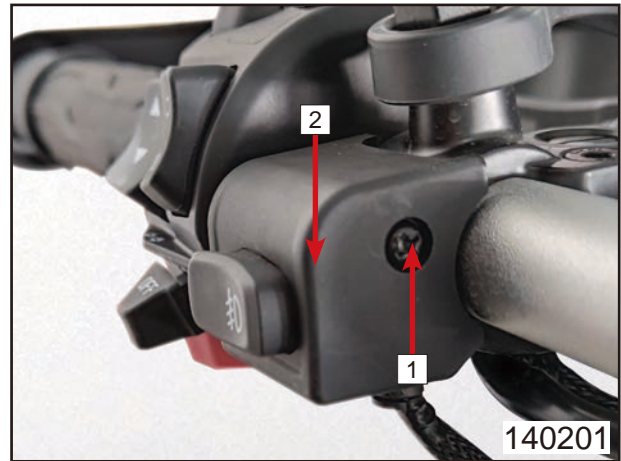

Remove inner hex bolt [3].

Remove clutch lever [4].

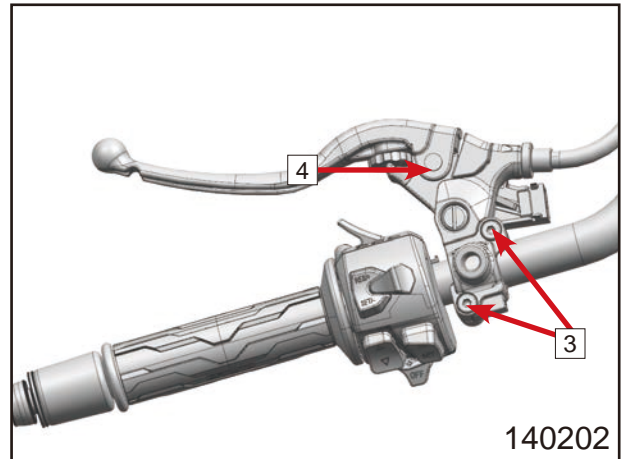

Remove screws [5].

Remove LH handlebar switch.

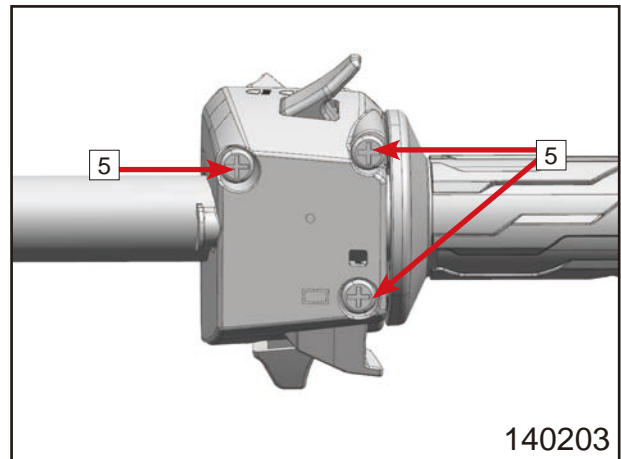

# 14 Handlebar and Triple Clamps

## Installation

Align LH lower housing position pin with holes on LH handlebar switch.  
Install LH upper cover.  
Install three screws.

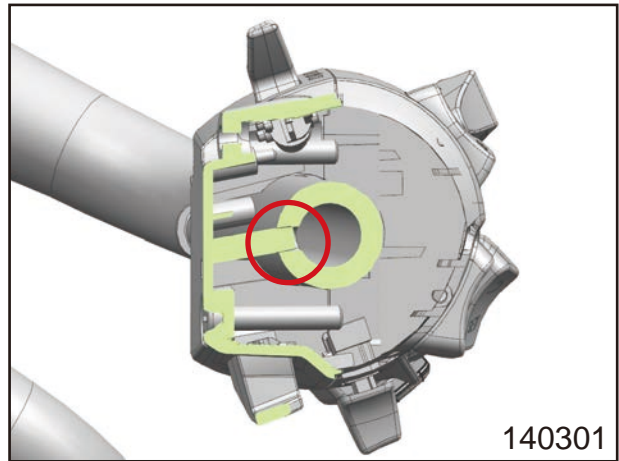

## 14.1.2 RH Handlebar Switch

### Removal

Remove bolt [1].  
Separate RH handlebar switch lower cover [2] and upper cover [3].

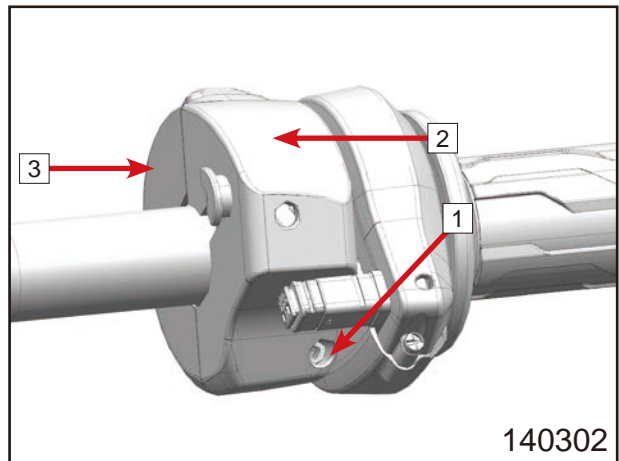

### Installation

Reverse the removal procedures for installation.

## 14.2 Throttle Grip

E-throttle refers to Electrical System.

## 14.3 Handlebar Inspection

### Clutch Lever Free Play

Check clutch lever smoothness.  
Turn handlebar towards the left to the end.  
Slowly apply the clutch lever until the resistance is evident.  
Measure the free play at location A: 0.079 in (2 mm) is appropriate.

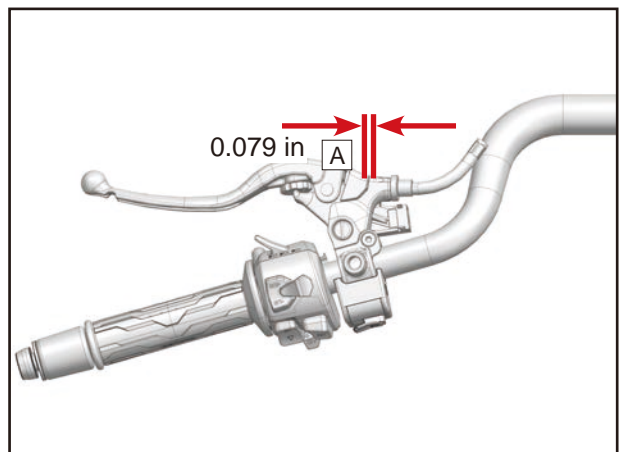

© CFMOTO Powersports, Inc. This manual is subject to all applicable copyright laws. Reproduction or duplication in any form, whole or in part, is strictly prohibited.

## ⚠ WARNING

Inadequate free play for the clutch lever can strain the clutch cable and affect clutch engagement, causing slippage and excessive wear.

**Inspect the free play every time before running the engine.**

Set the free play as stipulated when necessary.

### Clutch Lever Free Play Fine Adjustment

Turn handlebar towards the left to the end.

Loosen lock nut **1** and rotate the adjusting nut **2** for adjustment.

Once the desired free play is achieved, tighten the lock nut **1**.

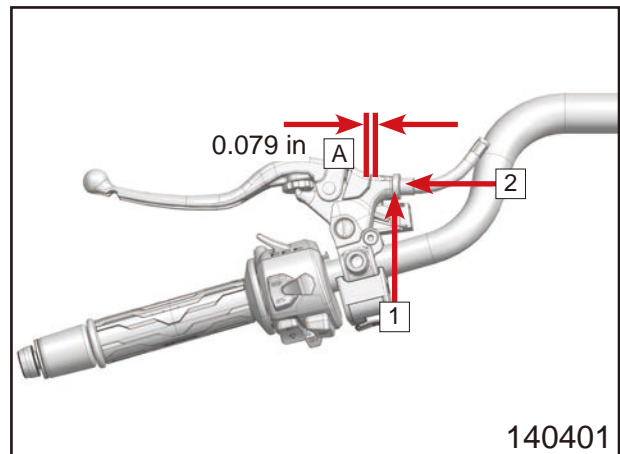

Major adjustment: Loosen lock nut **4** and rotate the adjusting nut **3** for adjustment. At last, tighten the lock nut **4**.

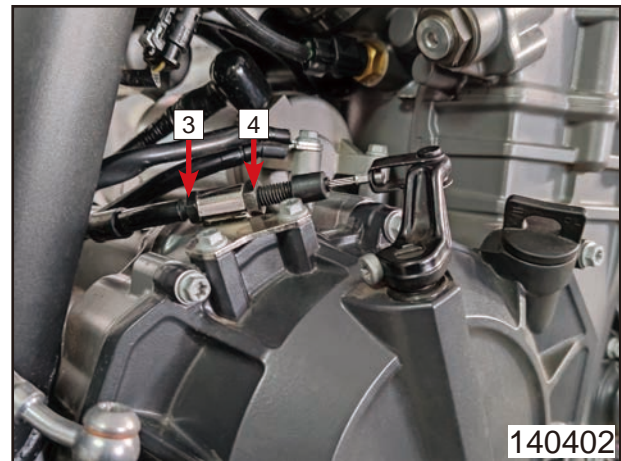

### 14.3.1 Handlebar Interference Inspection

Turn the handlebar left and right to check whether cables interfere front wheel.

When the turning angle is the maximum, check if the handlebar interferes the fuel tank.

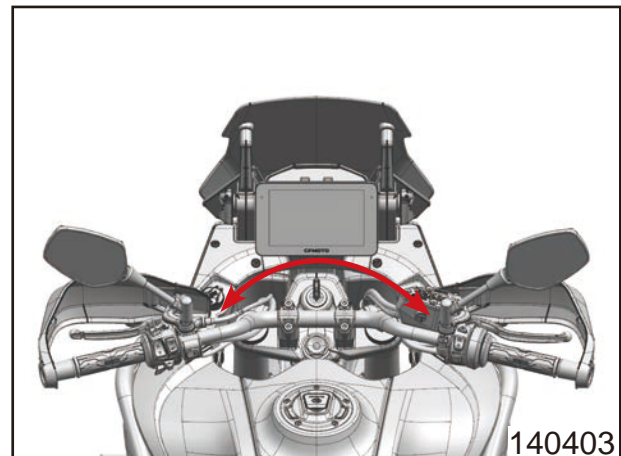

# 14 Handlebar and Triple Clamps

## 14.4 Triple Clamps and Front Forks

### Removal

Remove two inner hex bolts [1].

Remove handlebar seat [2].

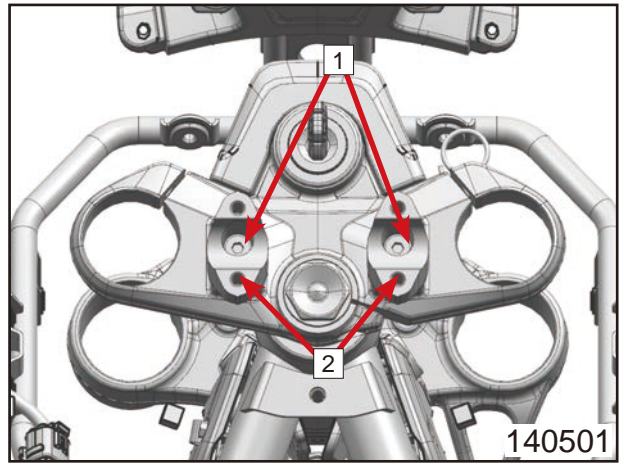

Remove inner hex bolts [3].

Remove upper triple clamp screw and washer [4].

Remove upper triple clamp [5].

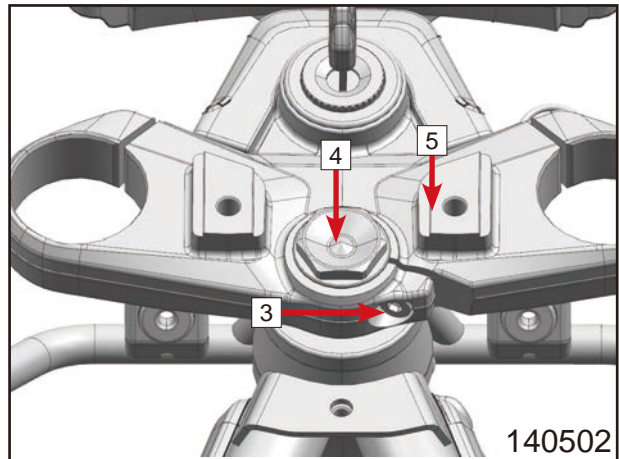

Remove dust-proof cover and washer kit [4].

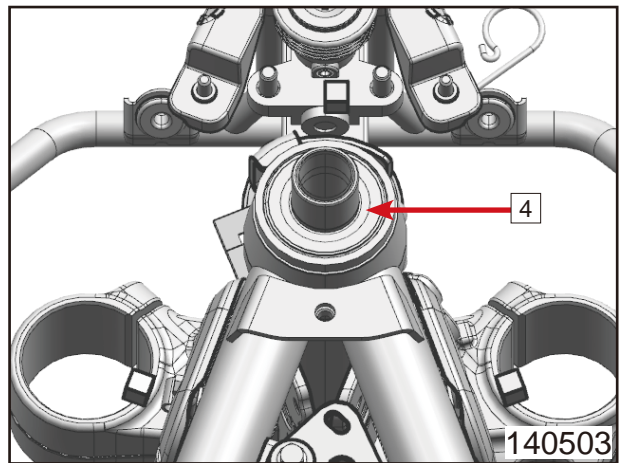

Remove inner hex bolts. Separate steering damper and lower triple clamp (OFF-ROAD).

Remove lower triple clamp [5].

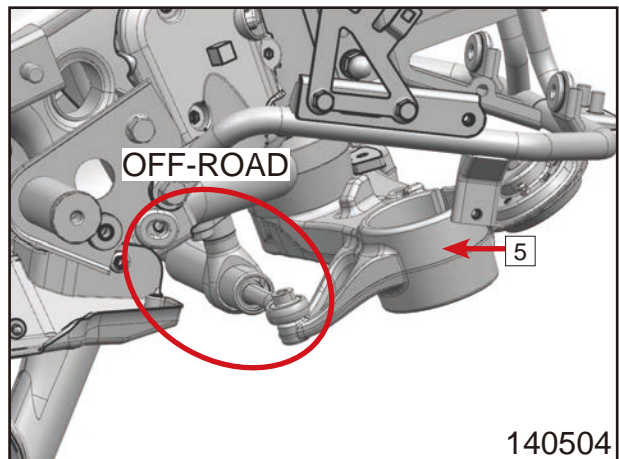

© CFMOTO Powersports, Inc. This manual is subject to all applicable copyright laws. Reproduction or duplication in any form, whole or in part, is strictly prohibited.

# CFMOTO

## Inspection

Inspect steel ball assy 1 for wear or missing. Replace if any defect is found.  
Inspect bearing cage for cracks or abnormal wear. Replace if any defect is found.

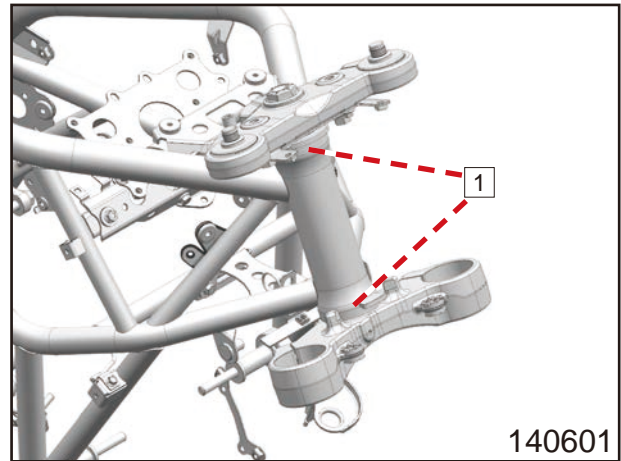

## Installation

Reverse the removal procedures for installation.

Steering column nut torque: 25 N•m

Upper triple clamp lock screw torque: 20 N•m

**NOTE: Apply enough grease to bearing cage during installation and replacement.**